

Aircraft Interior Noise Isolation

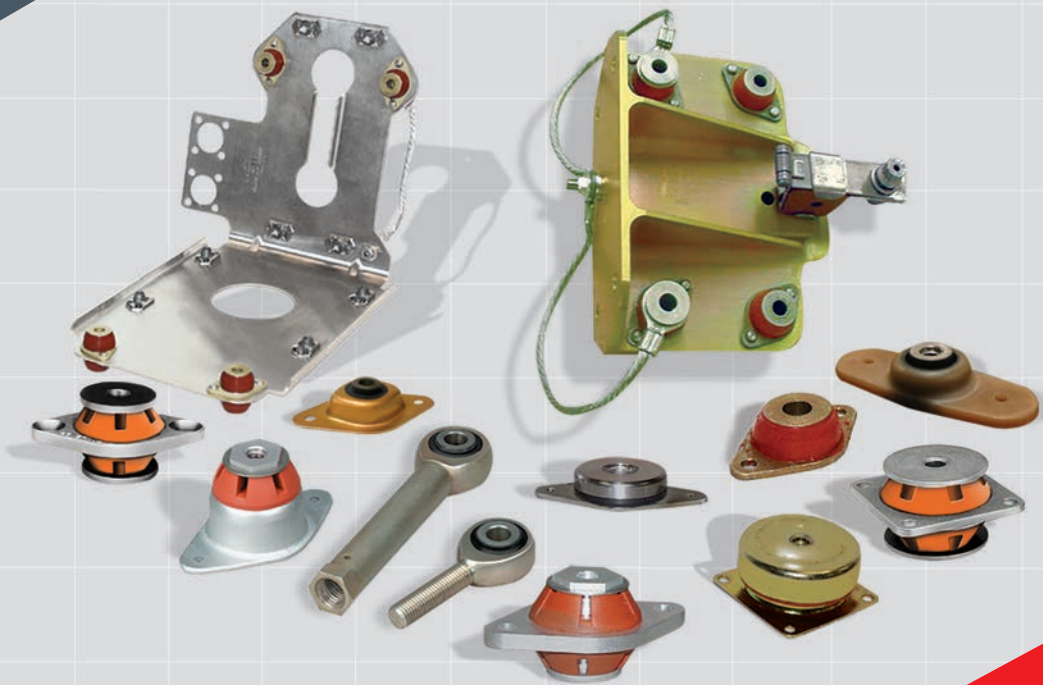

ENIDINE

Elastomeric Panel Isolators

Enidine is your partner for standard and custom elastomeric isolation systems for aircraft interior noise control. Successful isolation systems account for the properties for the aircraft systems to which they attach. We have a proven engineering approach for high frequency noise attenuation, and the engineers, materials, and test capabilities that allow us to develop and qualify your system.

As experts in the field of structure borne noise for aircraft interiors, Enidine provides the following services:

Prediction of In-situ Attenuation of Isolator –

Classical mass-spring-damper approach cannot be used to predict high frequency noise attenuation. Enidine uses the four pole method to capture the dynamic performance of the isolator, and the attaching structure.

Elastomeric material development –

Proprietary compounds are formulated based on the requirement for the isolator. Desired noise attenuation, temperature extremes, loads, and fatigue life are important criteria when selecting and developing compounds for aircraft interiors.

Installation Requirements –

Installation requirements are extremely important. These isolators provide mechanical torque resistance to ensure that the elastomer does not tear during installation. Enidine has also developed a number of isolators mated with plastic brackets to provide low weight cost effective customer solutions

Fatigue life –

Enidine understands the requirements to provide an isolation system with long life. Fatigue life for elastomeric isolators is directly related to frequency and amplitude. Enidine has the expertise to design and test your isolation systems to ensure longevity.

Temperature Extremes –

The dynamic performance of the isolator is very dependent on the temperature at which it performs. Enidine designs and tests the isolator for these specific temperatures.

Static and Ultimate Loads –

Enidine's isolators are designed to provide optimal performance at the specified static loads. The isolators also incorporate a fail safe mechanism to ensure the ability of the isolator to resist ultimate loads.

Custom solutions –

Enidine has a dedicated group of engineers, supported by the required analytical, design, manufacturing, and testing resources focused on the design of aircraft interior isolators. We offer traditional metallic isolators, and isolators using plastic materials. As a leader in this field, Enidine can also partner with you on the specification development for these isolators.

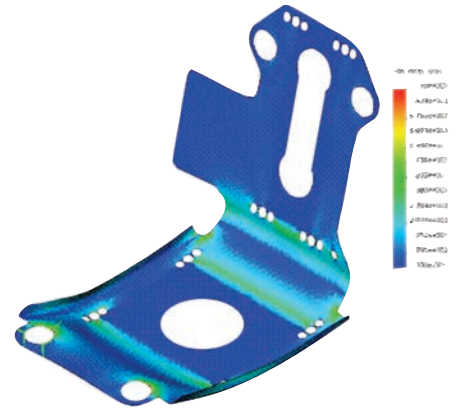



Elastomeric Panel Isolator Products

The desire to control aircraft interior noise for enhanced passenger/crew comfort has presented significant challenges for aircraft designers. Industry standard mounts often fail to take advantage of improved features and materials to optimize noise attenuation. Noise testing based on the 4-Pole Test method demonstrates that significant gains in noise isolation are available without sacrificing size, weight or load capacity.

Product Selection

Enidine Incorporated now offers a line of isolators to provide optimized noise/vibration attenuation for a variety of aircraft interior applications. These isolators provide significantly better noise attenuation compared to industry “standard” mounts.

Designed to accommodate a range of mounting configurations and load conditions, Enidine Panel Isolators can be used for sidewall and ceiling panels, as well as for mounting IFE and other equipment.

Features and Benefits

- Exceptional Noise Attenuation Performance
- Fail Safe Low-Profile Design
- Improved Composite Frame Noise Attenuation Performance
- Interchangeable with Existing Isolators
- Multiple Elastomer Stiffnesses Available in the Same Envelope Size

Typical Applications

- Sidewall Panels
- Dado Panels
- Ceiling Panels
- Interior Trim / Door Panels

Technical Data

Models:
E111528
E111573



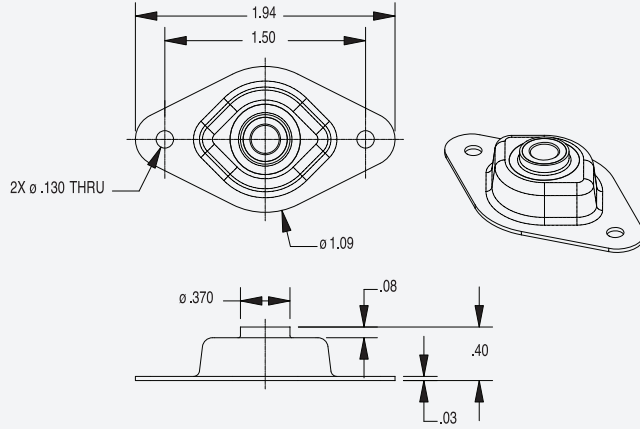

Materials:
Aluminum Alloy
Cres
Steel

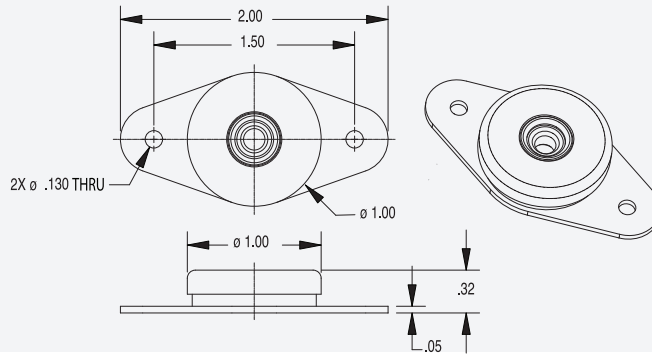

Models:
E111588
E111589
E111590

Materials:
Cres



Product	Part Number	Thru Hole	Rated Load (lbs.)	Ultimate Load (lbs.)	Product	Part Number	Thru Hole	Rated Load (lbs.)	Ultimate Load (lbs.)
	E111618	#10-32 UNJF-3B	4	100		E111573	#10-32 UNJF-3B Self Locking	9	200
	E111619	#10-32 UNJF-3B	8	200		E111588	#10-32 UNJF-3B Self Locking	25	800
	EE11746	#10-32 UNJF-3B Self Locking	8	100		E111589	#10-32 UNJF-3B Self Locking	75	800
	E111528	.290 Thru	9	200		E111590	#10-32 UNJF-3B Self Locking	100	800

Model:
E111618

Materials:
Aluminum Alloy
Cres

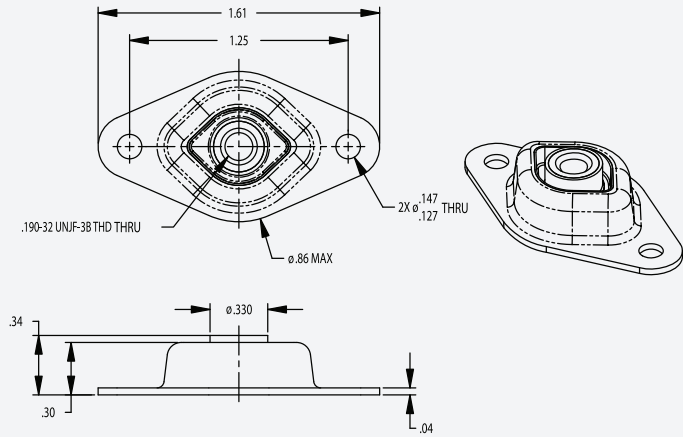

Model:
E111619

Materials:
Aluminum Alloy
Cres

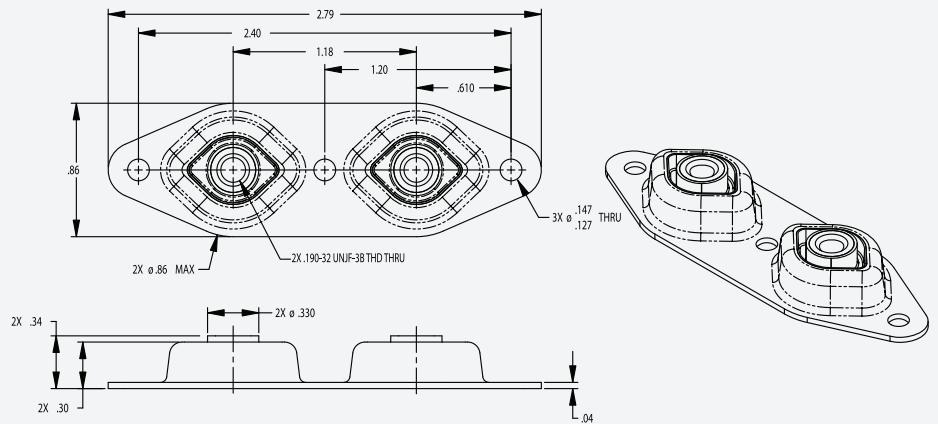

PART NUMBER	MTG HOLE ϕ ("A" DIM)
EE11746125	.125/.131
EE11746156	.156/.162
EE11746190	.190/.196
EE11746219	.219/.225
EE11746250	.250/.256

Model:
EE11746

Materials:
Ultem
Cres

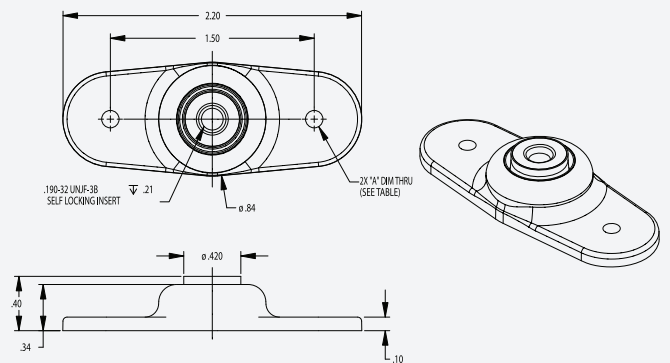

Custom Solutions

Enidine offers a full range of custom solutions, including both traditional metal and plastic housings. Please contact Enidine to discuss these solutions.

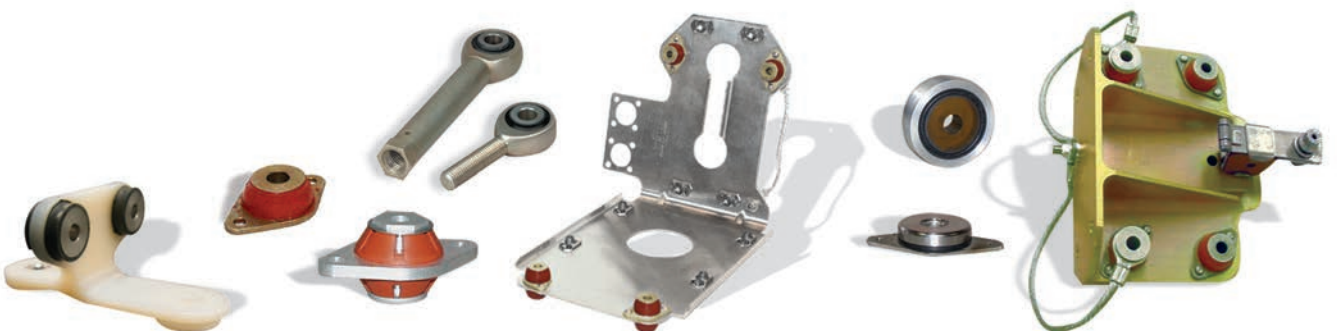

Enidine

7 Centre Drive
Orchard Park, New York 14127 • USA
Phone: 716-662-1900
Fax: 716-667-1385
Email: aviationsales@enidine.com
www.enidine.com

An ITT Company

AVI606R4 10/20