

MODULAR WINCH UNITS

6MBA for flow 120-650 lpm

Winch solution for fixed pumps

- Pipe mounted model
- Compact design
- By-pass compensator system for load independent control of hydraulic motor
- Load control valve of spool design
- Actuations
 - Manual
 - Hydraulic remote
 - Combination of those above
- Options for
 - Brake release valve
 - Remote operated pressure relief A - T/B for tension control
- Two speed selector valve
- Up to 5 NG6 flanges for operation of external functions
- Prepared to be fitted directly on hydraulic motor by use of an intermediate adapter plate

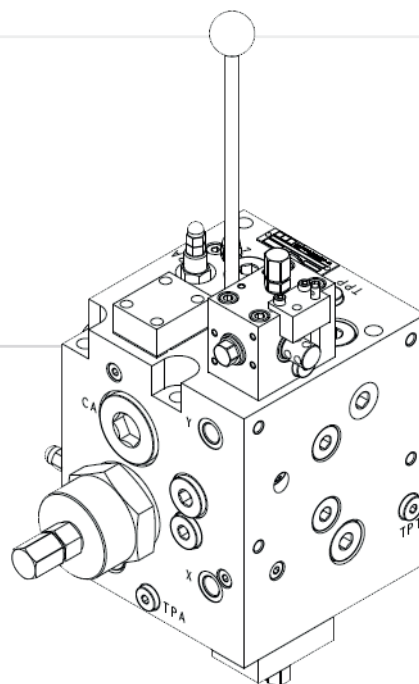

DESCRIPTION	DATA	
Flow ranges	320	320 l/min
	650	650 l/min
Weight	320	56 kg
	650	110 kg
Max pressure	P, A, B	350 bar
	T	207 bar
	D	10 bar
Pilot pressure	5-20 bar	
Test pressure	420 bar	
Fluid temperature range	-20°C to +70°C	
Ambient temperature range	-20°C to +50°C	

