

Newdeal REGULATOR



Highly reliable, heavy-duty piston-operated regulator.

- Stability of the set pressure as the upstream pressure varies
- Standard overpressure blowoff valve
- Can be fixed to the wall using the holes in the sides of the body.



TECHNICAL DATA		REG ND 1/4"	REG ND 3/8"	REG ND 1/2"	REG ND 3/4"	REG ND 1"
Threaded port		1/4"	3/8"	1/2"	3/4"	1"
Setting range	bar	0 to 4 - 0 to 8 - 0 to 12	0 to 4 - 0 to 8 - 0 to 12		0 to 4 - 0 to 8 - 0 to 12	
Max. inlet pressure	MPa	1.8	1.8		1.8	
	bar	18	18		18	
Flow rate at 6.3 bar (0.63 MPa to 91 psi) ΔP 0.5 bar (0.05 MPa to 7 psi)	Nl/min	200	1100		2500	
	scfm	7	39		89	
Flow rate at 6.3 bar (0.63 MPa to 91 psi) ΔP 1 bar (0.1 MPa to 14 psi)	Nl/min	650	2500		4500	
	scfm	23	89		160	
Max temperature at 1 MPa; 10 bar; 145 psi	°C	50	50		50	
	°F	122	122		122	
Weight	kg	0.3	0.8		1.5	
Wall fixing screws		M4 x 40	M4 x 55		M6 x 75	
Gauge port		1/8"	1/8"		1/4"	
Mounting position		In any position				
Fluid		Filtered, lubricated or unlubricated compressed air. Lubrication, if used, must be continuous.				
Note on use		The regulator pressure must always be set upwards.				
		For increased sensitivity, use a pressure regulator with a rated pressure as close as possible to the required value.				
		Do not take off air from gauge ports.				

COMPONENTS

- ① Zamak body
- ② Technopolymer bell
- ③ Technopolymer knob
- ④ Technopolymer piston rod
- ⑤ Technopolymer plug
- ⑥ OT58 brass adjusting screw
- ⑦ OT58 brass nut
- ⑧ Ring nut : technopolymer (ND 1/4-3/8-1/2) brass (ND 3/4-1)
- ⑨ OT brass rod
- ⑩ Valve with NBR vulcanized gasket
- ⑪ NBR lip seal
- ⑫ NBR relieving seal
- ⑬ Steel adjusting spring
- ⑭ Steel valve compression spring
- ⑮ NBR gaskets

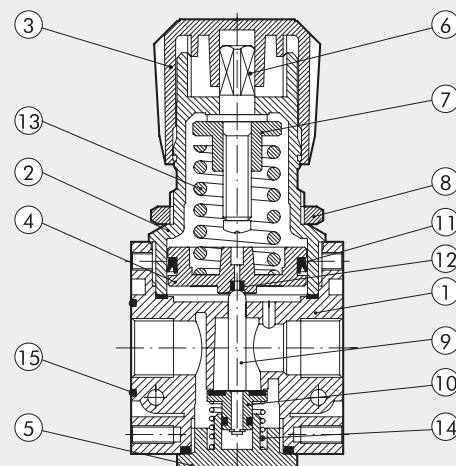

FLOW CHARTS

REG 1/4

$P_m = 0.7 \text{ MPa} - 7 \text{ bar} - 100 \text{ psi}$
Inlet pressure

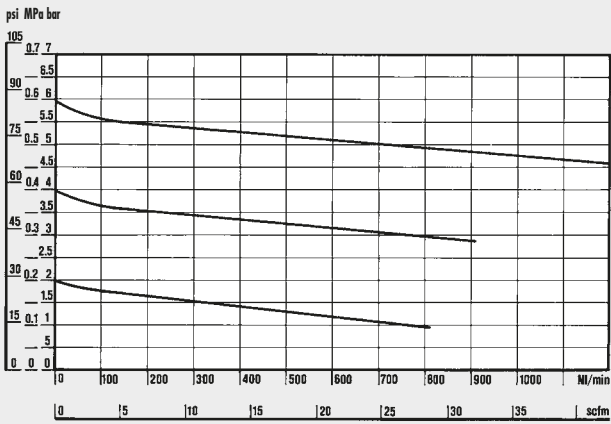

REG 3/8 - 1/2

$P_m = 0.7 \text{ MPa} - 7 \text{ bar} - 100 \text{ psi}$
Inlet pressure

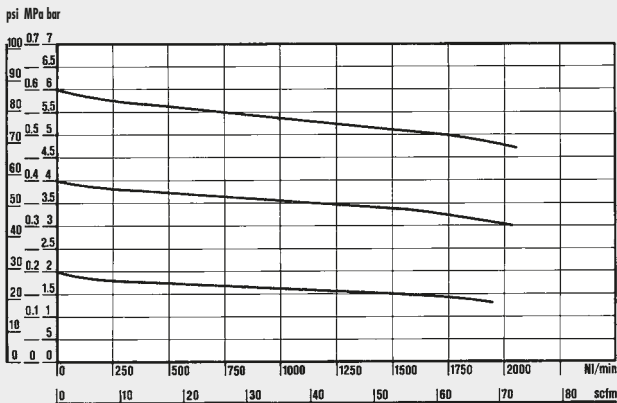

Department of Mechanics



Turin Polytechnic

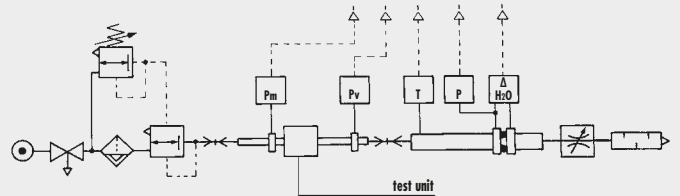

• Flow tests carried out at the Department of Mechanics, Turin Polytechnic, using the computerized test bench following CETOP RP50R recommendations (ISO DIS 6358-2-approved) with ISO 5167 diaphragm gauge.

REG 3/4 - 1"

$P_m = 0.7 \text{ MPa} - 7 \text{ bar} - 100 \text{ psi}$
Inlet pressure

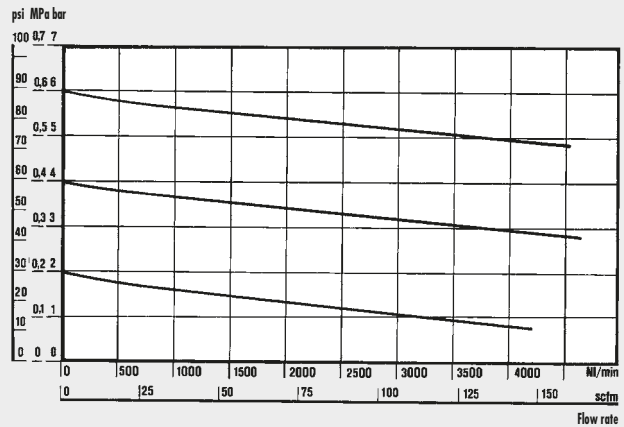

UNITS

New decl REGULATOR

DIMENSIONS

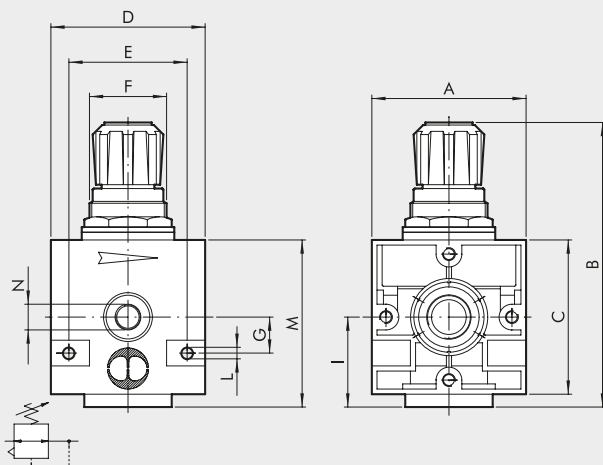

	REG ND 1/4"	REG ND 3/8"	REG ND 1/2"	REG ND 3/4"	REG ND 1"
Threaded port	1/4"	3/8"	1/2"	3/4"	1"
A	42	60		80	
B	94	130		184	
C	42	60		80	
D	42	60		80	
E	32	46		66	
F	30 x 1.5	38 x 2		55 x 2	
G	10	14		22	
I	25	35		47	
L	Hole for M4 screws	Hole for M4 screws		Hole for M6 screws	
M	49	70		94	
N (pressure gauge port)	1/8"	1/8"		1/4"	

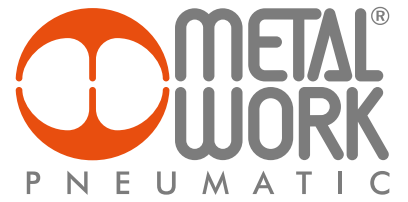

SYNOPTIC, SIZES AND VERSIONS

REG ELEMENT	1/4 THREADED PORT	04 SETTING RANGE
REG	1/4 3/8 1/2 3/4 1	04 = 0 to 4 bar 08 = 0 to 8 bar 012 = 0 to 12 bar

ORDERING CODES

Code	Description
New deal	REGULATOR 1/4"
1202001	REG 1/4 04
1202002	REG 1/4 08
1202003	REG 1/4 012
1202004	REG 1/4 02
New deal	REGULATOR 3/8"
1302001	REG 3/8 04
1302002	REG 3/8 08
1302003	REG 3/8 012
New deal	REGULATOR 1/2"
1402001	REG 1/2 04
1402002	REG 1/2 08
1402003	REG 1/2 012
New deal	REGULATOR 3/4"
1502001	REG 3/4 04
1502002	REG 3/4 08
1502003	REG 3/4 012
New deal	REGULATOR 1"
1602001	REG 1 04
1602002	REG 1 08
1602003	REG 1 012

NOTES