

Data Sheet

Itemnumber....: 5540901409

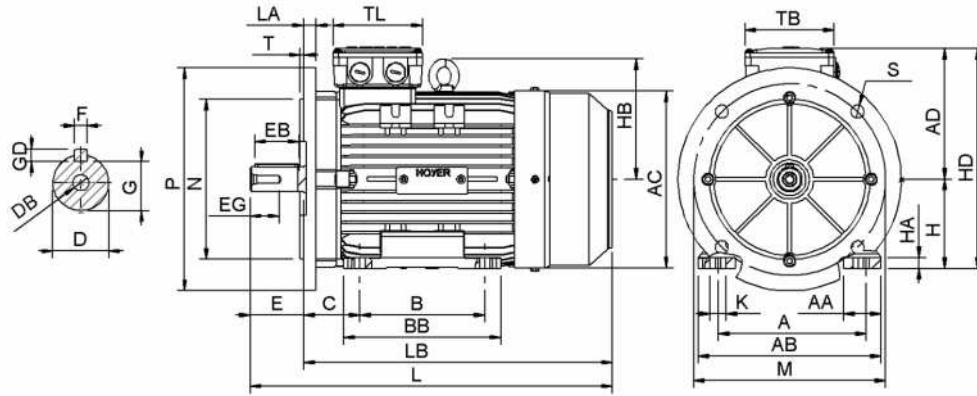

A = 140	AC = 175	BB = 155	DB = M8	EG = 24	GD = 7	HD = 222	LA = 10	M = 165	S = 4-Ø12	TL = 100
AA = 35	AD = 132	C = 56	E = 50	F = 8	H = 90	K = 4	LB = 312	N = 130	T = 3,50	
AB = 177	B = 125	D = 24	EB = 40	G = 20	HA = 13	L = 362	LE = 345	P = 200	TB = 100	

Version

Type.....: HMA3 90L-4
 Design.....: Induction motor
 Standard series.....: IEC 60034
 Phase / Voltage range.....: 3~ / Low

Electrical design

Efficiency.....: IE3
 Pole.....: 4
 Power at 50 Hz (kW).....: 1,50
 Hz.....: 50
 Voltage.....: 230VD/400VY
 Winding voltage.....: 230VD/400VY 50 Hz
 Power output (kW).....: 1,50
 Duty.....: S1
 Insulation class.....: F
 Temperature rise.....: B

Mechanical design

Frame size.....: 90
 Mounting.....: B35
 Rain cap.....: No
 Protection class.....: IP55
 Cooling method.....: IC411/TEFC
 External grounding.....: Yes
 Drain hole.....: Yes
 Frame material.....: Aluminium
 Material approval.....: None
 Shaft.....: IEC standard
 Key.....: Closed key
 Balancing.....: Half key balancing
 Vibration class.....: Grade-A
 Weight (kg).....: 18,5

Bearing

DE Bearing.....: 6205-ZZ/C3
 NDE Bearing.....: 6205-ZZ/C3
 Fixed bearing.....: DE

Terminal box

Tbox position.....: Top
 Cable entry direction.....: Right (from DE)
 Cable entry
 Main.....: 2 x M20x1,5
 Plastic blindcaps
 Accessory.....: NA
 Connection type.....: Star (Y)
 Terminal board thread.....: 6-M4

Environment condition

Ambient temp. min. (°C)..: -20
 Ambient temp. max. (°C)..: 40
 Altitude (mtr up to).....: 1000

Test values

Rotor inertia (kgm²).....: 0,0049
 Noise level (dB(A)).....: 54
 No load current (A).....: 2,20
 Winding resist. (ohm).....: 2,12
 Starting time (sec.).....: 0,03
 Temp. rise winding (K).....: 44
 Temp. rise surface (K).....: 36

Motor protection

Thermal protection main....: PTC 3x 155 dgr
 Thermal protection second..: None
 Space heater.....: None
 Temperature detector.....: No
 SPM.....: No
 IR wire.....: No
 Tropical insulation.....: No

Explosion protection

According to.....: None
 Type of protection.....: None

General

Direction of rotation.....: CW
 Painting.....: RAL 9005 Gloss 10
 Nameplate.....: Multivoltage
 Special packing.....: No
 Special requirements.....: No

Rated power (kW)	1,50	1,46	1,80	1,74
Frequency (Hz)	50	50	60	60
Voltage (V)	230 400	220 380	280 480	440
Connection	D Y	D Y	D Y	Y
Full load current (A)	6,00 3,45	6,15 3,55	6,00 3,45	3,55
Speed (rpm)	1450	1450	1730	1730
Power factor cos(phi)	0,74	0,75	0,74	0,77
Efficiency, 100/75/50 (%)	85,3/85,0/82,5	85,3/85,0/82,5	85,3/85,0/82,5	84,3/84,0/81,3
Ist/In	8,2	7,2	8,2	7,6
Full load torque (Nm)	9,85	9,55	9,85	9,55
Tst/Tn	2,9	2,7	2,9	2,5
Tmax /Tn	3	2,8	3	2,6
Duty	S1	S1	S1	S1
Ambient temp. (°C)	40	45	40	45