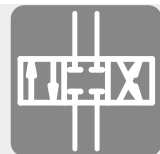


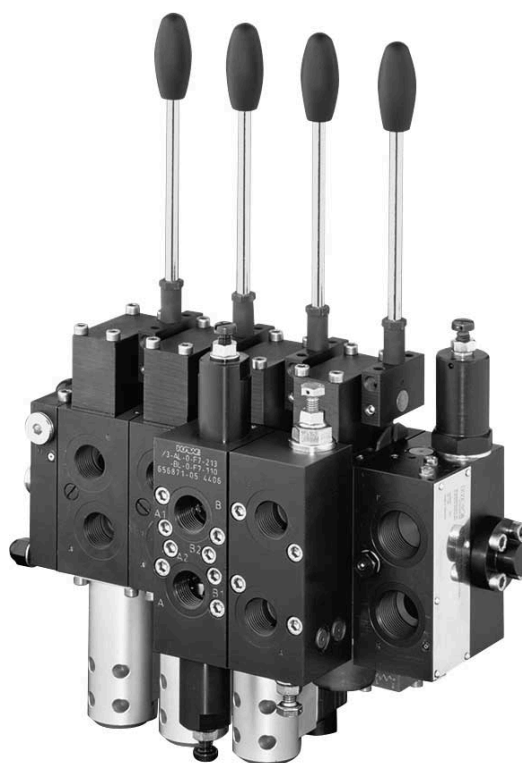
Proportional directional spool valves types PSL/PSV/PSM, size 3

Product documentation



Series connection

Operating pressure p_{\max} :	420 bar
Flow rate (pump) Q_{\max} :	200 lpm
Flow rate (consumer) $Q_{\max A/B}$:	120 lpm



© by HAWE Hydraulik SE.

The reproduction and distribution of this document as well as the use and communication of its contents to others without explicit authorisation is prohibited.

Offenders will be held liable for the payment of damages.

All rights reserved in the event of patent or utility model applications.

Brand names, product names and trademarks are not specifically indicated. In particular with regard to registered and protected names and trademarks, usage is subject to legal provisions.

HAWE Hydraulik respects these legal provisions in all cases.

Printing date / document generated on: 26.10.2020

Contents

1	Introductory description of proportional directional spool valves types PSL/PSV/PSM, size 3.....	4
1.1	Configuration example PSL 3.....	5
1.2	Configuration example PSL 3 together with PSL 5, PSL 2 and EDL 2.....	6
2	Available versions, main data.....	7
2.1	Order coding, overview.....	7
2.2	Connection block.....	9
2.3	Valve section.....	24
2.3.1	Directional valve section.....	27
2.3.2	Ancillary block.....	51
2.3.3	Intermediate plate.....	57
2.4	Series intermediate plate.....	61
2.5	Valve section with integrated load-holding valves.....	69
2.6	End plate.....	73
2.7	Solenoid voltage and solenoid version.....	76
3	Parameters.....	79
3.1	General and hydraulic.....	79
3.2	Characteristics.....	82
3.3	Electrical parameters.....	86
3.3.1	Electro-hydraulic actuation EI, EA, EH, EF etc. with standard solenoid.....	86
3.3.2	Electro-hydraulic actuation EI, EA, EH, EF etc. with solenoid for potentially explosive atmospheres.....	89
3.3.3	Switching position monitoring, displacement transducer.....	90
3.3.4	Switching position monitoring, displacement transducer for potentially explosive atmospheres.....	93
3.3.5	Electric LS relief or LS pressure limitation.....	94
3.3.6	Electric LS relief or LS pressure limitation for potentially explosive atmospheres.....	96
3.3.7	Additional valves.....	96
4	Dimensions.....	97
4.1	Connection block.....	97
4.2	Valve section.....	114
4.2.1	Directional valve section.....	114
4.2.2	Ancillary block.....	133
4.2.3	Intermediate plate.....	148
4.3	Series intermediate plate.....	154
4.4	Valve section with integrated load-holding valves.....	161
4.5	End plate.....	163
5	Assembly, operation and maintenance recommendations.....	168
5.1	Intended use.....	168
5.2	Assembly information.....	168
5.2.1	Attachment.....	168
5.2.2	Piping.....	168
5.2.3	Converting the connection block from PSL to PSV.....	169
5.2.4	Changing the valve spool.....	170
5.2.5	Seal kits.....	170
5.3	Operating instructions.....	171
5.4	Maintenance information.....	171

1 Introductory description of proportional directional spool valves types PSL/PSV/PSM, size 3

Proportional directional spool valves are a type of directional valve. They control the direction of movement and the velocity of individual or multiple hydraulic consumers actuated simultaneously. Control is independent of the load and continuous.

The proportional directional spool valve type PSL is suitable for constant pump systems and type PSV is for variable pump systems. The flow rates and load pressures for the individual consumers can be individually adjusted. The proportional directional spool valve type PSL and PSV can be adapted to various control tasks, e.g. for safety functions. All sizes can be combined with each other.

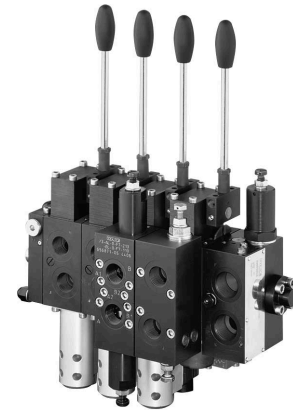
The proportional directional spool valve type PSL and PSV is used in mobile hydraulics, in particular in loading cranes, lifting platforms, municipal trucks, construction machines, drilling equipment and machines for forestry and agricultural purposes.

Features and benefits:

- Universally usable product for various flow rates and functions
- Extensive modular system with many variants and combination options
- Compact and lightweight design
- Robust and long-lived design for pressures up to 420 bar
- Highest energy efficiency thanks to low Δp and low-energy solutions

Intended applications:

- Loading cranes
- Lifting platforms
- Municipal trucks
- Construction machines
- Drilling equipment
- Machines for forestry and agricultural purposes

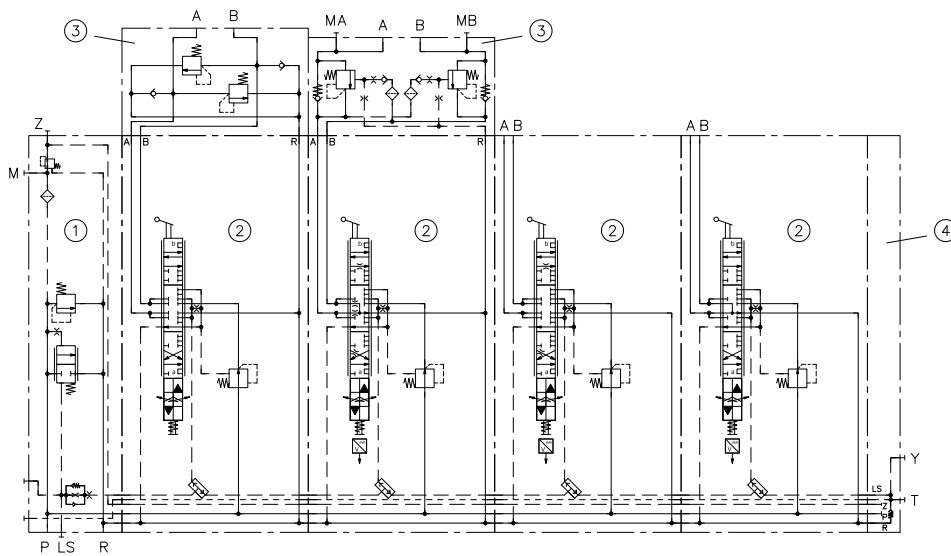
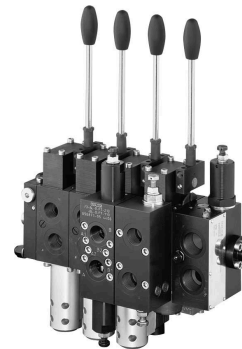


Proportional directional spool valve type PSL 3

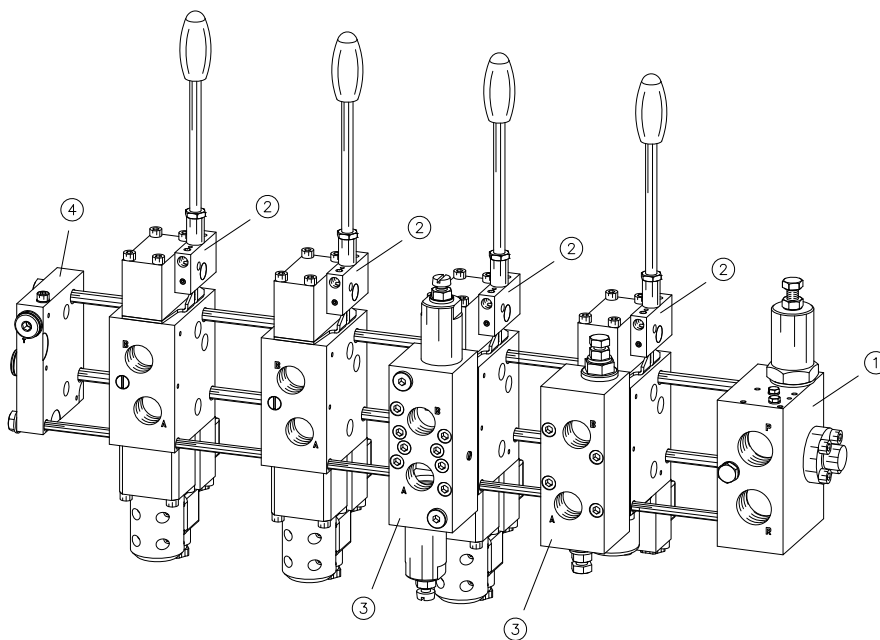
1.1 Configuration example PSL 3

PSL 41/420-3

- A2 L 80/63/EA/3 AN350 BN350
- A2 O 80/80/EAWA/3 AL-0-A 7/400-BL-0-B 7/400
- 32 J 63/40/EAWA
- 32 H 25/25/EAWA
- E 4 - G 24

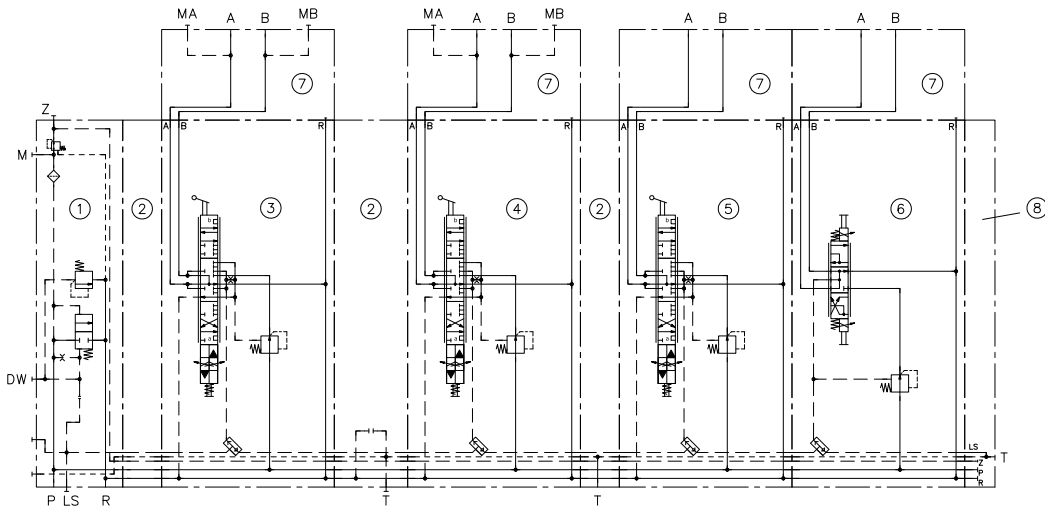


- 1 Connection block
- 2 Valve section
- 3 Ancillary block
- 4 End plate

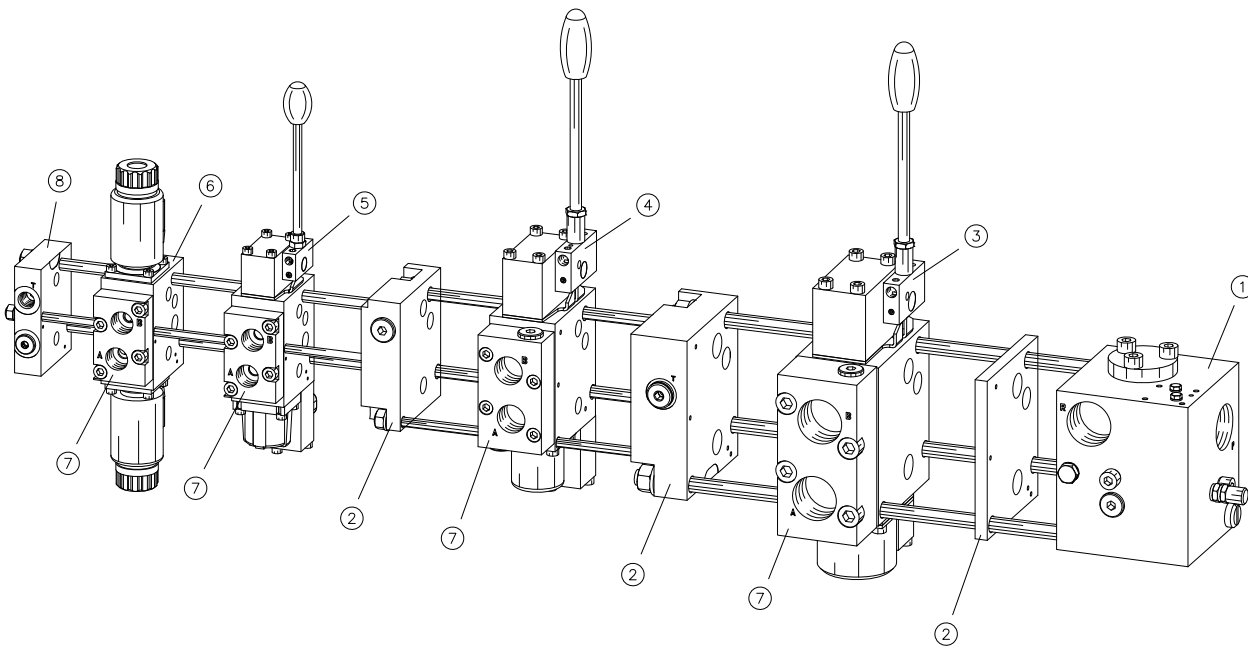


1.2 Configuration example PSL 3 together with PSL 5, PSL 2 and EDL 2

PSV 51/300-5
 - ZPL 55/9
 - A2 H 160/160/EA/5
 - ZPL 531
 - A2 H 80/80/EA/3
 - ZPL 32
 - A2 H 40/40/EA/2
 - DA2 H 40/40/EI/2
 - E 1-DT 24



- 1 PSL 5 connection block
- 2 Intermediate plate
- 3 PSL 5 valve section
- 4 PSL 3 valve section
- 5 PSL 2 valve section
- 6 EDL 2 valve section
- 7 Ancillary block
- 8 PSL 2 end plate

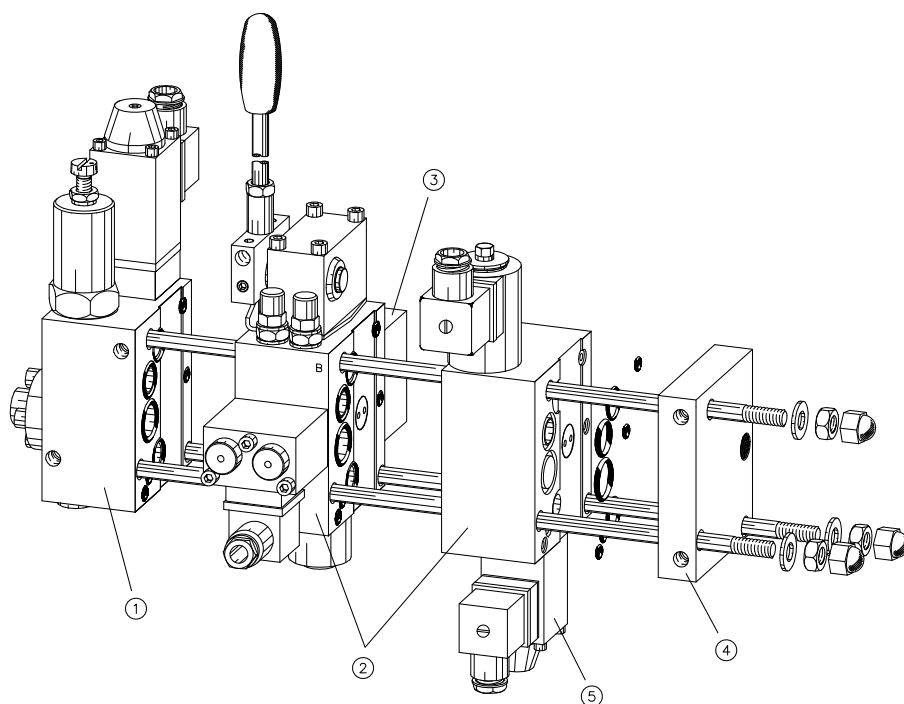


2 Available versions, main data

2.1 Order coding, overview

Order coding example:

PSL 31F/420-3	- A2 L 80/63 A350 B300 F 3/E0A	/3	- A1RR VPV	/5	- E 2	- G 24
						Solenoid voltage and solenoid version 2.7 "Solenoid voltage and solenoid version", Page 76
					End plate	2.6 "End plate", Page 73
					Ancillary block	2.3.2 "Ancillary block", Page 51
					Series intermediate plate	2.4 "Series intermediate plate", Page 61
					Ancillary block	2.3.2 "Ancillary block", Page 51
					Valve section	2.3 "Valve section", Page 24
					Connection block	2.2 "Connection block", Page 9



- 1 Connection block ([Chapter 2.2](#))
- 2 Valve section ([Chapter 2.3](#)),
Series intermediate plate ([Chapter 2.4](#)) or
valve section with integrated load-holding valves ([Chapter 2.5](#))
- 3 Ancillary block ([Chapter 2.3.2](#)) or intermediate plate ([Chapter 2.3.3](#))
- 4 End plate ([Chapter 2.6](#))
- 5 Solenoid voltage and solenoid version ([Chapter 2.7](#))

A single manifold can merge up to 12 size-3 valve sections.

This number can be increased by combining with a PSL 5 or PSL 2. When doing so, transition plates are employed and each size has its own tension rod.

Limits to the maximum possible number of valve sections result from:

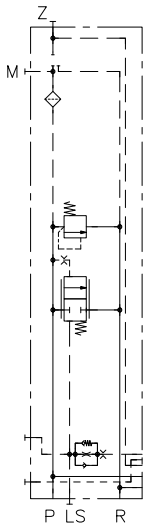
- a) tension rod strength
- b) internal control oil supply for the electro-hydraulic actuation
- c) the available control pressure difference for supply to the rear valve sections

2.2 Connection block

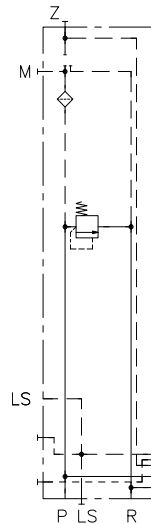
Connection blocks come in three basic variants:

- **PSL:** Connection block with integrated 3-way controller for use in open centre systems with constant pumps
- **PSV:** Connection block without 3-way controller for use in closed centre systems with variable pumps or for simultaneous supply of two or more manifolds from a shared constant pump
- **PSM:** Connection block capable of switching between open centre and closed centre

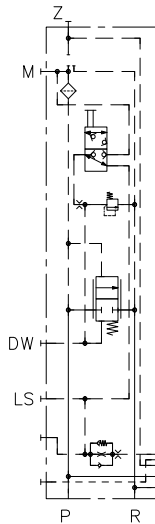
PSL



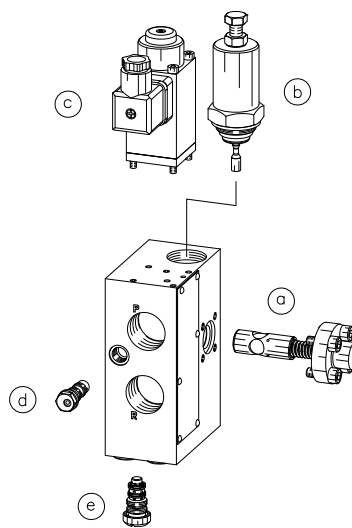
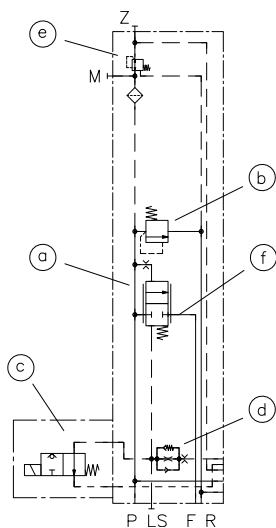
PSV



PSM



Depending on configuration, the connection blocks incorporate:



- A 3-way controller for open centre systems with constant pump
- A pressure-limiting valve to ensure maximum system pressure
- An LS pressure-limiting valve to cap or relieve LS pressure
- A damping element to attenuate LS signal oscillation
- A pressure-reducing valve for internal control oil supply to the downstream valve sections
- Various additional elements (e.g. idle circulation valve, power-beyond function, P-gallery shut-off, mechanical locking of the 3-way controller)

Order coding example:

PSL 4 Y	H	G	1	F	/420	- 3
						Size "Table 9"
						System pressure limitation "Table 8"
						LS relief or LS pressure limitation "Table 7"
						Internal control oil supply "Table 6"
						LS damping "Table 5"
						Additional elements for 3-way controller "Table 4"

- Basic type
- ["Table 1 Basic version"](#)
 - ["Table 2 Connections for P and R"](#)
 - ["Table 3 Connection block basic types"](#)

Table 1 Basic version

Type	Description
PSL	Connection block with integrated 3-way controller for use in open centre systems with constant pumps
PSV	Connection block without 3-way controller for use in closed centre systems with variable pumps or for simultaneous supply of two or more manifolds from a shared constant pump
PSM	Connection block capable of switching between open centre and closed centre

i NOTE

For instructions on how to convert the connection block from PSL to PSV, refer to [Chapter 5.2.3](#)

Table 2 Connections

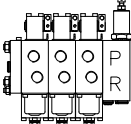
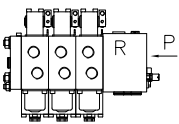
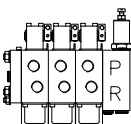
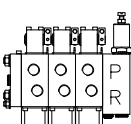
Coding	Description of P and R port
3	G 1/2 (ISO 228-1) (BSPP)
4	G 3/4 (ISO 228-1) (BSPP)
45	P connection: G 3/4 (ISO 228-1) (BSPP) R connection: G 1 (ISO 228-1) (BSPP)
5, 55	G 1 (ISO 228-1) (BSPP)
6	G 1 1/4 (ISO 228-1) (BSPP)
UNF 4, UNF 44	SAE-12 or 1 1/16-12 UN-2B (SAE J 514)
UNF 5	SAE-16 or 1 5/16-12 UN-2B (SAE J 514)
JIS 4	G 3/4 (JIS B 2351)

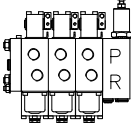
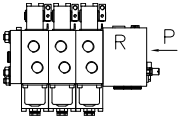
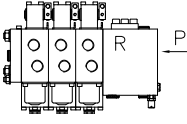
i NOTE

When combining a PSL 5, PSV 55 and PSM 5 connection block with a valve section with ancillary block (coding SL 3-A...), you will to fit a 5-mm spacer plate (SL 3-ZPL 33/5) behind the ancillary block to prevent the R connection from impacting on the ancillary block when screwing it on.

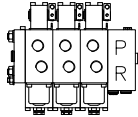
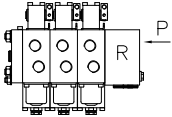
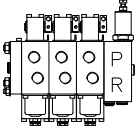
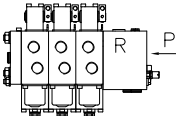
Table 3 Connection block basic types

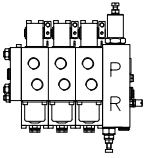
PSL connection blocks

Type	Description
<p>PSL 3.../...-3 PSL 4.../...-3 PSL JIS 4.../...-3</p>	<p>Standard connection block with integrated 3-way controller.</p> <p>Pressure-limiting valve: direct actuation P port: aligned toward consumer ports A/B</p> 
<p>PSL 45.../...-3 PSL 5.../...-3 PSL UNF 4.../...-3</p>	<p>Standard connection block with integrated 3-way controller.</p> <p>Pressure-limiting valve: pilot-controlled P connection: on side</p> 
<p>PSL 4 Y.../...-3 PSL UNF 4 Y.../...-3</p>	<p>Special version with an additional connection suitable for pressure loads for the 3-way controller's outflow (power beyond function).</p> <p>You can connect a second manifold to the F connection. The first manifold's valve sections are prioritised. The second manifold's valve sections are supplied with the remaining flow.</p> <p>Pressure-limiting valve: direct actuation P port: aligned toward consumer ports A/B</p> 
<p>PSL 4 Z.../...-3</p>	<p>Special version with LS damper valve type G as per "Table 5 LS damping" and an additional release valve.</p> <p>The release valve provides rapid LS relief when all directional spool valves are in neutral position. Once all valve sections signal an LS pressure below around 1/3 of the 3-way controller's spring cavity pressure, the release valve opens and funnels pressure from the spring cavity to the reflux.</p> <p>Version Z combines good damping with rapid relief. Common applications include oscillation-sensitive systems and combinations with load-holding valves.</p> <p>Pressure-limiting valve: direct actuation P port: aligned toward consumer ports A/B</p> 

Type	Description
<p>PSL 4 K.../...-3</p>	<p>Special version with cascade damping and an additional release valve.</p> <p>The release valve provides rapid LS relief when all directional spool valves are in neutral position. Once all valve sections signal an LS pressure below around 1/3 of the 3-way controller's spring cavity pressure, the release valve opens and funnels pressure from the spring cavity to the reflux.</p> <p>Version K combines good damping characteristics with rapid relief. Common applications include oscillation-sensitive systems and combinations with load-holding valves.</p> <p>Pressure-limiting valve: direct actuation P port: aligned toward consumer ports A/B</p> 
<p>PSL 45 U.../...-3 PSL 5 U.../...-3</p>	<p>Special version with an additional idle circulation valve for automatic reduction of circulation pressure.</p> <p>The idle circulation valve opens when the current LS pressure drops below 25% of pump pressure. Electro-hydraulic actuation with internal control oil supply requires a pump flow rate of at least 80 lpm, pilot pressure will otherwise not suffice to elevate the spool. Load pressure must be at least 20 bar.</p> <p>Pressure-limiting valve: pilot-controlled P connection: on side</p> 
<p>PSL 6...UC 22 2/...-3</p>	<p>Special version with an additional, electrically controlled idle circulation valve for reducing circulation pressure specially at flow rates.</p> <p>The idle circulation valve reduces circulation pressure to approx. 2.5 bar, resulting in improved energy efficiency in unpressurised circulation. It can be activated/deactivated by an electric pilot valve. Common applications are road vehicles with large constant pumps that frequently run in unpressurised circulation (e.g. municipal trucks).</p> <p>Pressure-limiting valve: pilot-controlled P connection: on side</p>  <p>Order coding example: PSL 61 F UC22 2/350-3</p>

PSV connection blocks

Type	Description
<p>PSV 3...-3 PSV 4...-3 PSV 5...-3 PSV 6...-3 PSV UNF 4...-3</p>	<p>Standard connection block without 3-way controller.</p> <p>Pressure-limiting valve: without P port for coding 3, 4, 5 and UNF 4: aligned towards consumer ports A/B P connection for coding 6: on side</p> <div style="display: flex; justify-content: space-around; align-items: flex-start;"> <div style="text-align: center;"> <p>Coding 3, 4, 5, UNF 4</p>  </div> <div style="text-align: center;"> <p>Coding 6</p>  </div> </div> <p>PSV 6...-3 cannot be combined with an LS release valve or LS pressure-limiting valve from "Table 7" .</p>
<p>PSV 3.../...-3 PSV 4.../...-3 PSV 5.../...-3</p>	<p>Standard connection block without 3-way controller.</p> <p>Pressure-limiting valve: direct actuation P port: aligned toward consumer ports A/B</p> 
<p>PSV 45.../...-3 PSV 55.../...-3 PSV UNF 44.../...-3</p>	<p>Standard connection block without 3-way controller.</p> <p>Pressure-limiting valve: pilot-controlled P connection: on side</p> 

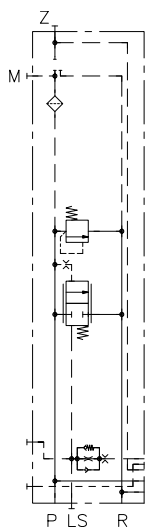
Type	Description
<p>PSV 5 N.../.../...-3 PSV UNF 5 N.../.../...-3</p>	<p>Special version with additional P-gallery shut-off to safely shut off pump and consumer from one another and prevent undesired movements.</p> <p>The P gallery incorporates a piston controlled by a 2/2-way directional valve. When unpowered, the piston securely seals the P gallery, actuating the 2/2-way directional valve opens the P gallery.</p> <ul style="list-style-type: none"> ▪ N: 2/2-way directional valve type EM 11 S as per D 7490/1 ▪ NM: with wing bolt for mechanical locking (EM 11 S-...-M) ▪ NP: with button for manual override (EM 11 ST) <p>Only possible in conjunction with LS damping (see "Table 5")</p> <p>Optionally, an additional LS release valve is available to depressurise the LS signal and switch the variable pump to standby pressure.</p> <ul style="list-style-type: none"> ▪ PSV (UNF) 5 N V: LS relief, closed when unpowered (EM 11 V as per D 7490/1) ▪ PSV (UNF) 5 N Z: LS relief, open when unpowered (EM 11 S as per D 7490/1) ▪ PSV (UNF) 5 N ZM: LS relief, open when unpowered, with wing bolt for mechanical locking (EM 11 S-...-M) ▪ PSV (UNF) 5 N ZP: LS relief, open when unpowered, with button for manual override (EM 11 ST) <p>Order coding example: PSV 5 NMB 61ZM/220/200-3</p> <ul style="list-style-type: none"> - Setting for main pressure-limiting valve: 220 bar - Setting for LS pressure-limiting valve: 200 bar <p>Pressure-limiting valve: direct actuation P port: aligned toward consumer ports A/B</p>  <div style="border: 1px solid gray; padding: 10px; margin-top: 10px;"> <p>i NOTE</p> <p>When using a P-gallery shut-off, there is an additional pressure drop in the P gallery that can lead to the downstream sections no longer reaching nominal flow.</p> <p>Nominal flow undercut depends on</p> <ol style="list-style-type: none"> a) control pressure difference in the variable pump's pump controller, b) position of the valve sections in the manifold and c) flow rate through the P-gallery shut-off. <p>Nominal flow undercut can reach up to 30% of Q_{nominal}, see also "Table 15: Flow rate".</p> </div>

PSM connection blocks

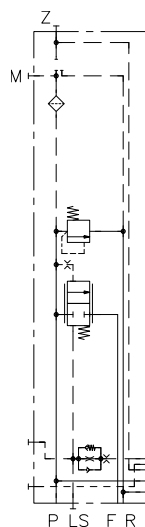
Type	Description
PSM 5.../...-3 PSM UNF 4.../...-3	<p>Special version capable of switching between open centre and closed centre. Switchover is performed using an external 3/2-way directional valve. This valve is not included.</p> <p>Pressure-limiting valve: pilot-controlled P connection: on side</p>
PSM 5 L.../...-3	<p>Special version capable of switching between open centre and closed centre. Switchover is performed using an integrated 3/2-way directional valve.</p> <p>Pressure-limiting valve: pilot-controlled P connection: on side</p>

Circuit symbols

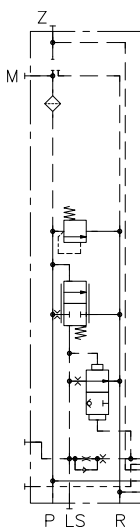
PSL 3.../...-3
PSL 4.../...-3
PSL JIS 4.../...-3



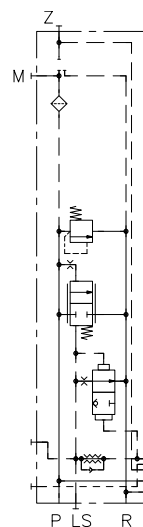
PSL 4 Y.../...-3
PSL UNF 4 Y.../...-3



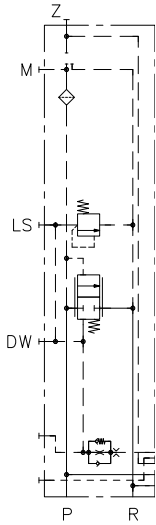
PSL 4 Z.../...-3



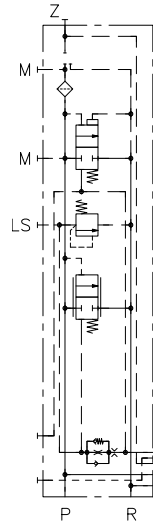
PSL 4 K.../...-3



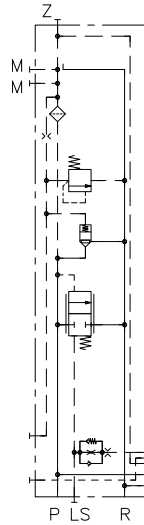
PSL 45.../...-3
PSL 5.../...-3
PSL UNF 4.../...-3



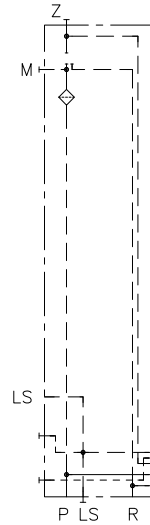
PSL 45 U.../...-3
PSL 5 U.../...-3



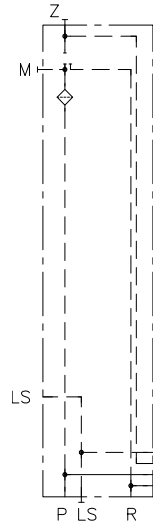
PSL 6...UC 22 2/...-3



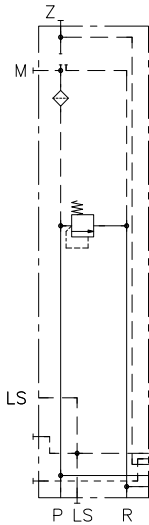
PSV 3...-3, PSV 4...-3
PSV 5...-3, PSV UNF 4...-3



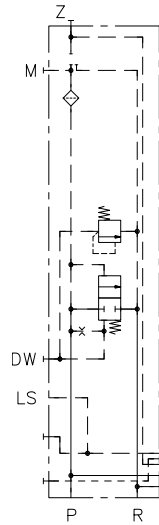
PSV 6...-3



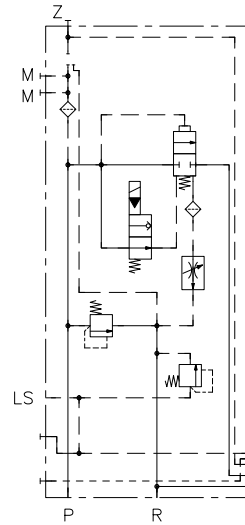
PSV 3.../...-3
PSV 4.../...-3
PSV 5.../...-3



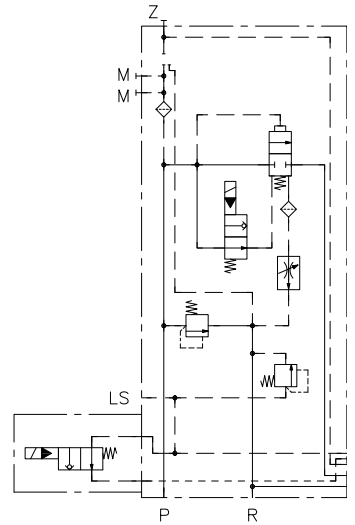
PSV 45.../...-3
PSV 55.../...-3
PSV UNF 44.../...-3



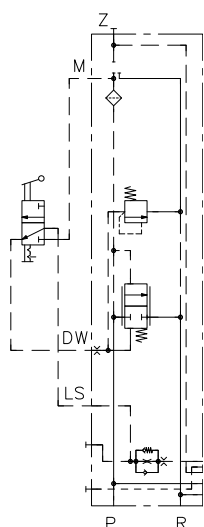
PSV 5 N.../.../...-3
PSV UNF 5 N.../.../...-3



PSV 5 N...Z/.../...-3

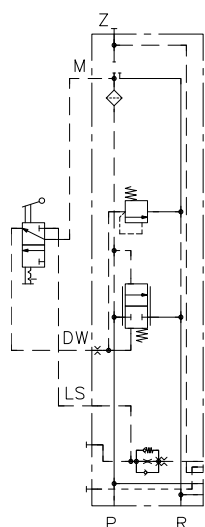


PSM 5.../...-3
PSM UNF 4.../...-3



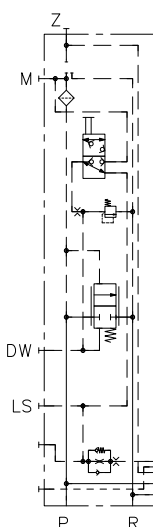
Schematic for constant pump systems

PSM 5.../...-3
PSM UNF 4.../...-3



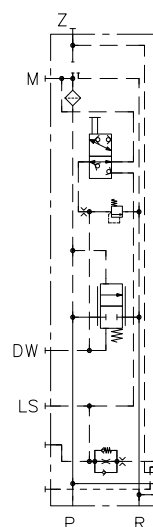
Schematic for variable pump systems

PSM 5 L.../...-3



Schematic for constant pump systems

PSM 5 L.../...-3



Schematic for variable pump systems

Table 4 Additional elements for 3-way controller (only PSL and PSM)

Coding	Description
No designation	Standard version 3-way controller with 9 bar circulation pressure
H	Special version 3-way controller with higher circulation pressure (14 bar)
T, TR	Special version for mechanical locking of the 3-way controller Only for connection blocks type PSL 3 and PSL 4 <ul style="list-style-type: none"> ▪ T: Tool adjustable ▪ TR: manually adjustable using turn knob







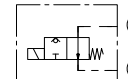

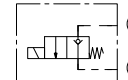

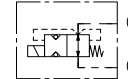

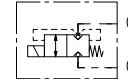

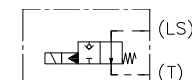

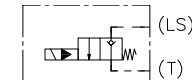
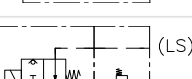
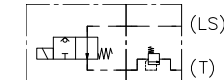

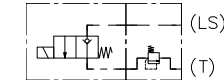

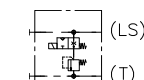

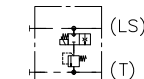

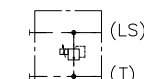
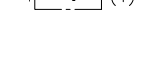
Table 5 LS damping

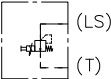
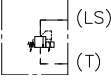


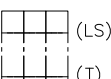
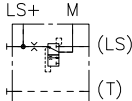
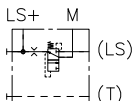
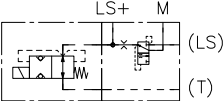
Coding	Description	Circuit symbol
No designation	<ul style="list-style-type: none"> For PSL and PSM: as for coding S For PSV: without LS damping 	
B	∅ 0.8 mm orifice plate	
B 4	∅ 0.4/0.5/0.6/0.7 mm orifice plate	
B 5		
B 6		
B 7		
B 55	Two ∅ 0.5 mm orifice plates in series	
S	Pre-load and damper valve (pre-load pressure: 25 bar)	
W	Pre-load and damper valve with increased throttle effect (pre-load pressure: 25 bar)	
E	<p>Damper valve without pre-load valve</p> <p>Because there is no pre-load valve, LS relief with all directional spool valves in neutral position occurs with a slight delay, system pressure drops only slowly. Common applications include consumers with a tendency to oscillate at low frequencies.</p>	
G	<p>Damper valve with increased throttle effect without pre-load valve</p> <p>Because there is no pre-load valve, LS relief with all directional spool valves in neutral position occurs with a slight delay, system pressure drops only slowly. Common applications include consumers with a tendency to oscillate at low frequencies.</p>	

Table 6 Internal control oil supply

Coding	Description	Circuit symbol
No designation	<p>Without internal control oil supply</p> <p>For valve sections with manual, hydraulic or pneumatic actuation. Or for external control oil supply (required pilot pressure: 20 to 40 bar).</p>	
1, 2	<p>With internal control oil supply</p> <p>For valve sections with electro-hydraulic actuation. Optionally, a small quantity of control oil can be siphoned from the Z connection to supply externally connected additional valves. In this case, maximum permissible flow rate is 2 lpm.</p> <ul style="list-style-type: none"> 1: 20 bar pilot pressure 2: 40 bar pilot pressure 	

Table 7 LS relief or LS pressure limitation

Coding	Description	Circuit symbol
No designation	Without LS relief or LS pressure limitation	 (LS)  (T)
X...	LS pressure limitation (Adjustment range: 50 to 400 bar)	 (LS)  (T)
VX...	LS pressure limitation (Adjustment range: 50 to 400 bar) Prepared for later conversion to coding ZD..., ZDM..., ZDP... or VD...	 (LS)  (T)
F	LS relief, open when unpowered (WN 1 F as per D 7470 A/1)	 (LS)  (T)
D	LS relief, closed when unpowered (WN 1 D as per D 7470 A/1)	 (LS)  (T)
F BVE	LS relief, open when unpowered (BVE 1 R as per D 7921) Combined with solenoid version G 24 EX 55 FM only approved for up to 250 bar.	 (LS)  (T)
D BVE	LS relief, open when unpowered (BVE 1 S as per D 7921) Combined with solenoid version G 24 EX 55 FM only approved for up to 250 bar.	 (LS)  (T)
ZA ZAM ZAP	LS relief, open when unpowered <ul style="list-style-type: none"> ▪ ZA: EM 11 S as per D 7490/1 ▪ ZAM: with wing bolt for mechanical locking (EM 11 S-...-M) ▪ ZAP: with button for manual override (EM 11 ST) 	 (LS)  (T)
VA	LS relief, closed when unpowered (EM 11 V as per D 7490/1)	 (LS)  (T)
F...	Switchable LS pressure limitation, active when unpowered (WN 1 F as per D 7470 A/1) (Adjustment range: 50 to 400 bar)	 (LS)  (T)
D...	Switchable LS pressure limitation, disabled when unpowered (WN 1 D as per D 7470 A/1) (Adjustment range: 50 to 400 bar)	 (LS)  (T)
ZD... ZDM... ZDP...	Switchable LS pressure limitation, active when unpowered. <ul style="list-style-type: none"> ▪ ZD...: EM 21 DS as per D 7490/1 E ▪ ZDM...: with wing bolt for mechanical locking (EM 21 DS-...-M) ▪ ZDP...: with button for manual override (EM 21 DST) 	 (LS)  (T)
VD...	Switchable LS pressure limitation, disabled when unpowered (EM 21 D as per D 7490/1 E)	 (LS)  (T)
PA PB PC PD	Proportional LS pressure limitation with ascending characteristics <p>Pressure ranges:</p> <ul style="list-style-type: none"> ▪ PA: 35 to 320 bar ▪ PB: 25 to 210 bar ▪ PC: 40 to 400 bar ▪ PD: 50 to 420 bar 	 (LS)  (T)

Coding	Description	Circuit symbol
Z ZM ZP	Proportional LS pressure limitation with ascending characteristics <ul style="list-style-type: none"> ▪ Z: EM 21 DSE as per D 7490/1 E ▪ ZM: with wing bolt for mechanical locking (EM 21 DSE-...-M) ▪ ZP: with button for manual override (EM 21 DSET) 	 (LS) (T)
V	Proportional LS pressure limitation with descending characteristics (EM 21 DE as per D 7490/1)	 (LS) (T)
X9 X18 X27	Intermediate plate for turning the downstream valve for LS relief or LS pressure limitation <ul style="list-style-type: none"> ▪ X9: Turns clockwise through 90° ▪ X18: Turns through 180° ▪ X27: Turns clockwise through 270° 	X9  (LS) (T) X18  (LS) (T) X27  (LS) (T)
Z ADM 0 Z ADM 3	Intermediate plate with copier valve for amplifying LS signal <ul style="list-style-type: none"> ▪ 0: without LS pressure amplification ▪ 3: with 3 bar LS pressure amplification <p>The M connection of the copier valve is connected externally to the M connection on the connection block. Optionally, additional LS+ damping is possible.</p> <p>The copier valve is designed as intermediate plate. Connection T and LS+ are usually sealed.</p> <p>If required, you can connect a release valve type F, D, F BVE or D BVE there (e.g. Z ADM 0/F BVE).</p>	Z ADM 0  (LS) (T) Z ADM 3  (LS) (T) Z ADM 0/F BVE  (LS) (T)

i NOTE
 LS release valves and LS pressure-limiting valves of types X..., VX..., ZA, ZAM, ZAP, VA, F..., D..., ZD..., ZDM..., ZDP..., VD..., PA, PB, PC, PD, Z, ZM, ZP and V require limiting the intake by means of LS damping as per ["Table 5"](#) in order to ensure reliable relief/pressure limitation.

i NOTE
 If LS pressure-limiting valves of types PA, PB, PC, PD, Z, ZM, ZP and V are used for the emergency stop function, it is important to note that a certain residual pressure will always remain while the spool is elevated and there is a pressure load.

LS damping as per "Table 5"	Residual pressure at load pressure of	
	250 bar	350 bar
B, S, W, E, G	125	150
B 4	60	70
B 5	75	80
B 6	85	95
B 7	100	120

Table 8 System pressure limitation

Coding	Description
No designation	Without pressure-limiting valve
/...	with pressure-limiting valve (adjustment range 50 to 420 bar)
/.../...	With pressure-limiting valve and LS pressure-limiting valve (only for PSV 5 N and PSV UNF 5 N) The first value is the setting for the main pressure-limiting valve, the second value is the setting for the LS pressure-limiting valve.

Table 9 Size

Coding	Description
- 3	Size 3

For size 2 see [D 7700-2](#), for size 5 see [D 7700-5](#)

List of available connection block variants and combination options:

PSL connection blocks

Type	P and R connection as per ISO 228-1 (BSPP) or SAE J 514 or JIS B 2351	Pressure-limiting valve		Position of P connection	
		direct actuation	pilot-controlled	aligned toward consumer ports A/B	on side, with horizontal intake
PSL 3.../...-3	G 1/2	●		●	
PSL 4.../...-3	G 3/4	●		●	
PSL 4 Y.../...-3	G 3/4	●		●	
PSL 4 Z.../...-3	G 3/4	●		●	
PSL 4 K.../...-3	G 3/4	●		●	
PSL 45.../...-3	G 3/4 and G 1		●		●
PSL 5.../...-3	G 1		●		●
PSL 45 U.../...-3	G 3/4 and G 1		●		●
PSL 5 U.../...-3	G 1		●		●
PSL 6...UC 22 2/...-3	G 1 1/4		●		●
PSL UNF 4.../...-3	SAE-12 (1 1/16-12 UN-2B)		●		●
PSL UNF 4 Y.../...-3	SAE-12 (1 1/16-12 UN-2B)	●		●	
PSL JIS 4.../...-3	JIS G 3/4	●		●	

PSV connection blocks

Type	P and R connection as per ISO 228-1 (BSPP) or SAE J 514	Pressure-limiting valve			Position of P connection	
		None	direct actuation	pilot-controlled	aligned toward consumer ports A/B	on side, with horizontal intake
PSV 3...-3	G 1/2	●			●	
PSV 4...-3	G 3/4	●			●	
PSV 5...-3	G 1	●			●	
PSV 6...-3	G 1 1/4	●				●
PSV 3.../...-3	G 1/2		●		●	
PSV 4.../...-3	G 3/4		●		●	
PSV 5.../...-3	G 1		●		●	
PSV 45.../...-3	G 3/4 and G 1			●		●
PSV 55.../...-3	G 1			●		●
PSV 5 N...-3	G 1		●		●	
PSV UNF 4...-3	SAE-12 (1 1/16-12 UN-2B)	●			●	
PSV UNF 44.../...-3	SAE-12 (1 1/16-12 UN-2B)			●		●
PSV UNF 5 N...-3	SAE-16 (1 5/16-12 UN-2B)		●		●	

PSM connection blocks

Type	P and R connection as per ISO 228-1 (BSPP) or SAE J 514	Pressure-limiting valve		Position of P connection	
		direct actuation	pilot-controlled	aligned toward consumer ports A/B	on side, with horizontal intake
PSM 5.../...-3	G 1		●		●
PSM 5 L.../...-3	G 1		●		●
PSM UNF 4.../...-3	SAE-12 (1 1/16-12 UN-2B)		●		●

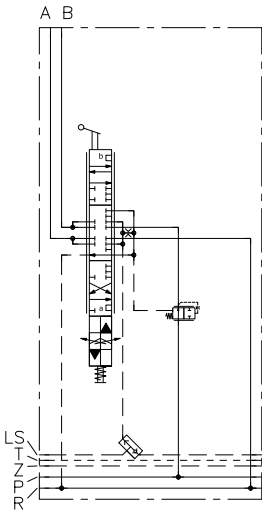
i NOTE

In [Chapter 3.2, "Characteristics"](#) you can find the dynamic pressure characteristics for the various connection blocks. The characteristics assist in choosing a connection block suitable for the respective flow rate.

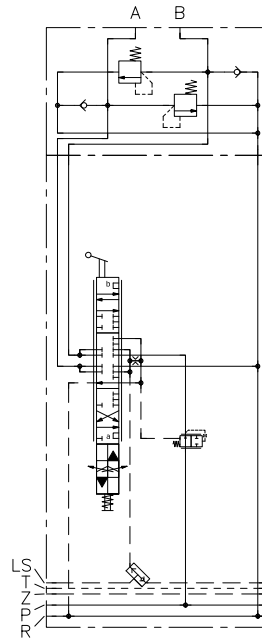
2.3 Valve section

The directional valve section ([Chapter 2.3.1](#)) is available either with integrated threads for consumer ports A and B or with flange surface for mounting an ancillary block ([Chapter 2.3.2](#)) or intermediate plate ([Chapter 2.3.3](#)).

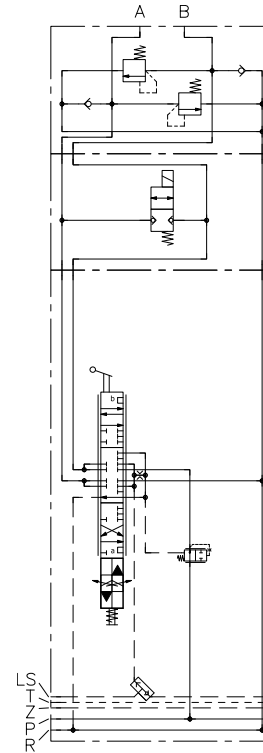
**Valve section
with integrated threads**



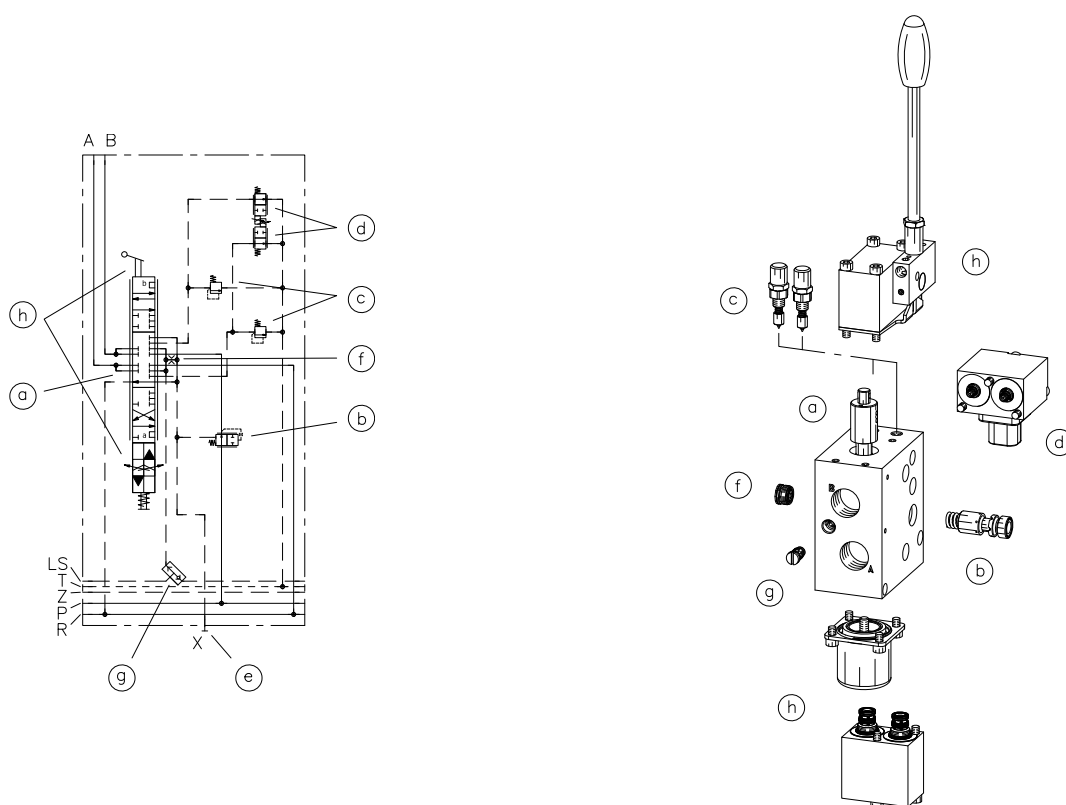
**Valve section
with ancillary block**



**Valve section
with intermediate plate and ancillary
block**



Depending on configuration, the directional valve sections incorporate:



- a. A valve spool for controlling proportional flow rate
- b. A 2-way controller (pressure compensator) for controlling a constant pressure difference using the valve spool, irrespective of the current load pressure and pump pressure
- c. Permanently set LS pressure-limiting valves
- d. Electric LS pressure-limiting valves for relieving the electro-proportional LS pressure limitation
- e. Additional connections for external LS pressure limitation
- f. An LS orifice for damping the LS signal
- g. A shuttle valve for linking the LS line to additional valve sections
- h. An actuation for elevating the valve spool

Order coding example:

SL 3	- A	R5X	H 80/80	A200 B300 F3 XH	9	W3	L	/EFA1	WA	/ZDRH	/3
											Chapter 2.3.2, "Ancillary block"
											Chapter 2.3.3, "Intermediate plate"
										Switching position monitoring, displacement transducer	"Table 24"
									Actuation	<ul style="list-style-type: none"> ▪ "Table 22 Actuation" ▪ "Table 23 Additional description for actuation" 	
									Additional functions	"Table 21"	
									Shuttle valve	"Table 20"	
									LS orifice	"Table 19"	
									LS pressure limitation	<ul style="list-style-type: none"> ▪ "Table 16 LS pressure limitation" ▪ "Table 17 Electric LS pressure limitation" ▪ "Table 18 LS port for external limitation " 	
									Valve spool	<ul style="list-style-type: none"> ▪ "Table 14 Circuit symbol" ▪ "Table 15 Flow rate" 	
									Valve section, 2-way controller	<ul style="list-style-type: none"> ▪ "Table 11 Valve section, 2-way controller" ▪ "Table 12 2-way controller spring" ▪ "Table 13 2-way controller damping" 	
									Consumer ports	"Table 10"	

2.3.1 Directional valve section

Table 10 Consumer ports

Coding	Description
A	Spool block without integrated threads for combining with an ancillary block (Chapter 2.3.2) or intermediate plate (Chapter 2.3.3)
3	Consumer ports A and B in G 1/2 (ISO 228-1) (BSPP)
4	Consumer ports A and B in G 3/4 (ISO 228-1) (BSPP)
UNF 3	Consumer ports A and B in SAE-10 or 7/8-14 UNF-2B (SAE J 514) Only in conjunction with <ul style="list-style-type: none"> ▪ actuation coding E... (see also "Table 22") ▪ LS pressure limitation without designation or coding AB, A..., B,,, or A... B... (see also "Table 16")
UNF 4	Consumer ports A and B in SAE-12 or 1 1/16-12 UN-2B (SAE J 514) Only in conjunction with <ul style="list-style-type: none"> ▪ actuation coding E... (see also "Table 22") ▪ Valve section coding 8 (see also "Table 11")

i NOTE

When combining a PSL 5, PSV 55 and PSM 5 connection block with a valve section with ancillary block (coding SL 3-A...), you will fit a 5-mm spacer plate (SL 3-ZPL 33/5) behind the ancillary block to prevent the R connection from impacting on the ancillary block when screwing it on.

Table 11 Valve section, 2-way controller

Coding	Description	Circuit symbol
No designation	Standard 2-way controller	
1	Without 2-way controller	--
R	<p>2-way controller with check valve function</p> <p>In the event of a shortage in supply, the controller prevents return flow from the load line (A or B gallery) to the P gallery.</p> <p>Only in conjunction with 2-way controller spring coding 2 and 5 see also "Table 12"</p>	
D	<p>2-way controller with release of pressure</p> <p>The controller prevents pressure creep in the P gallery between the 2-way controller and valve spool.</p> <p>Common applications include consumers with very low load pressures and without additional check valves. With standard 2-way controllers, phantom movements may occur here. The pressure controller prevents this.</p> <p>In applications with check valves, the pressure controller prevents undesired check valve intervention.</p>	
I	<p>Special controller with ascending characteristics</p> <p>The controller has inclined characteristics. Flow rate increases with increasing differential pressure.</p> <div data-bbox="319 1108 877 1590"> <p>Q flow rate (lpm); Δp differential pressure (bar)</p> </div> <p>Common applications include drives for tracked crawlers. In these, one side is always slightly ahead, its load pressure thus higher. The controller makes driving straight ahead easier by automatically accelerating the lagging side and neutralising the offset between the two sides.</p>	

Coding

Description

Circuit symbol

8

Pre-selector valve section without 2-way controller

The pre-selector valve section shuts off the P gallery in neutral position. Once the pre-selector valve activates, it supplies either the downstream valve sections (switching position b) or a second manifold connected to connection A (switching position a).

If an open centre valve is connected to connection A, selecting the pre-selector valve's default configuration is recommended. This will internally produce an LS signal that is sent to the shuttle valve.

If a closed centre LS valve is connected to connection A, that valve will usually send the LS signal externally to the variable pump. In this case, shuttle valve coding W1 is recommended (see also "Table 20") as this will stop the pre-selector valve from sending an LS signal in switching position a.

Common applications include loading cranes, concrete line pumps and lifting platforms. In these, the pre-selector valve is used to switch between operating the crane or mast and the outriggers. The pre-selector valve can further also be used as a P-gallery shut-off in safety functions.

Only in conjunction with

- PSL connection block with 3-way controller spring coding H (see also "Table 4") or PSV connection block
- Consumer ports 3, 4 or UNF 4 (see also "Table 10 ")
- Circuit symbol L or H (see also "Table 14")
- actuation coding E... (see also "Table 22")

i NOTE

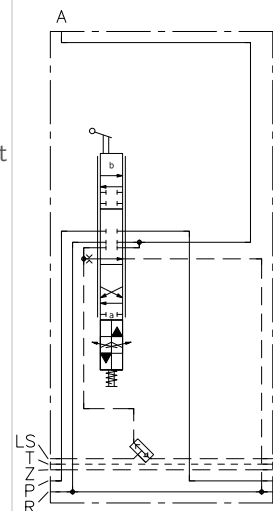
When using a pre-selector valve, there is an additional pressure drop in the P gallery that can lead to the downstream sections no longer reaching nominal flow.

Nominal flow undercut depends on

- a) control pressure difference of the 3-way controller (PSL) or variable pump's pump controller (PSV),
- b) position of the valve sections in the manifold and
- c) flow rate through the pre-selector valve or P-gallery shut-off.

Nominal flow undercut can reach up to 30% of Q_{nominal} , see also "Table 15: Flow rate".

- Standard



- With shuttle valve W1

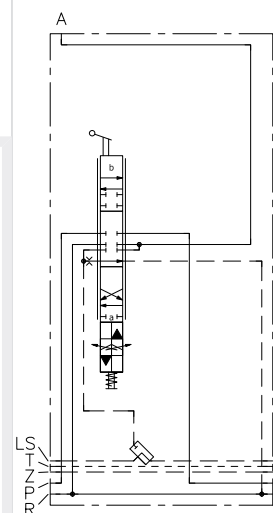


Table 12 2-way controller spring

Coding	Description
No designation	Without coding for configurations without 2-way controller (coding 1 or 8 as per "Table 11")
2	Standard version (6 bar spring)
5	Heavy-duty version (9 bar spring) Only in conjunction with PSL connection block with 3-way controller spring coding H ("Table 4") or with PSV connection block
7	Heavy-duty version (13 bar spring) Only possible in conjunction with PSV connection block

Table 13 2-way controller damping

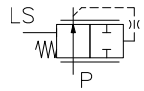
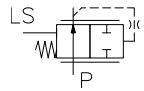
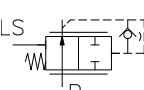
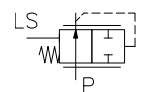
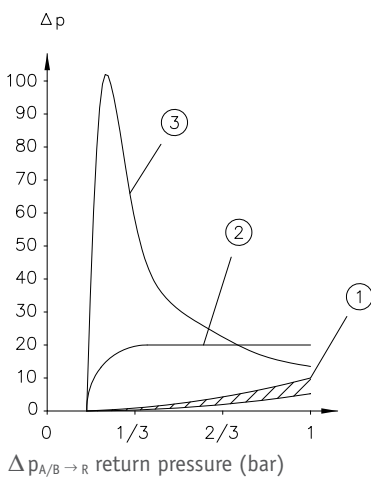
Coding	Description	Circuit symbol
No designation	Standard version (damping with \varnothing 0.5 mm orifice)	
4 6D	Special version with stronger or weaker damping (\varnothing 0.4 or 0.6 mm orifice) <ul style="list-style-type: none"> 4: only in conjunction with standard 2-way controller (without designation) see also "Table 11" 6D: only in conjunction with standard 2-way controller (without designation) or 2-way controller way controller with check valve function (coding R) see also "Table 11" 	
S	Special version with closing damping Only in conjunction with standard 2-way controller (without designation) see also "Table 11"	
X	Special version without damping Only in conjunction with standard 2-way controller (without designation) or 2-way controller way controller with check valve function (coding R) see also "Table 11"	

Table 14 Circuit symbol

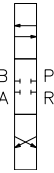
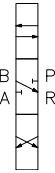
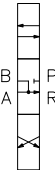
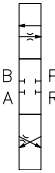
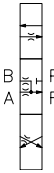
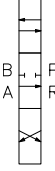
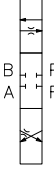
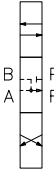
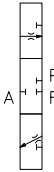
Coding	Description	Circuit symbol			
L, M, F, H	Standard spool valve with low return pressure				
J, B, R, O	Standard spool valve with constant return pressure 20 bar Common applications: Stabilising cylinders with dragging loads, especially when used with load-holding valves or when used without additional check valves.				
I, Y, Z, V	Standard spool valve with high reflux at < 1/3 spool valve elevation and rapid subsequent return pressure drop Common applications: Controlled deceleration of winches, slewing gear or other rotating consumers.				

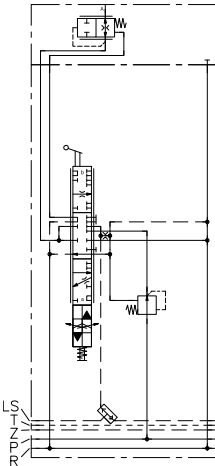
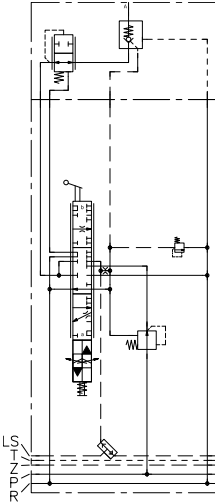


- 1 Circuit symbols L, M, F, H
- 2 Circuit symbols J, B, R, O
- 3 Circuit symbols I, Y, Z, V

i NOTE

Return pressure in relation to nominal flow rate. It may be higher or lower than shown in the diagram depending on the cylinder ratio or 2-way controller spring.

Coding	Description	Circuit symbol					
LW, MW, HW, JW, OW	Special version with broad fitting tolerance. <ul style="list-style-type: none"> ▪ Advantage: Reduces risk of jamming spool valve in systems prone to soiling ▪ Drawback: higher spool valve leak rate 	LW 	MW 	HW 	JW 	OW 	
FE, JE	Special version with tight fitting tolerance. <ul style="list-style-type: none"> ▪ Advantage: lower spool valve leak rate ▪ Drawback: greater hysteresis Spool valves with tight fitting tolerance cannot be replaced later.					FE 	JE 
LB	Special version with minimal release of pressure from A and B gallery when spool valve in idle position. <p>Common applications: Combined with load-holding valves that require closed spool valve in idle position for safety reasons. The LB spool valve in such a case prevents trapping pressure between spool valve and load-holding valve and allows the load-holding valve to close reliably.</p>					LB 	
G	3/3-way controller for single-acting cylinders <p>The G spool valve can be combined with any valve section, port B is sealed with a tapped plug when doing so.</p> <p>No LS signal is produced when load drops. When combined with electro-hydraulic actuation and a PSL connection block with standard 3-way controller spring (see also "Table 4"), this may lead to the internally generated pressure failing to fully elevate the spool valve.</p> <p>Load reduction is throttled using the spool valve's outflow edge. If desired, the maximum reduction rate can be capped using a separate flow control valve (e.g. type SB as per D 6920).</p> <p>To obtain pressure-compensated load reduction, you can alternatively also use an N or NX spool valve.</p>					G 	

Coding	Description	Circuit symbol
N	<p>3/3-way controller for single-acting cylinders with outflow pressure compensator for pressure-compensated load reduction.</p> <p>The N spool valve is combined with a valve section designed specifically for this purpose and cannot be used with any other valve sections.</p> <p>No LS signal is produced when load drops. When combined with electro-hydraulic actuation and a PSL connection block with standard 3-way controller spring (see also "Table 4"), this may lead to the internally generated pressure failing to fully elevate the spool valve.</p> <p>Not compatible with LS pressure limitation and only in conjunction with</p> <ul style="list-style-type: none"> ▪ ancillary block coding /3 DW, /4 DW or /UNF 3 DW (see also Chapter 2.3.2, "Ancillary block") ▪ Consumer ports coding A (see also "Table 10") ▪ actuation coding E... (see also "Table 22") 	 <p>The diagram shows a 3/3-way valve with a pressure-compensating spool valve. It includes a 3-way controller with a spring, a pressure-compensating valve, and a check valve. The ports are labeled LS, T, P, and R. The LS signal is not produced when load drops.</p>
NX	<p>3/3-way controller for single-acting cylinders with outflow pressure compensator and releasable check valve for pressure-compensated load reduction and load holding without leaking seating.</p> <p>The NX spool valve is combined with a valve section designed specifically for this purpose and cannot be used with any other valve sections.</p> <p>An LS signal is produced internally when load drops. The LS pressure is used to actuate opening of the releasable check valve and can be set to a maximum limit value with an integrated LS pressure-limiting valve. The LS pressure-limiting valve only acts when load drops.</p> <p>Only in conjunction with</p> <ul style="list-style-type: none"> ▪ ancillary block coding /4.. HRP 4, /4.. HRP 4 V, /4.. HRP 4, or /4.. HRP 4 V (see also Chapter 2.3.2, "Ancillary block") ▪ Consumer ports coding A (see also "Table 10") ▪ LS pressure limitation coding A... (see also "Table 16") ▪ actuation coding E... (see also "Table 22") 	 <p>The diagram shows a 3/3-way valve with a pressure-compensating spool valve and a releasable check valve. It includes a 3-way controller with a spring, a pressure-compensating valve, and a check valve. The ports are labeled LS, T, P, and R. The LS signal is produced internally when load drops.</p>

Coding	Description	Circuit symbol				
X, W	<p>Special version in conjunction with P → A in neutral position</p> <p>Common applications: Fan drives, generator drives or other consumers requiring a specific flow rate when unpowered for safety reasons.</p> <ul style="list-style-type: none"> ▪ X: 2/2-way controller Maximum flow rate in neutral position. By shifting the spool valve to switching position b, the flow rate can be reduced to zero proportionally. ▪ W: 4/2-way controller Neutral position shunts maximum flow to A side. Shifting spool valve to switching position b, direction is reversed and flow is towards B side. Decelerating consumer to zero as well as proportional flow rate control are only possible to a limited degree. This makes the W spool valve suitable primarily for applications with constant speed. <p>Available versions:</p> <ul style="list-style-type: none"> ▪ X 80 ▪ W 50/50 	<div style="display: flex; justify-content: space-around;"> <div style="text-align: center;"> <p>X</p> </div> <div style="text-align: center;"> <p>W</p> </div> </div>				
P, A, T, Q, K	<p>Special spool valve with positive overlap</p> <p>When elevated, the spool valve first opens the duct between P and A or B and afterwards the duct from A or B to R. Briefly pre-loading the consumer prevents uncontrolled run-on.</p> <p>Common applications include hydraulic motors with self-aligning torque, synchronising cylinders with return force or differential cylinders with dragging loads.</p> <ul style="list-style-type: none"> ▪ P: Positive overlap in both directions. Only for hydraulic motors or synchronising cylinders as this would cause undesirable pressure amplification in differential cylinders. ▪ A, T: Positive overlap only in direction B. To avoid pressure amplification, choose a slightly higher flow rate coding for the A side. ▪ Q, K: Positive overlap only in direction A. To avoid pressure amplification, choose a slightly higher flow rate coding for the B side. 	<div style="display: flex; justify-content: space-around;"> <div style="text-align: center;"> <p>P</p> </div> <div style="text-align: center;"> <p>A</p> </div> <div style="text-align: center;"> <p>T</p> </div> <div style="text-align: center;"> <p>Q</p> </div> <div style="text-align: center;"> <p>K</p> </div> </div>				

i NOTE

You can find instructions on how to replace the valve spool in [Chapter 5.2.4, "Changing the valve spool"](#).

Table 15 Flow rate

Coding 2-way controller spring as per "Table 12"	Flow rate at maximum spool valve elevation ($Q_{A/B}$ in lpm) according to flow rate coding ($Q_{nominal}$)							
	3	6	10	16	25	40	63	80
2	3	6	10	16	25	40	63	80
5	4	9	14	22	34	54	85	107
7	5	10	15	24	37	59	93	118

! NOTE

The valve spools' sizes are designed to make actual flow rate slightly higher than $Q_{nominal}$ in practice. You can use stroke limitation to limit the maximum flow rate. Setting values are specified in lpm.

Order coding example: SL 3-32 L 80/80/EA [75/70]

! NOTE

When using a pre-selector valve (coding 8 as per "Table 11: Valve section, 2-way controller"), a P-gallery shut-off (coding PSV 5 N or PSV UNF 5 N as per "Table 3: Connection block basic types" or coding ZPL 3 S or ZPL 3 V as per Chapter 2.4, "Series intermediate plate") or an intermediate plate for P pressure limitation (coding ZPL 3 P/... as per Chapter 2.4, "Series intermediate plate"), there is an additional pressure drop in the P gallery that can lead to the downstream sections no longer reaching nominal flow.

Nominal flow undercut depends on

- control pressure difference of the 3-way controller (PSL) or variable pump's pump controller (PSV),
- position of the valve sections in the manifold and
- flow rate passing through the pre-selector valve or P-gallery shut-off or intermediate plate to P pressure limitation.

Nominal flow undercut can reach up to 30% of $Q_{nominal}$, see also "Table 15: Flow rate".

For valve sections without 2-way controller (coding 1 or 8 as per "Table 11"), you can calculate the flow rate by the following formula:

$$Q_{A/B} = Q_{Nenn} \cdot \sqrt{0.2 \cdot \Delta p_{Regler}}$$

$Q_{A/B}$ = flow rate to port A or B

$Q_{nominal}$ = nominal flow rate of valve spool at pressure difference of 6 bar

$\Delta p_{controller}$ = control pressure difference of the 3-way controller (PSL) or variable pump's pump controller (PSV)

Example:

- PSL connection block, standard 3-way controller spring (9 bar)

$$Q_{A/B} = 80 \text{ l/min} \cdot \sqrt{0.2 \cdot 9} = 107 \text{ l/min}$$

- PSL connection block, 3-way controller with heavy-duty spring (14 bar)

$$Q_{A/B} = 80 \text{ l/min} \cdot \sqrt{0.2 \cdot 14} = 134 \text{ l/min}$$

- PSV connection block, pump controller with 25 bar standby pressure

$$Q_{A/B} = 80 \text{ l/min} \cdot \sqrt{0.2 \cdot 25} = 179 \text{ l/min}$$

! NOTE

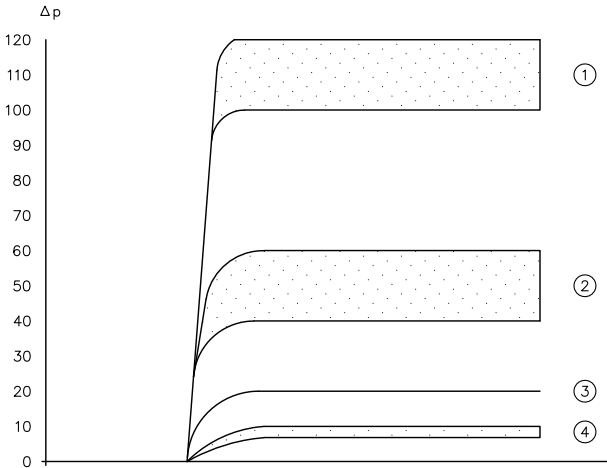
The calculate values are rough reference values! They apply to the highest-load consumer. If multiple consumers are being actuated in parallel, the pressure difference may be considerably greater at the lower-load consumers.

For spool valves with 2-digit order coding, the first number indicates nominal flow rate on the A side (Q_A) and the second number indicates nominal flow rate on the B side (Q_B). The shape of the spool valve's two outflow edges is defined by the circuit symbol (see also "Table 14").

► **Order coding example:** L 80/63, J 25/16, H 40/40, O 10/10

For J and O spool valves, the outflow edge can also be customised. In such a case, the order coding has 4 digits and looks like this: $Q_{A \rightarrow R} - Q_{P \rightarrow A} / Q_{P \rightarrow B} - Q_{B \rightarrow R}$. Choosing a lower key figure increases return pressure. A larger key figure reduces return pressure.

► **Order coding example:** J 63-80/63-40, J 25-40/63-40, O 3-6/6-3, O 16-25/25-16



- 1 Outflow edge two sizes smaller
- 2 Outflow edge one size smaller
- 3 Standard version
- 4 Outflow edge one size larger

NOTE
Return pressure in relation to nominal flow rate. It may be higher or lower than shown in the diagram depending on the cylinder ratio or 2-way controller spring.

Table 16 LS pressure limitation

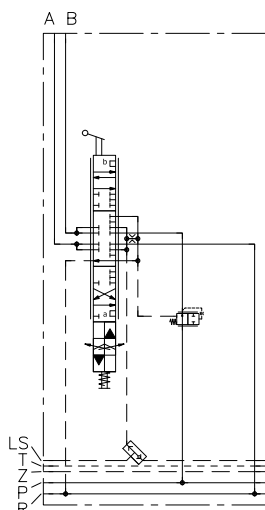
Coding	Description
No designation	Without LS pressure limitation
AB	Without LS pressure limitation, but prepared for later conversion to coding A..., B... or A... B...
A...	LS pressure limitation for A side (Adjustment range: 50 to 400 bar)
B...	LS pressure limitation for B side (Adjustment range: 50 to 400 bar)
A... B...	LS pressure limitation for A and B side with two separate pressure settings (Adjustment range: 50 to 400 bar)
C...	LS pressure limitation for A and B side with a single shared pressure setting (Adjustment range: 50 to 400 bar)

Only in conjunction with

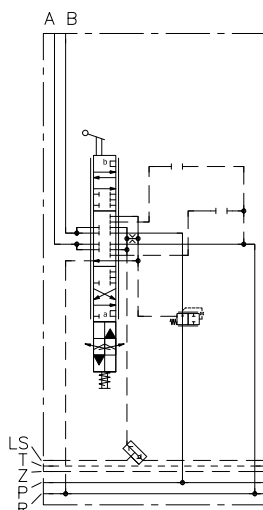
- Consumer ports coding 3, 4 (see also ["Table 10"](#)) or
- Consumer ports coding A (see also ["Table 10"](#)) and actuation coding E... (see also ["Table 22"](#))

Circuit symbols

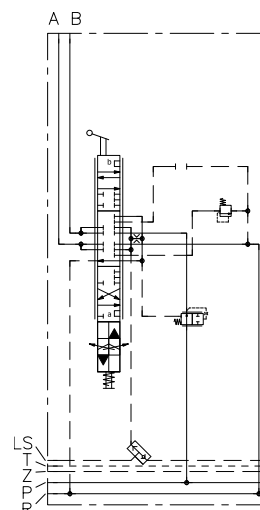
No designation



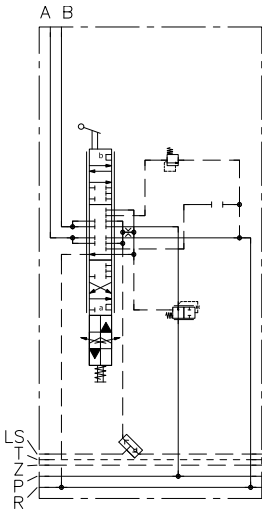
AB



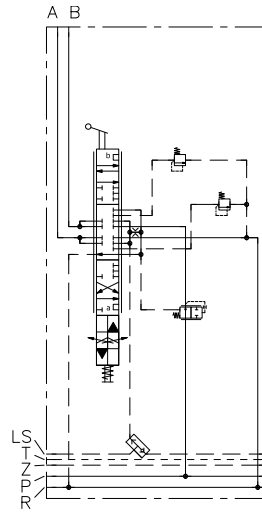
A...



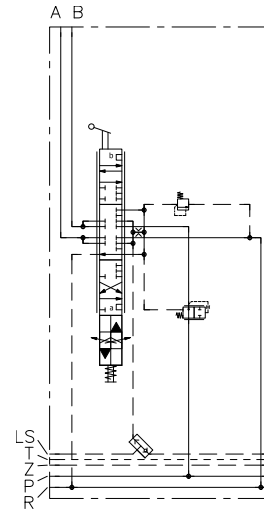
B...



A... B...



C...



i NOTE

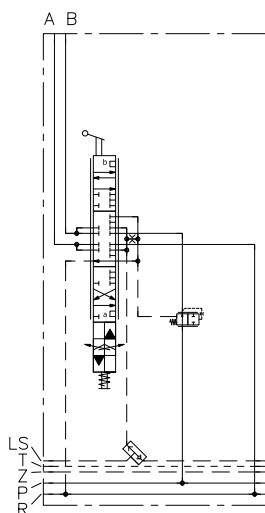
LS pressure limitation is only available in conjunction with a 2-way controller (see ["Table 11"](#)).

Table 17 Electric LS relief or LS pressure limitation

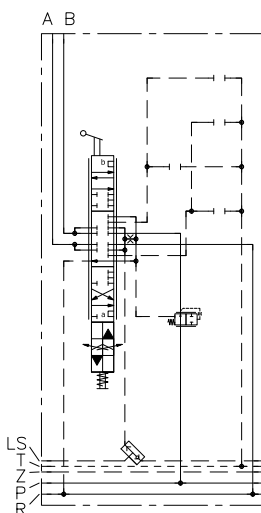
Coding	Description
No designation	Without LS relief or LS pressure limitation
F 0	Without electric LS relief or LS pressure limitation, but prepared for later conversion to coding F, FH, FP, FPH Only in conjunction with actuation coding E... (see also "Table 22")
F 1, F 2, F 3 FH 1, FH 2, FH 3	Electric LS relief (function deactivation) LS signal without load when unpowered. <ul style="list-style-type: none"> ▪ F1: A side only ▪ F2: B side only ▪ F3: A and B side separate ▪ FH 1, FH 2, FH 3: additionally with button for manual override Only in conjunction with actuation coding E... (see also "Table 22")
FP... FPH...	Electro-proportional LS pressure limitation with ascending characteristics <p>Pressure ranges for A and for B side:</p> <ul style="list-style-type: none"> ▪ 0 = sealed ▪ 1 = 20 to 150 bar ▪ 2 = 25 to 210 bar ▪ 3 = 35 to 320 bar ▪ 5 = 40 to 400 bar ▪ 7 = 50 to 420 bar <p>The first number applies to A side. The second number applies to B side. Order coding example: FP53</p> <ul style="list-style-type: none"> ▪ FPH...: additionally with button for manual override Only in conjunction with actuation coding E... (see also "Table 22")

Circuit symbols

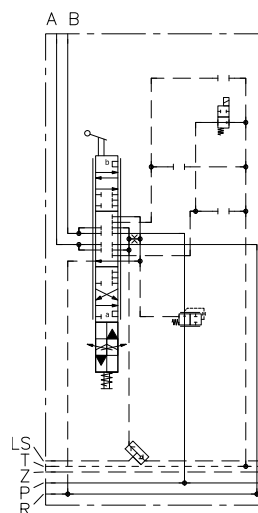
No designation



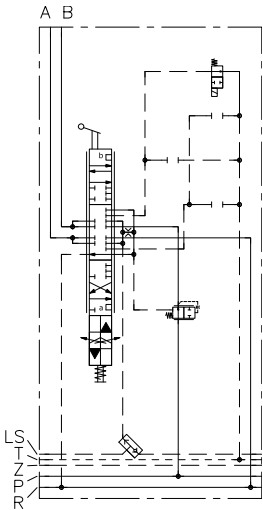
F 0



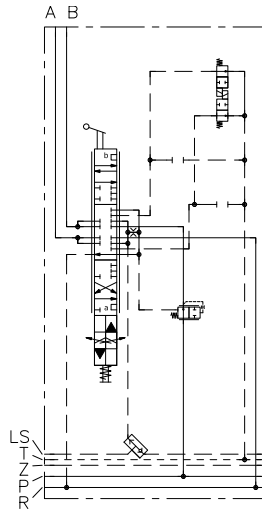
F 1, FH 1



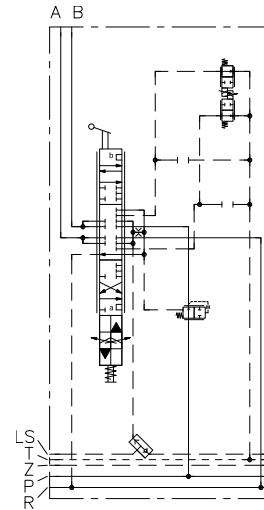
F 2, FH 2



F 3, FH 3



FP..., FPH...



i NOTE

Electric LS relief or LS pressure limitation is only available in conjunction with a 2-way controller (see "Table 11").

i NOTE

Even with LS relief, pressure in consumer gallery A or B cannot be reduced completely to 0 bar. The residual pressure in A or B ($p_{\min, A/B}$) results from

- a) control pressure in the 2-way controller ($\Delta p_{2\text{-way controller}}$),
- b) internal dynamic pressure in block (Δp_{Block}) and
- c) return pressure in T gallery (p_T).

$$p_{\min, A/B} = \Delta p_{2\text{-way controller}} + \Delta p_{\text{Block}} + p_T$$

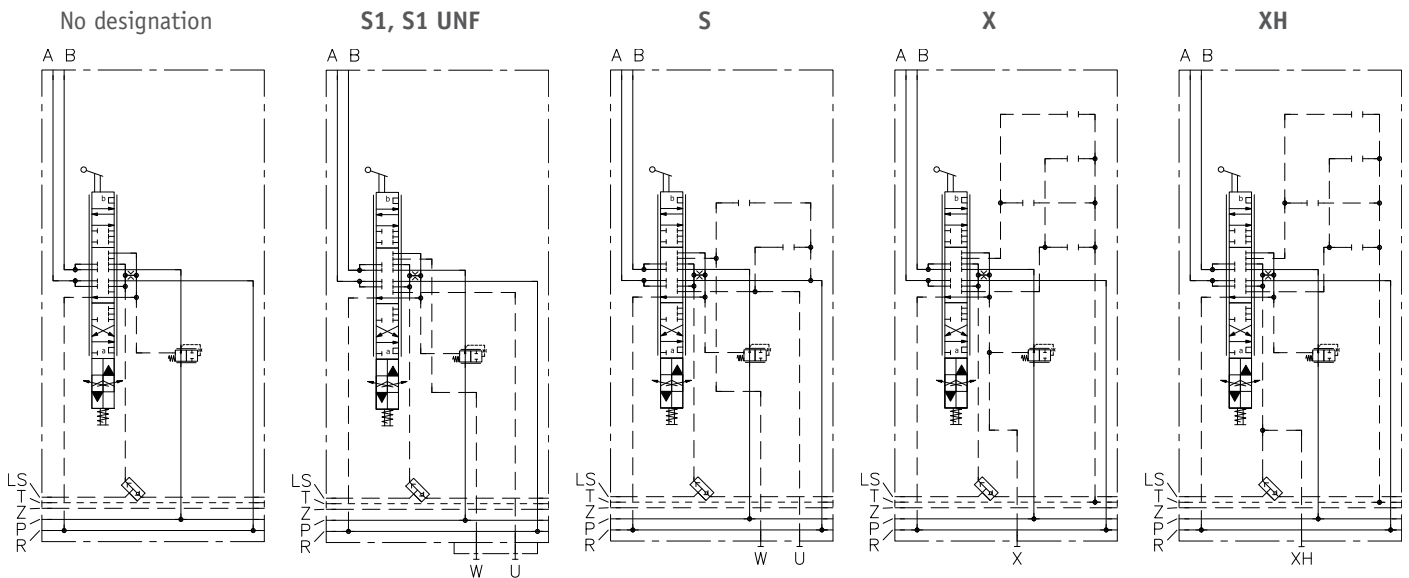
$\Delta p_{2\text{-way controller}}$: see "Table 12"

$\Delta p_{\text{Block}} = 10 \text{ bar}$ for coding F 1, F 2, F 3, FH 1, FH 2, FH 3, FP..., FPH...

Table 18 LS port for external limitation

Coding	Description
No designation	Without LS port for external limitation
S1 S1 UNF	<p>U and W port for connecting external pilot valve</p> <ul style="list-style-type: none"> ▪ U port = LS_A ▪ W port = LS_B <ul style="list-style-type: none"> ▪ S1: G 1/8 (ISO 228-1) (BSPP) ▪ S1 UNF: SAE-4 or 7/16-20 UNF-2B (SAE J 514) <p>Only in conjunction with</p> <ul style="list-style-type: none"> ▪ actuation coding E... (see also "Table 22")
S	<p>U and W port (G 1/8 (BSPP)) for connecting external pilot valve</p> <ul style="list-style-type: none"> ▪ U port = LS_A ▪ W port = LS_B <p>The ports are integrated directly in the spool block.</p> <p>Only in conjunction with</p> <ul style="list-style-type: none"> ▪ consumer ports coding 3, 4, A (see also "Table 10") ▪ LS pressure limitation coding AB, A..., B... or A... B... (see also "Table 16") ▪ actuation coding E... (see also "Table 22")
X	<p>X port for connecting external pilot valve</p> <ul style="list-style-type: none"> ▪ X port = LS_{A/B} <p>The port is integrated directly in the spool block.</p> <p>Only in conjunction with</p> <ul style="list-style-type: none"> ▪ consumer ports coding 3, UNF 3 (see also "Table 10") ▪ LS pressure limitation coding AB, A..., B... or A... B... (see also "Table 16") ▪ Electric LS relief or LS pressure limitation coding F 0, F..., FP... (see also "Table 17") ▪ Actuation coding E... (see also "Table 22") <p>Connection thread:</p> <ul style="list-style-type: none"> ▪ G 1/8 (ISO 228-1) (BSPP) for valve sections with consumer ports coding 3 ▪ SAE-4 or 7/16-20 UNF (SAE J 514) for valve sections with consumer port coding UNF 3
XH	<p>XH port (G 1/8 (BSPP)) for connecting external pilot valve</p> <ul style="list-style-type: none"> ▪ XH port = LS_{A/B} <p>Unlike with coding X, LS signal pick-up is upstream of the LS orifice. This makes a greater flow rate available for auxiliary functions (e.g. releasing a brake).</p> <p>The port is integrated directly in the spool block.</p> <p>Only in conjunction with</p> <ul style="list-style-type: none"> ▪ consumer ports coding 3, UNF 3 (see also "Table 10") ▪ LS pressure limitation coding AB, A..., B... or A... B... (see also "Table 16") ▪ Electric LS relief or LS pressure limitation coding F 0, F..., FP... (see also "Table 17") ▪ Actuation coding E... (see also "Table 22")

Circuit symbols



i NOTE
LS port for pressure limitation is only available in conjunction with a 2-way controller (see "Table 11").

i NOTE
Even with LS relief, pressure in consumer gallery A or B cannot be reduced completely to 0 bar. The residual pressure in A or B ($p_{\min, A/B}$) results from

- a) control pressure in the 2-way controller ($\Delta p_{2\text{-way controller}}$),
- b) internal dynamic pressure in block (Δp_{Block}) and
- c) return pressure (p_{reflux}).

$p_{\min, A/B} = \Delta p_{2\text{-way controller}} + \Delta p_{\text{Block}} + p_{\text{reflux}}$

$\Delta p_{2\text{-way controller}}$: see "Table 12"

Δp_{Block} for coding S, S 1 = 5 bar

Δp_{Block} for coding X = 10 bar

Table 19 LS orifice

Coding	Description
No designation	Standard version with \varnothing 0.8 mm orifice
7	Special version with \varnothing 0.7 mm orifice
9	Special version with \varnothing 0.9 mm orifice

Table 20 Shuttle valve

Coding	Description	Circuit symbol
No designation	Standard version	
W1	Special version without LS signal for own valve section Common applications for a pre-selector valve section together with closed centre LS valves (see also detailed description of coding 8 in "Table 11")	
W3	Special version without ball Only useful in manifold's final valve section in case the downstream LS gallery is not relieved by the end plate.	

Table 21 Additional functions

Coding	Description	Circuit symbol
D	<p>Valve sections with differential circuit (regeneration function)</p> <p>When in switching position a, the valve section links the A, B and P galleries. In this case, the A connects to the piston side and B to the cylinder's rod side.</p> <p>The differential circuit (regeneration function) allows reaching considerably greater cylinder extension speeds at the same pump flow rate. At the same time, however, the force available becomes lower because the pressure applied on the cylinder's piston and rod side is identical. This makes the differential function suitable only for dragging loads.</p> <p>Formula for calculating the required pump flow rate (Q_{pump}) as a function of desired flow rate for cylinder extension (Q_{piston}) and cylinder ratio:</p> $Q_{Pumpe} = Q_{Kolben} \cdot \left(1 - \frac{1}{\phi}\right)$ <p>Only in conjunction with</p> <ul style="list-style-type: none"> Consumer ports coding A (see also "Table 10") LS pressure limitation coding C... (see also "Table 16") Actuation coding E... (see also "Table 22") 	
FL	<p>Valve section with additional 1-, 2-, X- and Z-port facing ancillary block</p> <p>X port can be used, for example, for the intermediate plate /ZN BC... for pressure control (see also Chapter 2.3.3, "Intermediate plate").</p> <p>Z port can be used for ancillary block /4 BN...-EM. 3...-PMVPS 8... for pilot pressure supply for the PMVPS valve (see also Chapter 2.3.2, "Ancillary block").</p> <p>Only in conjunction with</p> <ul style="list-style-type: none"> Consumer ports coding A (see also "Table 10") LS pressure limitation coding AB, A..., B... or A... B... (see also "Table 16") Actuation coding E... (see also "Table 22") 	

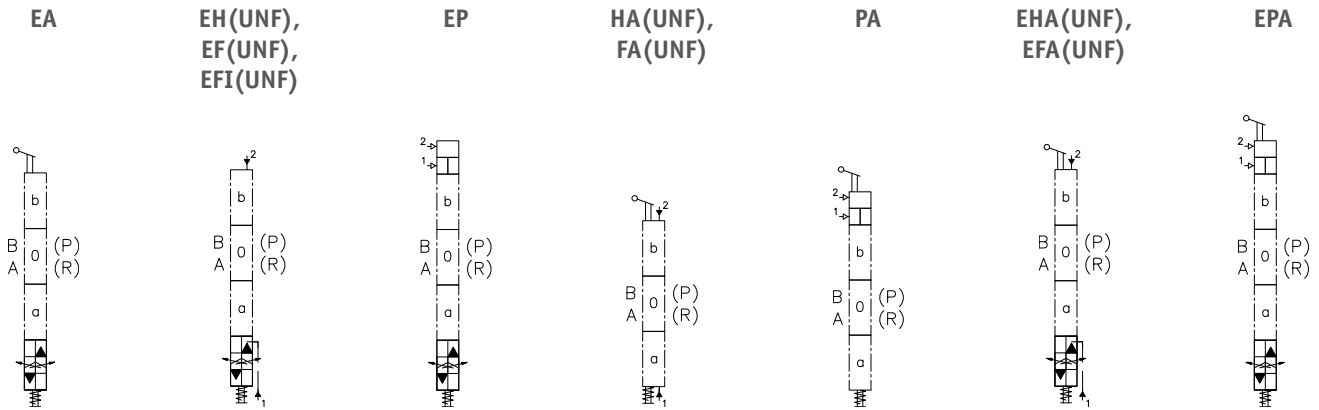
Table 22 Actuation

Coding	Description	Circuit symbol
Manual actuation		
A	Manual actuation with spring return	
AR	Manual actuation with 3 positions for switching positions 0, a and b. Cannot be combined with stroke limitation.	
D	<ul style="list-style-type: none"> ▪ AR: with spring return ▪ D: without spring return 	
C	Manual actuation, infinitely variable	
N	<p>Manual actuation in which the hand lever does not connect to the valve spool until it is pushed down.</p> <p>Combined with an electro-hydraulic actuation (coding EIN), individual stroke limitation is then only possible for manual actuation.</p> <p>Common applications: Safety functions that restrict speeds in setup or backup mode.</p>	
K K12	<p>Joystick actuation</p> <p>Combination manual actuation for two adjacent sections with shared dual-axis actuation.</p> <ul style="list-style-type: none"> ▪ K: with hand lever ▪ K12: with M12 thread and no hand lever, with weaker spring package and thus lower actuation torque, $p_{max} = 250$ bar 	
Electro-hydraulic actuation		
EI	Electro-hydraulic actuation without stroke limitation	
EM	Electro-hydraulic actuation with stroke limitation and measurement fitting	
ER	Electro-hydraulic actuation with 3 positions for switching positions 0, a and b. Cannot be combined with stroke limitation.	
EO	Prepared for electro-hydraulic actuation	

Coding	Description	Circuit symbol
CAN actuation		
EICAN EICANL EACAN EACANL	With CAN direct actuation as per D 7700 CAN <ul style="list-style-type: none"> ▪ CAN: CAN actuation with integrated displacement transducer for spool valve position control. The valve characteristics are linearised and hysteresis is minimised. ▪ CANL: CAN Lite actuation without integrated displacement transducer. Spool valve position is controlled but start and end point are calibrated. 	<div style="display: flex; flex-wrap: wrap;"> <div style="width: 50%;"> <p style="text-align: center;">EICAN</p> </div> <div style="width: 50%;"> <p style="text-align: center;">EICANL</p> </div> <div style="width: 50%;"> <p style="text-align: center;">EACAN</p> </div> <div style="width: 50%;"> <p style="text-align: center;">EACANL</p> </div> </div>
Hydraulic actuation		
H H UNF F F UNF FI FI UNF	Hydraulic actuation with pilot pressure connections on spring housing and lever housing <ul style="list-style-type: none"> ▪ H: Ports 1 and 2 perpendicular to valve axis, with stroke limitation Cannot be combined with ancillary blocks or intermediate plates mounting additional valves because port 1 would then collide with the additional valves. ▪ F, FI: Ports 1 and 2 parallel to valve axis F with stroke limitation. FI without stroke limitation. ▪ H, F, FI: G 1/4 (ISO 228-1) (BSPP) ▪ H UNF, F UNF, FI UNF: SAE-4 or 7/16-20 UNF-2B (SAE J 514) 	
EOZ EOZ UNF	Hydraulic actuation with separate pilot pressure connections beneath spring housing <ul style="list-style-type: none"> ▪ EOZ: G 1/8 (ISO 228-1) (BSPP) ▪ EOZ UNF: SAE-4 or 7/16-20 UNF-2B (SAE J 514) 	
Pneumatic actuation		
P	Pneumatic actuation with pilot pressure connections on lever housing. With stroke limitation. Ports: G 1/8 (ISO 228-1) (BSPP)	

The various actuation variants can be combined with one another. The following variants are possible:

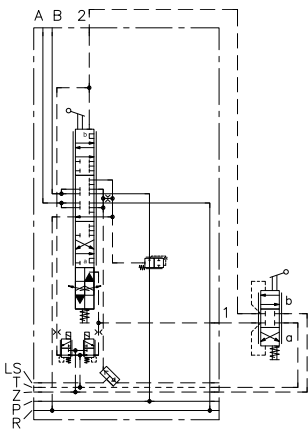
- Electric and manual: EA, EMA (UNF), EAR, EIN, EK, EK12, EOA, EOC, EOD, EOAR, EOK, EOK12
- Electric and hydraulic: EH (UNF), EF (UNF), EFI (UNF), EOH (UNF), EOF (UNF), EOFI (UNF)
- Electric and pneumatic: EP, EOP
- Hydraulic and manual: HA (UNF), FA (UNF)
- Pneumatic and manual: PA
- Electric, hydraulic and manual: EHA (UNF), EFA (UNF), Eoha (UNF), Eofa (UNF), Eoza (UNF), Eomza (UNF)
- Electric, pneumatic and manual: EPA, EOPA



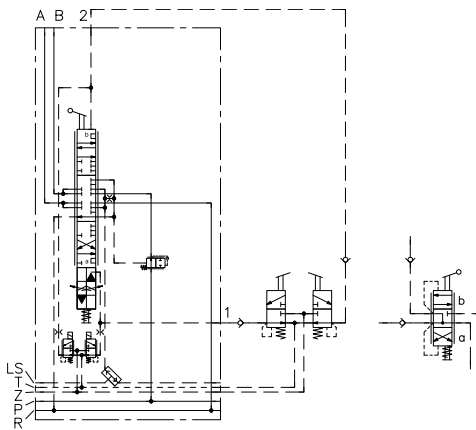
Note concerning actuation variants combining electric and hydraulic actuation (EH (UNF), EF (UNF), EFI (UNF), EHA (UNF) und EFA (UNF)):

Combination with hydraulic joysticks

with closed centre position



with open centre position



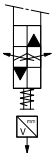
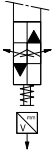




There are two $\varnothing 0.7$ mm orifices between the electro-hydraulic actuation's pilot valves and the pilot pressure connections 1 and 2. The control oil volume for the hydraulic joystick needs to be sufficiently large to compensate for bypass leakage through the orifice.

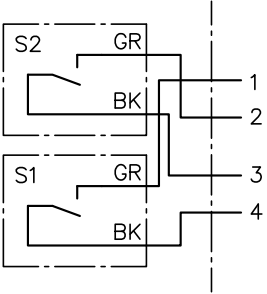

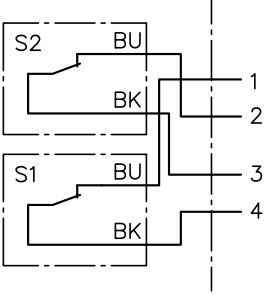

For joysticks with open centre position, pilot pressure connections 1 and 2 are connected to the tank when the joystick is in neutral position. Electro-hydraulic activation would then result in the entire control oil flow escaping that way, and no pressure would be built up to elevate the valve spool. For this reason, additional check valves need to be added to the control lines in this case.

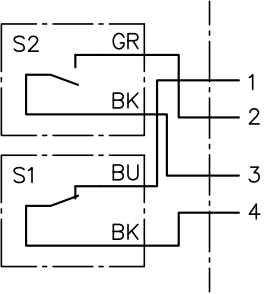



Table 23 Additional elements for actuation

Coding	Description
No designation	Standard version
1	Additional elements for manual actuation
2	<ul style="list-style-type: none"> ▪ 1: without lever arm
045	<ul style="list-style-type: none"> ▪ 2: with stub lever arm
212	<ul style="list-style-type: none"> ▪ 045: with regular lever arm, 45° elbow ▪ 212: stub lever arm, 12.5° elbow <p>Order coding example: SL 3-32 L 80/80/EA212-DT 24</p>
7	Additional descriptor for stronger or weaker spring package
8	<ul style="list-style-type: none"> ▪ 7: Actuation torque as for A actuation (neutral position: 2.3 Nm; final position: 3.4 Nm)
9	<ul style="list-style-type: none"> ▪ 8: Actuation torque as for E actuation (neutral position: 2.4 Nm; final position: 6.0 Nm) ▪ 9: Actuation torque as for H actuation (neutral position: 2.9 Nm; final position: 8.0 Nm) <p>Order coding example: SL 3-32 L 80/80/EA9-DT 24</p>
04, 05, 06, 08, 10, 12	Additional elements for electro-hydraulic actuation with damping
	Order coding example: SL 3-32 L 80/80//EI0808-DT 24
BE...	Additional elements for E0Z actuation with restrictor check valve type BE as per D 7555 B
	Order coding example: SL 3-32 L 80/80/E0Z BE0806
G	Spring housing with additional reinforcement flange to prevent damage and leaks in the spring housing for applications with high pressure peaks in reflux or T gallery.
	Order coding example: SL 3-32 L 80/80/EAG-DT 24

Table 24 Switching position monitoring, displacement transducer

Coding	Description	Circuit symbol
U	<p>Comparator for monitoring spool valve position.</p> <ul style="list-style-type: none"> ▪ In neutral position: A and B on ▪ P → A: A on, B off ▪ P → B: A off, B on ▪ Voltage U: 10 – 32 V DC <p>Connector types: X</p> <p>Order coding example: SL 3 A2 H16/16/EAU</p>	
WA WA-EX WA-M2FP	<p>Integrated displacement transducer (Hall-effect sensor) for valve position monitoring with analogue output signal.</p> <ul style="list-style-type: none"> ▪ WA-EX explosion-proof version ▪ WA-M2FP explosion-proof version <p>Connector types: AMP, DT, X, G, S, C</p> <p>Order coding example: SL 3 A2 H16/16/EAWA-AMP</p>	
V VA VB VC	<p>Contact switch for monitoring spool valve position.</p> <ul style="list-style-type: none"> ▪ V: Neutral position monitoring (signal upon activation without side distinction) ▪ VA: Direction detection direction A (signal upon activation toward A) ▪ VB: Direction detection direction B (signal upon activation toward B) ▪ VC: Direction detection direction A and B (signal upon separate activation toward A and B with side distinction) <p>Contact switch type V 4 NS® with lever AR 1 by BURGESS. Switch actuated in neutral position.</p> <p>Only in conjunction with</p> <ul style="list-style-type: none"> ▪ Actuation coding A, EA, EMA or HA (see also "Table 22") 	<p>V</p>  <p>VA</p>  <p>VB</p>  <p>VC</p> 

Coding	Description	Circuit symbol
VCHO VCHO2K	<p>Contact switch for monitoring spool valve position.</p> <p>Direction detection direction A (S2) and B (S1) as normally open contact (NO)</p>  <ul style="list-style-type: none"> ▪ VCHO: With connector, without cable ▪ VCHO2K: With connector and 2-m cable <p>Contact switch type V 4 N 4 Sk 2 ® with lever AR 1 and Hirschmann connector by BURGESS.</p> <p>Order coding example: SL 3 A2 H16/16/EAVCHO</p> <p>Only in conjunction with</p> <ul style="list-style-type: none"> ▪ Actuation coding A, EA, EMA or HA (see also "Table 22") 	
VCHC VCHC2K	<p>Contact switch for monitoring spool valve position.</p> <p>Direction detection direction A (S2) and B (S1) as normally closed contact (NC)</p>  <ul style="list-style-type: none"> ▪ VCHC: With connector, without cable ▪ VCHC2K: With connector and 2-m cable <p>Contact switch type V 4 N 4 Sk 2 ® with lever AR 1 and Hirschmann connector by BURGESS.</p> <p>Order coding example: SL 3 A2 H16/16/EAVCHC</p> <p>Only in conjunction with</p> <ul style="list-style-type: none"> ▪ Actuation coding A, EA, EMA or HA (see also "Table 22") 	

Coding	Description	Circuit symbol
<p>VCHOC VCHOC2K</p>	<p>Contact switch for monitoring spool valve position.</p> <p>Direction detection direction A (S2) as NO contact and B (S1) as NC contact</p>  <ul style="list-style-type: none"> ▪ VCHOC: With connector, without cable ▪ VCHOC2K: With connector and 2-m cable <p>Contact switch type V 4 N 4 Sk 2 ® with lever AR 1 and Hirschmann connector by BURGESS.</p> <p>Order coding example: SL 3 A2 H16/16/EAVCHOC</p> <p>Only in conjunction with</p> <ul style="list-style-type: none"> ▪ Actuation coding A, EA, EMA or HA (see also "Table 22") 	
<p>N N1</p>	<p>Proximity switch for monitoring valve neutral position without side distinction.</p> <ul style="list-style-type: none"> ▪ N: includes proximity switch type IFFM 08P/3701/02L® by BAUMER Electric GmbH ▪ N1: prepared for installation of proximity switch <p>Only in conjunction with</p> <ul style="list-style-type: none"> ▪ Actuation coding A or EA (see also "Table 22") 	<p>N</p>  <p>N1</p> 

A detailed description of the electric parameters is available in [Chapter 3.3.3, "Switching position monitoring, displacement transducer"](#)

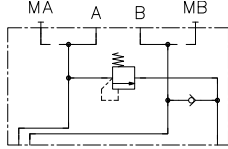
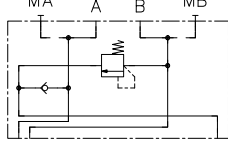
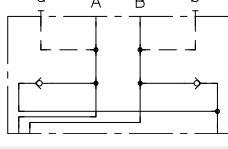
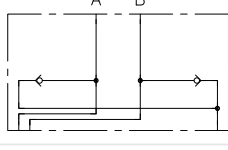
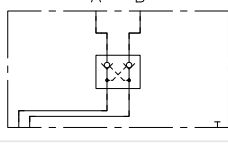
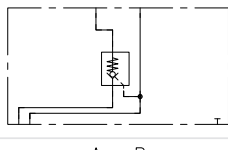
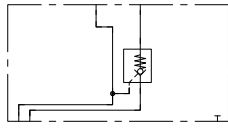
2.3.2 Ancillary block

Depending on their version, the ancillary blocks mount different kinds of additional valves (e.g. shock valves, releasable check valves, load-holding valves or electrically actuated 2/2-way directional seated valves). They can be flange-mounted onto either a valve section with flange surface (coding A as per ["Table 10: Consumer ports"](#)) or an intermediate plate ([Chapter 2.3.3, "Intermediate plate"](#)).

Ports A and B as per ISO 228-1 (BSPP) or SAE J 514 or JIS B 2351:

- /3: G 1/2
- /4: G 3/4
- /UNF 12: SAE-6 (9/16-18 UNF-2B)
- /UNF 2: SAE-8 (3/4-16 UNF-2B)
- /UNF 3: SAE-10 (7/8-14 UNF-2B)
- /JIS 3: JIS G 1/2

Coding	Description	Circuit symbol
/3 /4	No additional function	
/UNF 12 /UNF 2 /UNF 3 /JIS 3		
/3 AS... BS... /31 AS... BS... /4 AS... BS... /UNF 3 AS... BS...	Shock valves in A and B. (Adjustment range: 40 to 420 bar) The shock valves are each connected to their opposite side. Common applications: Pressure safeguard in hydraulic motors. <ul style="list-style-type: none"> ▪ /31 AS... BS...: permanently set ▪ /3 AS... BS..., /4 AS... BS..., /UNF 3 AS... BS...: Adjustable 	
/4 A...	Shock valves in A or B. (Adjustment range: 40 to 420 bar) The shock valves are each connected to the reflux.	
/4 B...		
/3 AN... BN... /31 AN... BN... /4 AN... BN... /44 AN... BN... /UNF 3 AN... BN...	Shock and anti-cavitation valves in A and B. (Adjustment range: 40 to 420 bar) The shock and anti-cavitation valves are each connected to the reflux. Common applications: Pressure safeguard in hydraulic cylinders. <ul style="list-style-type: none"> ▪ /31 AN... BN...: permanently set ▪ /3 AN... BN..., /4 AN... BN..., /UNF 3 AN... BN...: adjustable ▪ /44 AN... BN...: adjustable and additionally with internal link between both reflux sides, specially for large anti-cavitation flow rates 	

Coding	Description	Circuit symbol
/4 AN...	Shock valve in A and anti-cavitation valve in B. (Adjustment range: 40 to 420 bar)	
/4 BN...	Shock valve in B and anti-cavitation valve in A. (Adjustment range: 40 to 420 bar)	
/4 AN BN	Anti-cavitation valves in A and B.	
/UNF 3 AN BN		
/3 DRH /3 DRH VV /UNF 3 DRH /UNF 3 DRH VV	Releasable check valves (type DRH 3 as per D 6110). <ul style="list-style-type: none"> ▪ /3 DRH: releasable check valves in A and B ▪ /3 DRH A: releasable check valve in A ▪ /3 DRH B: releasable check valve in B 	
/3 DRH A	<ul style="list-style-type: none"> ▪ /3 DRH VV: releasable check valves with hydraulic release in A and B <p>Pressure required for releasing:</p> <ul style="list-style-type: none"> ▪ /3 DRH, /3 DRH A, /3 DRH B: 0.4-fold of checked pressure 	
/3 DRH B	<ul style="list-style-type: none"> ▪ /3 DRH VV: 0.1-fold of checked pressure 	

Coding
Description

/3 AL... BL...
/UNF 3 AL... BL...

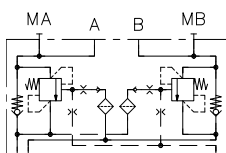
Load-holding valve (type LHT 30 as per [D 7918](#)).

- /3 AL... BL...: Load-holding valves in A and B
- /3 AL...: Load-holding valve in A
- /3 BL...: Load-holding valve in B

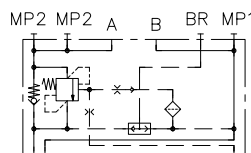
/3 AL...
/UNF 3 AL...

/3 BL...
/UNF 3 BL...

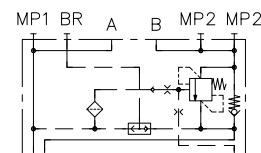
/3(/UNF 3) AL.. BL..



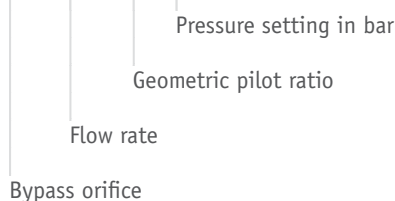
/3(/UNF 3) AL..



/3(/UNF 3) BL..

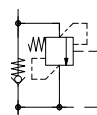

Order coding example:

/3 AL - 0 - A 7 /420

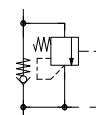


- Inflow orifice D1:
- Ø 0.5 mm
- Bypass orifice D2:
- 0 = sealed
- Ø 0.4/0.5/0.6/0.7/0.8 mm
- Geometric pilot ratio:
- 1:7 (coding 7)
- 1:∞ (coding 0)

Coding 7



Coding 0



For coding 0, load pressure has no effect, the load-holding valve is opened by the pilot pressure alone. In this case, the load-holding valve does not have an overpressure function.

Actual pilot ratio depends on bypass orifice:

Coding	0	4	5	6	7	8
Bypass orifice Ø (mm)	sealed	0.4	0.5	0.6	0.7	08
Geometric pilot ratio	1:7	1:7	1:7	1:7	1:7	1:7
Actual pilot ratio	1:7	1:5.0	1:3.5	1:2.3	1:1.3	1:0.9

Flow rate:

Coding	A	C	D	E	F
Q _{max} (lpm)	130	55	35	20	10

Coding

Description

/3 AC... BC...
/3 ACX... BCX...
/UNF 3 AC... BC...
/UNF 3 ACX... BCX...

Load-holding valves with relief (type LHTE 30 as per [D 7918](#)).

As type /3 AL... BL... but with additional spring cavity relief. By relieving the spring cavity, the load-holding valve's opening signal is unaffected by return pressure.

/3 AC...
/UNF 3 AC...

- /3 AC... BC...: Load-holding valves in A and B

- /3 AC...: Load-holding valve in A

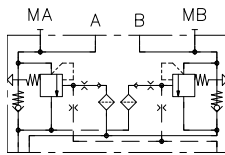
/3 BC...
/UNF 3 BC...

- /3 BC...: Load-holding valve in B

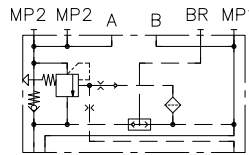
- AC or BC: Pressure setting adjustable from the outside using a tool

- ACX or BCX: permanently set

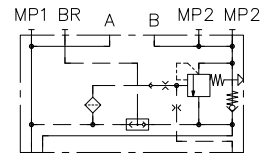
/3(/UNF 3) AC(X).. BC(X)..



/3(/UNF 3) AC(X)..

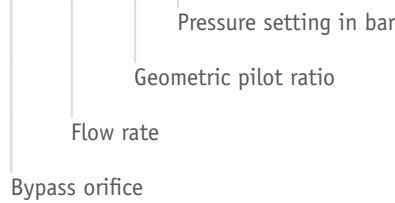


/3(/UNF 3) BC(X)..



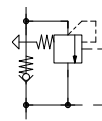
Order coding example:

/3 AC - 0 - A 7 /420

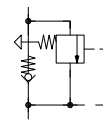


- Inflow orifice D1:
 - \varnothing 0.5 mm
- Bypass orifice D2:
 - 0 = sealed
 - \varnothing 0.4/0.5/0.6/0.7/0.8 mm
- Geometric pilot ratio:
 - 1:7 (coding 7)
 - 1: ∞ (coding 0)

Coding 7



Coding 0



For coding 0, load pressure has no effect, the load-holding valve is opened by the pilot pressure alone. In this case, the load-holding valve does not have an overpressure function.

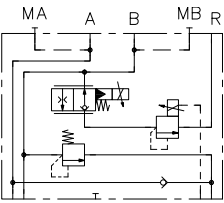
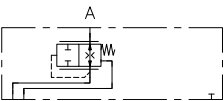
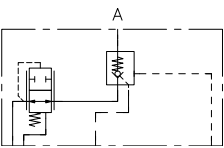
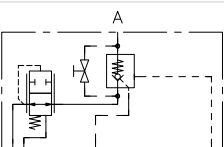
Actual pilot ratio depends on bypass orifice:

Coding	0	4	5	6	7	8
Bypass orifice \varnothing (mm)	sealed	0.4	0.5	0.6	0.7	08
Geometric pilot ratio	1:7	1:7	1:7	1:7	1:7	1:7
Actual pilot ratio	1:7	1:5.0	1:3.5	1:2.3	1:1.3	1:0.9

Flow rate:

Coding	A	C	D	E	F
Q_{max} (lpm)	130	55	35	20	10



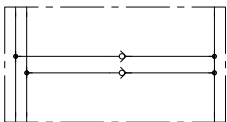
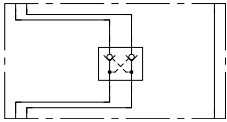
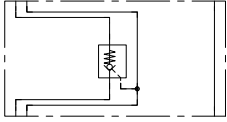
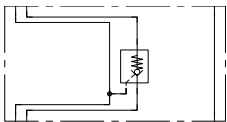
Coding	Description	Circuit symbol
/43 DFA	Differential function. The differential circuit (regeneration function) allows reaching considerably greater cylinder extension speeds at the same pump flow rate.	
/43 DFB	At the same time, however, the force available becomes lower because the pressure applied on the cylinder's piston and rod side is identical. This makes the differential function suitable only for dragging loads. <ul style="list-style-type: none"> ▪ /43 DFA: cylinder's piston side on A side, rod side on B side ▪ /43 DFB: cylinder's piston side on B side, rod side on A side Formula for calculating the required pump flow rate (Q_{pump}) as a function of desired flow rate for cylinder extension (Q_{piston}) and cylinder ratio: $Q_{Pumpe} = Q_{Kolben} \cdot \left(1 - \frac{1}{\phi}\right)$	
/3 SS /UNF 3 SS	Electrically actuated 2/2-way directional seated valve open in neutral position as check valve in A or B (type EM 32 S as per D 7490/1). $Q_{max} = 80 \text{ lpm}; p_{max} = 400 \text{ bar}$	
/3 SX /UNF 3 SX	<ul style="list-style-type: none"> ▪ /3 SS, /UNF 3 SS: Check valves in A and B ▪ /3 SX, /UNF 3 SX: Check valve in A ▪ /3 XS, /UNF 3 XS: Check valve in B Common applications: seat-tight sealing of consumers.	
/3 XS /UNF 3 XS		
/3 VV /UNF 3 VV	Electrically actuated 2/2-way directional seated valve closed in neutral position as check valve in A or B (type EM 32 V as per D 7490/1). $Q_{max} = 80 \text{ lpm}; p_{max} = 400 \text{ bar}$	
/3 VX /UNF 3 VX	<ul style="list-style-type: none"> ▪ /3 VV, /UNF 3 VV: Check valves in A and B ▪ /3 VX, /UNF 3 VX: Check valve in A ▪ /3 XV, /UNF 3 XV: Check valve in B Common applications: seat-tight sealing of consumers.	
/3 XV /UNF 3 XV		

Coding	Description	Circuit symbol
/4 BN...-EM 3...- PMVPS 8...	<p>Special version comprising</p> <ul style="list-style-type: none"> ▪ shock valve in B and anti-cavitation valve after A (coding BN..., adjustment range: 40 to 420 bar) ▪ electro-proportional pressure-limiting valve in B (type PMVPS 8... as per D 7485/1) ▪ electrically actuated 2/2-way directional seated valve (type EM 3... or EMP 3... as per D 7490/1) for activating or deactivating the PMVPS <p>$Q_{max} = 80 \text{ lpm}$; $p_{max} = 400 \text{ bar}$</p> <p>Common applications: electro-proportional pressure safeguard in hydraulic cylinders.</p> <p>Order coding example: /4 BN 250-EMP 31 V-PMVPS 8-44</p> <p>Only in conjunction with</p> <ul style="list-style-type: none"> ▪ spacer plate type ZPL 33/22 (see also Chapter 2.4, "Series intermediate plate") upstream of valve section on which the ancillary block is mounted ▪ Directional seated valve with additional function FL (see also "Table 21") 	
/3 .. DW /4 .. DW /UNF 3 .. DW	<p>Output controller for proportional lowering speed independent of load pressure in single-acting cylinder.</p> <p>Only possible in conjunction with circuit symbol N (see also "Table 14").</p> <p>Order coding example /32 DW: with standard 2-way controller and 2-way controller spring coding 2 as per "Table 11" and "Table 12"</p>	
/4.. HRP 4 /4.. HRP 4 V	<p>Output controller for proportional lowering speed independent of load pressure in single-acting cylinders combined with a releasable check valve for seat-tight load holding.</p> <p>Only possible in conjunction with circuit symbol NX (see also "Table 14").</p>	
/4.. HRP 4 /4.. HRP 4 V	<ul style="list-style-type: none"> ▪ V: releasable check valve with hydraulic release ▪ H: with drain screw <p>Order coding example /42 HRP 4: with standard 2-way controller and 2-way controller spring coding 2 as per "Table 11" and "Table 12"</p>	

2.3.3 Intermediate plate

Depending on their version, the intermediate plates mount different kinds of additional valves (e.g. anti-cavitation valves, releasable check valves, load-holding valves or electrically actuated 2/2-way directional seated valves).

They are installed between a valve section with flange surface (coding A as per ["Table 10: Consumer ports"](#)) and an ancillary block ([Chapter 2.3.2, "Ancillary block"](#)) and are often used to combine two or more additional valves with one another.

Coding	Description	Circuit symbol
/Z 40	Spacer plate, height 40 mm, for compensating height differences between adjacent valve sections.	
/Z 40 M /Z 40 M UNF	Spacer plate, height 40 mm, with measurement fittings A and B for compensating height differences between adjacent valve sections. <ul style="list-style-type: none"> ▪ /Z 40 M: G 1/4 (ISO 228-1) (BSPP) ▪ /Z 40 M UNF: SAE-4 or 7/16-20 UNF-2B (SAE J 514) 	
/Z AN BN	Anti-cavitation valves in A and B.	
/ZDRH /ZDRH VV /ZDRH 5 VV	Releasable check valves (type DRH 3 as per D 6110). <ul style="list-style-type: none"> ▪ /ZDRH: releasable check valves in A and B ▪ /ZDRH .. A: releasable check valve in A ▪ /ZDRH .. B: releasable check valve in B 	
/ZDRH A /ZDRH VV A /ZDRH 5 VV A	<ul style="list-style-type: none"> ▪ VV: releasable check valves with hydraulic release ▪ 5 VV: with heavy-duty spring and hydraulic release 	
/ZDRH B /ZDRH VV B /ZDRH 5 VV B	<p>Pressure required for releasing:</p> <ul style="list-style-type: none"> ▪ /ZDRH, /ZDRH A, /ZDRH B: 0.4-fold of checked pressure ▪ /Z DRH VV, /Z DRH VV A, /Z DRH VV B, /Z DRH 5 VV, /Z DRH 5 VV A, /Z DRH 5 VV B: 0.1-fold of checked pressure 	

Coding

Description

/Z AL... BL...

Load-holding valve (type LHT 3 as per [D 7918](#)).

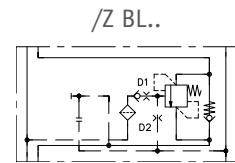
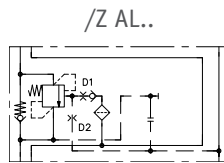
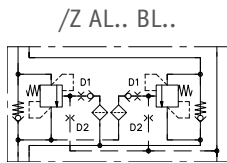
/Z AL...

- /Z AL... BL...: Load-holding valves in A and B

/Z BL...

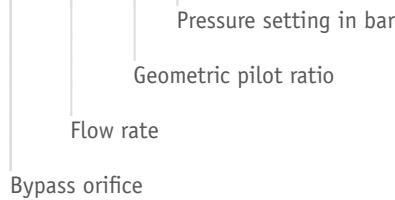
- /Z AL...: Load-holding valve in A

- /Z BL...: Load-holding valve in B



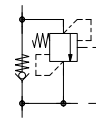
Order coding example:

/ZAL - 0 - A 7 /420

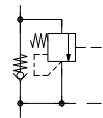


- Inflow orifice D1:
 - \varnothing 0.5 mm
- Bypass orifice D2:
 - 0 = sealed
 - \varnothing 0.4/0.5/0.6/0.7/0.8 mm
- Geometric pilot ratio:
 - 1:7 (coding 7)
 - 1: ∞ (coding 0)

Coding 7



Coding 0



For coding 0, load pressure has no effect, the load-holding valve is opened by the pilot pressure alone. In this case, the load-holding valve does not have an overpressure function.

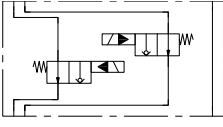
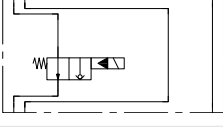
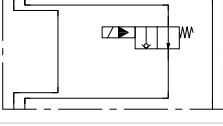
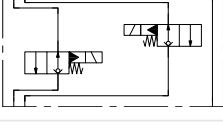
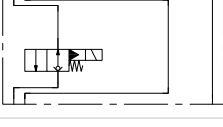
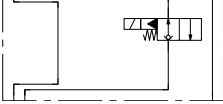
Actual pilot ratio depends on bypass orifice:

Coding	0	4	5	6	7	8
Bypass orifice \varnothing (mm)	sealed	0.4	0.5	0.6	0.7	08
Geometric pilot ratio	1:7	1:7	1:7	1:7	1:7	1:7
Actual pilot ratio	1:7	1:5.0	1:3.5	1:2.3	1:1.3	1:0.9

Flow rate:

Coding	A	C	D	E	F
Q_{max} (lpm)	130	55	35	20	10

Coding	Description	Circuit symbol
/Z AL... - BN...	Combination of load-holding valve on one side and shock and anti-cavitation valve on the other side. <ul style="list-style-type: none"> ▪ /Z AL... - BN...: Load-holding valve in A and shock anti-cavitation valve in B ▪ /Z BL... - AN...: Load-holding valve in B and shock anti-cavitation valve in A 	
/Z BL... - AN...	Load-holding valve: Description and order coding example see /Z AL... BL... Shock and anti-cavitation valve: each connected to the reflux. (Adjustment range: 40 to 420 bar)	
/ZN BC...	Pressure reduction in B. $Q_{max} = 25 \text{ lpm}$; $p_{max} = 240 \text{ bar}$ The intermediate plate comprises a pilot valve for adjusting the pressure to be controlled at port B (adjustment range: 40 to 200 bar) and a 3-way controller (adjustment range: 15 to 30 bar). The pilot valve acts through the LS gallery on the 2-way controller in the valve section to control inflow pressure in B. The pilot valve at the same time also acts on the 3-way controller. The latter functions as a shock valve and ensures that external forces cannot raise pressure in B beyond the value set. Order coding example: /ZN BC 250-20 Typical applications: Contact pressure control, press force control or tensile force control Only in conjunction with directional valve sections with additional function coding FL (see also "Table 21")	
/ZDR	Electrically actuated 2/2-way directional seated valve as short-circuit valve. $Q_{max} = 25 \text{ lpm}$ <ul style="list-style-type: none"> ▪ /ZDR: closed in neutral position (type BV 1 R) ▪ /ZDR: open in neutral position (type BV 1 S) 	
/ZDS	Cannot be combined with ancillary block types / (UNF) 3 AS... BS..., /4 AS... BS..., /4 B..., / (UNF) 3 AN... BN..., /4 AN... BN..., /44 AN... BN..., /4 BN..., / (UNF) 3 AL... BL..., / (UNF) 3 BL..., / (UNF) 3 AC... BC..., / (UNF) 3 BC..., / (UNF) 3 SS, / (UNF) 3 XS, / (UNF) 3 VV, / (UNF) 3 XV or /4 BN...-EM 3...-PMVPS 8...	

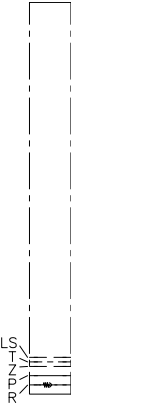
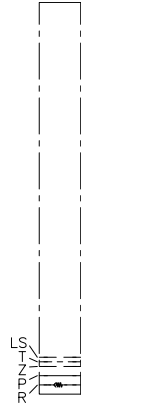
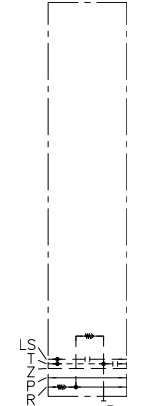

Coding	Description	Circuit symbol
/ZSS	<p>Electrically actuated 2/2-way directional seated valve open in neutral position as check valve in A or B (EM 32 S as per D 7490/1).</p> <p>$Q_{max} = 80 \text{ lpm}$; $p_{max} = 400 \text{ bar}$</p> <ul style="list-style-type: none"> ▪ /ZSS: Check valves in A and B 	
/ZSX	<ul style="list-style-type: none"> ▪ /ZSX: Check valve in A ▪ /ZXS: Check valve in B 	
/ZXS	<p>Common applications: seat-tight sealing of consumers.</p>	
/ZVV	<p>Electrically actuated 2/2-way directional seated valve closed in neutral position as check valve in A or B (EM 32 V as per D 7490/1).</p> <p>$Q_{max} = 80 \text{ lpm}$; $p_{max} = 400 \text{ bar}$</p> <ul style="list-style-type: none"> ▪ /ZVV: Check valves in A and B 	
/ZVX	<ul style="list-style-type: none"> ▪ /ZVX: Check valve in A ▪ /ZXV: Check valve in B 	
/ZXV	<p>Common applications: seat-tight sealing of consumers.</p>	

2.4 Series intermediate plate

Series intermediate plates can be placed into a manifold in any position instead of a regular valve section.

Depending on the version, they mount different kinds of additional valves (e.g. as P-gallery shut-offs, for controlling a second pressure stage or for supplying single-acting consumers). They can also act as spacer plates or transition plates to other PSL sizes or another valve series.

Coding	Description
ZPL 33/5 ZPL 33/15 ZPL 33/22 ZPL 33	Spacer plate. <ul style="list-style-type: none"> ▪ ZPL 33/5: Width 5 mm ▪ ZPL 33/15: Width 15 mm ▪ ZPL 33/22: Width 22 mm ▪ ZPL 33: Width 49.5 mm ZPL 33/5(15.22) ZPL 33
ZPL 32 ZPL 3-SWS 2 ZPL 35 P4R5 .	Transition plate to other PSL sizes or other valve series. <ul style="list-style-type: none"> ▪ ZPL 32: Transition to PSL 2 as per D 7700-2 ▪ ZPL 3-SWS 2: Transition to SWS as per D 7951 ▪ ZPL 35 P4R5 .: Transition to PSL 5 as per D 7700-5 <ul style="list-style-type: none"> - Port P: G 3/4 (ISO 228-1) (BSPP) - Port R: G 1 (ISO 228-1) (BSPP) - Additional without designation, 1 or 2 as per "Table 6" Order coding example: ZPL 35 P4R5 1 ZPL 32 ZPL 3-SWS 2 ZPL 35 P4R5 .

Coding	Description
<p>ZPL 33/15/R1 ZPL 33/15/R2 ZPL 33/20/RB R1 XTL</p>	<p>Check valve in R gallery.</p> <ul style="list-style-type: none"> ▪ ZPL 33/15/R1: Locking direction from connection block toward end plate ▪ ZPL 33/15/R2: Locking direction from end plate toward connection block ▪ ZPL 33/20/RB R1 XTL: <ul style="list-style-type: none"> - Locking direction from connection block toward end plate - Shut-off for LS and T gallery as well as internal link between LS, T and R2 <div style="display: flex; justify-content: space-around; margin-top: 20px;"> <div style="text-align: center;"> <p>ZPL 33/15/R1</p>  </div> <div style="text-align: center;"> <p>ZPL 33/15/R2</p>  </div> <div style="text-align: center;"> <p>ZPL 33/20/RB R1 XTL</p>  </div> </div>
<p>ZPL 3-Z 3</p>	<p>P port for second pump circuit.</p> <ul style="list-style-type: none"> - Port P2: G 1/2 (ISO 228-1) (BSPP) <div style="margin-top: 20px;">  </div>

Coding
Description
ZPL 3 P/...

P pressure limitation for all downstream valve sections.
(Adjustment range: 40 to 420 bar)

There is a pilot-controlled pressure reducing valve in the P gallery consisting of a 2-way controller and a pressure-limiting valve. The pressure reducing valve limits the P pressure for downstream valve sections to a set value.

Order coding example: ZPL 3 P/250

Typical applications:

- Realising two pressure levels in a single manifold
- Pressure limitation for valve sections that have no 2-way controller

i NOTE

Only possible in conjunction with PSL connection block with 3-way controller spring coding H (see also "[Table 4](#)") or with PSV connection block. The downstream valve sections cannot have a 2-way controller spring coding 5 or 7 (see also "[Table 12](#)").

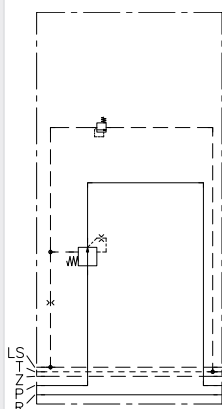
i NOTE

When using a the series intermediate plate, there is an additional pressure drop in the P gallery that can lead to the downstream sections no longer reaching nominal flow.

Nominal flow undercut depends on

- a) control pressure difference of the 3-way controller (PSL) or variable pump's pump controller (PSV),
- b) position of the valve sections in the manifold and
- c) flow rate through the intermediate plate.

Nominal flow undercut can reach up to 30% of Q_{nominal} , see also "[Table 15: Flow rate](#)".



Coding

ZPL 3 S/H
ZPL 3 V/H
ZPL 3 S/E
ZPL 3 V/E

Description

P-gallery shut-off.

There is a pilot-controlled 2/2-way directional valve for securely sealing the P gallery and all downstream valve sections against the pump.

- **ZPL 3 S:** P gallery open when not actuated
- **ZPL 3 V:** P gallery sealed when not actuated
- **/H:** hydraulic actuation through port S
- **/E:** electro-hydraulic actuation by means of a 3/2 directional seated valve (type WN 1 H as per [D 7470 A/1](#))

- Port S: G 1/4 (ISO 228-1) (BSPP)

Common applications:
Second switch-off method for safety functions.

i NOTE
Only possible in conjunction with PSL connection block with 3-way controller spring coding H (see also "Table 4") or with PSV connection block.

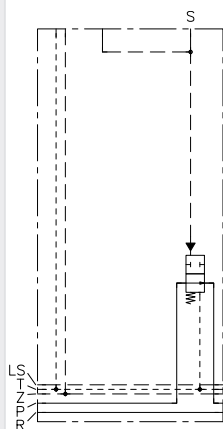
i NOTE
When using a P-gallery shut-off, there is an additional pressure drop in the P gallery that can lead to the downstream sections no longer reaching nominal flow.

Nominal flow undercut depends on

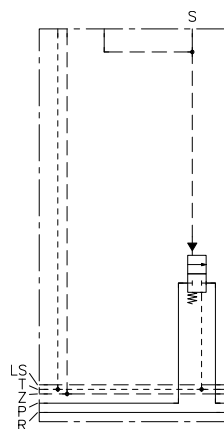
- a) control pressure difference of the 3-way controller (PSL) or variable pump's pump controller (PSV),
- b) position of the valve sections in the manifold and
- c) flow rate through the P-gallery shut-off.

Nominal flow undercut can reach up to 30% of Q_{nominal} , see also "Table 15: Flow rate".

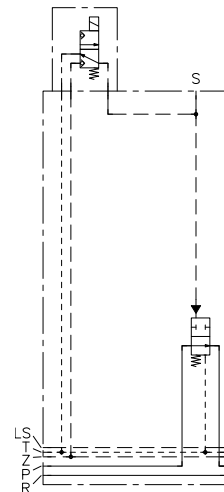
ZPL 3 S/H



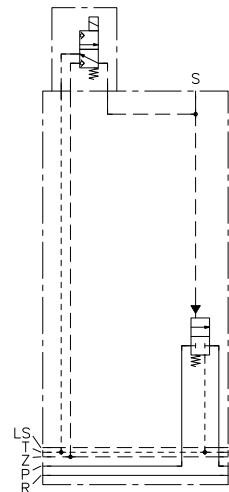
ZPL 3 V/H



ZPL 3 S/E



ZPL 3 V/E



Coding
Description
ZPL 3 D
ZPL 3 DS

Intermediate plate for activating/deactivating a second speed for all downstream valve sections.

There is an adjustable throttle in the P gallery for limiting the flow rate supplied to the downstream valve sections. The throttle can be bypassed through an electrically actuated 2/2 directional seated valve.

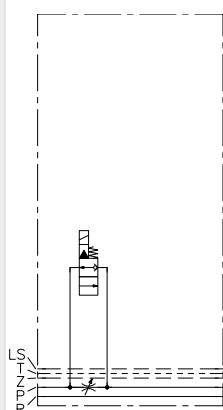
- **ZPL 3 D:** Reduced speed when unpowered (EM 21 D as per [D 7490/1](#)).
- **ZPL 3 DS:** Reduced speed when powered (EM 21 DS as per [D 7490/1](#)).

 $Q_{\max, \text{ pump}} = 60 \text{ lpm}; Q_{\text{reduced}} = 0 \dots 20 \text{ lpm}$

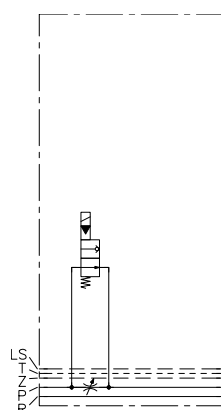
Common applications:

Speed reduction for setup mode or backup mode or other specific operating states (e.g. transporting passengers).

ZPL 3 D



ZPL 3 DS


ZPL 3 D/...
ZPL 3 DS/...

Like ZPL 3 D and ZPL DS, but additionally with pressure-limiting valve to limit maximum pressure when throttle is fully open.

(Adjustment range: 40 to 420 bar)

This results in two operating modes:

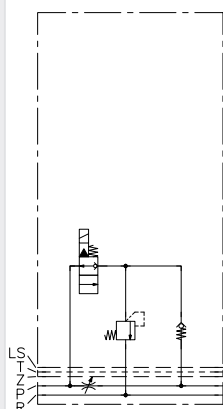
- a) reduced speed at high pressure
- b) reduced pressure at high speed

- **ZPL D/...:** Reduced speed when unpowered (EM 21 D as per [D 7490/1](#)).
- **ZPL 3 DS/...:** Reduced speed when powered (EM 21 DS as per [D 7490/1](#)).

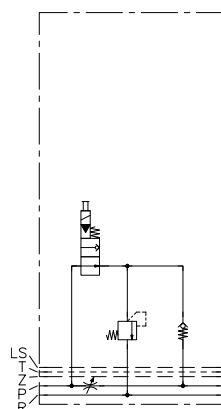
Common applications:

Load increase at reduced speed for loading cranes

ZPL 3 D/...



ZPL 3 DS/...



Coding

Description

ZPL 3 VQ...

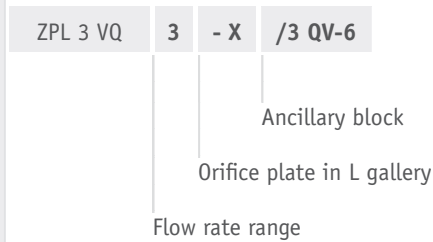
Priority flow divider.

The priority flow divider sets a certain flow rate for port L for supplying one or more external consumers. The remaining flow is available to the downstream valve sections.

The flow rate diverted to port L can be either

- a) permanently set using an orifice plate,
- b) controlled by an external signal to port LLS or
- c) adjustable using an electro-proportional 2/2-way directional valve.

Order coding example:



Flow rate range:

- **1:** $Q_L \leq 20$ lpm
- **2:** $Q_L = 21 \dots 50$ lpm
- **3:** $Q_L > 50$ lpm

Orifice plate in L gallery:

- **X:** without orifice plate
- **2:** with $\varnothing 2.0$ mm orifice plate, $Q_L = 8$ lpm
- **3:** with $\varnothing 3.0$ mm orifice plate, $Q_L = 18$ lpm
- **4:** with $\varnothing 4.0$ mm orifice plate, $Q_L = 30$ lpm
- **5:** with $\varnothing 5.0$ mm orifice plate, $Q_L = 40$ lpm
- **6:** with $\varnothing 6.0$ mm orifice plate, $Q_L = 60$ lpm

Ancillary block:

Coding

Description

/3 Q
/UNF 3 Q

Ancillary block without additional functions. Either for maintaining a constant flow rate through port L using a fixed orifice plate (coding 2, 3, 4, 5, 6) or for feeding a load signal through port LLS (coding X).

/3 QV
/3 QV 80
/3 QS
/UNF 3 QV
/UNF 3 QV 80
/UNF 3 QS

Ancillary block with electro-proportional 2/2-way directional valve type EMP 31 as per [D 7490/1](#) for controlling variable flow rate to port L.

- **QV:** EMP 31 V
- **QV 80:** EMP 31 V 80 V
- **QS:** EMP 31 S

only without orifice plate in L gallery (coding X)

Optionally with additional damping orifice in ancillary block

- **no designation:** Standard version without damping orifice
- **5:** $\varnothing 0.5$ mm
- **6:** $\varnothing 0.6$ mm
- **7:** $\varnothing 0.7$ mm

Order coding example: /3 QV-6

Coding /3:

- Port L: G 1/2 (ISO 228-1) (BSPP)
- Port LLS: G 1/4 (ISO 228-1) (BSPP)

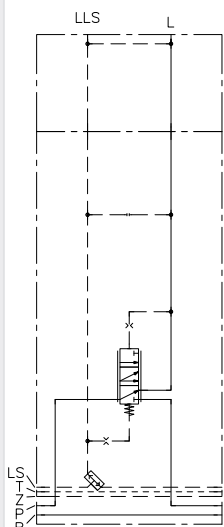
Coding /UNF 3:

- Port L: SAE-10 or 7/8-14 UN-2B (SAE J 514)
- Port LLS: SAE-4 or 7/16-20 UNF-2B (SAE J 514)

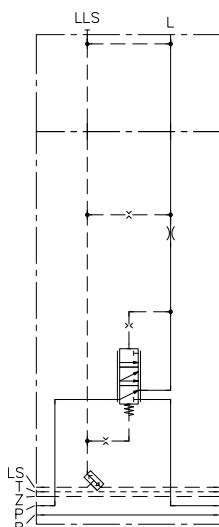
Coding

Description

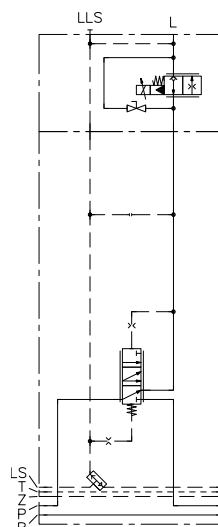
ZPL 3 VQ .-X/3 Q



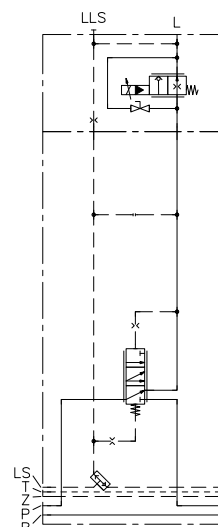
ZPL 3 VQ .-./3 Q



ZPL 3 VQ .-X/3 QV



ZPL 3 VQ .-X/3 QS-6



ZPL 3 TX...
ZPL 3 TV...

Pressure reduction for external consumer.
(Adjustment range: 40 - 420 barr)

There is a pilot-controlled pressure reducing valve on the intermediate plate consisting of a 2-way controller and a pressure-limiting valve. The pressure reducing valve sets a constant flow rate for port A for supplying one or more external consumers.

- **ZPL 3 TX:** with continuous P gallery
- **ZPL 3 TV:** P1 port for second pump circuit

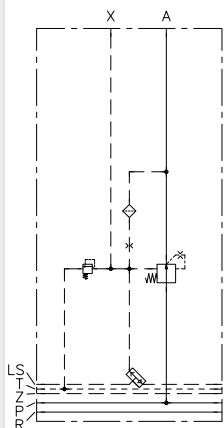
Various orifice variants are available for damping the 2-way controller:

- **5:** Ø 0.5 mm
- **6:** Ø 0.6 mm
- **7:** Ø 0.7 mm
- **8:** Ø 0.8 mm
- **9:** Ø 0.9 mm

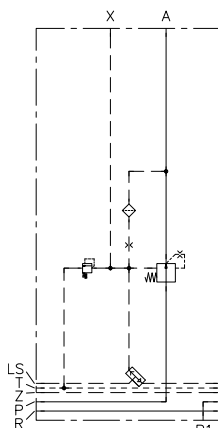
Order coding example: ZPL 3 TV 7/250

- Port A: G 1/2 (ISO 228-1) (BSPP)
- Port P1: G 1/2 (ISO 228-1) (BSPP)
- Connection X: G 1/4 (ISO 228-1) (BSPP)

ZPL 3 TX



ZPL 3 TV



Coding

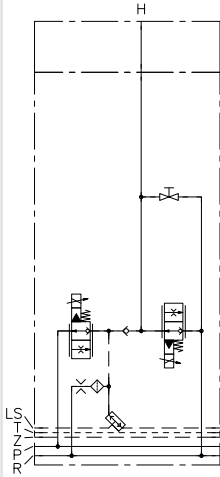
Description

A1 RR PVPV/5

Intermediate plate with two electro-proportional 2/2-way directional seated valves (type EMP 41 V as per [D 7490/1](#)) for extending and retracting single-acting cylinders.

$Q_{max} = 160 \text{ lpm}$; $p_{max} = 350 \text{ bar}$

- Port H: G 1 (ISO 228-1) (BSPP)



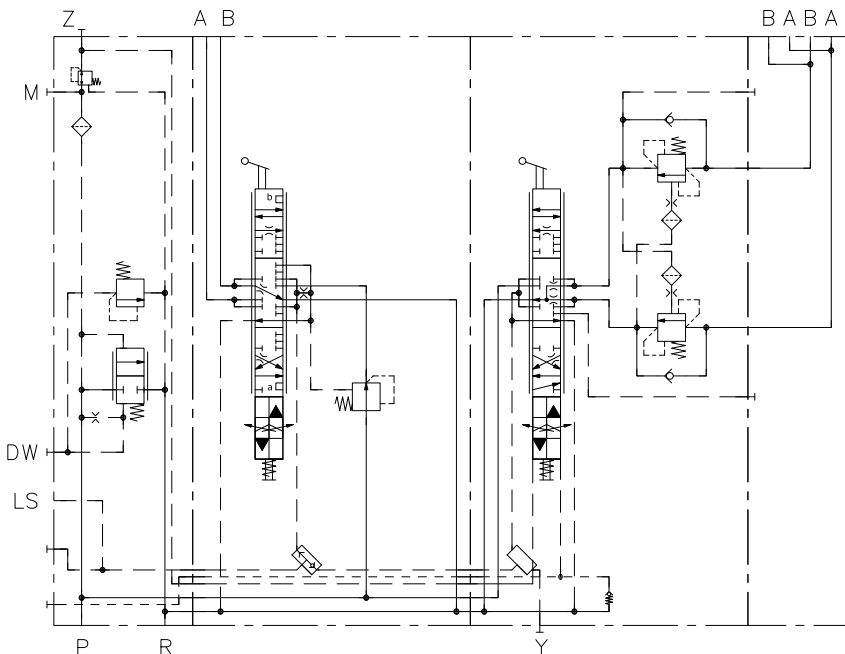
2.5 Valve section with integrated load-holding valves

This special valve section features directly integrated load-holding valves. It can only be used as a manifold's final valve section and is combined with specially designed end plates. Optionally, a differential circuit (regeneration function) is possible.

Common applications: Skip lorries

Example schematic:

PSV 551/275 - 3 - 32 B 40/63/EAB
 - F1 O 80/80 - 0 - B 6/280 - 0 - C 6/280/EA
 - EF 30 - G 24



Order coding example:

SL 3	- F1	H 80/80	- 0 - B 6/350	- 0 - C 6/300	/EA	- EF 30
						End plate "Table 33"
						Actuation <ul style="list-style-type: none">▪ "Table 22 Actuation"▪ "Table 23 Additional elements for actuation"
						Load-holding valve on side B Section configuration load-holding valve
						Load-holding valve on side A Section configuration load-holding valve
						Valve spool <ul style="list-style-type: none">▪ "Table 31 Circuit symbol"▪ "Table 32 Flow rate"
						Valve section "Table 30"

Table 30 Valve section

Coding	Description
F1	Standard version.
F5	Version with Y port and shuttle valve for connecting a downstream manifold's LS signal.

Circuit symbols

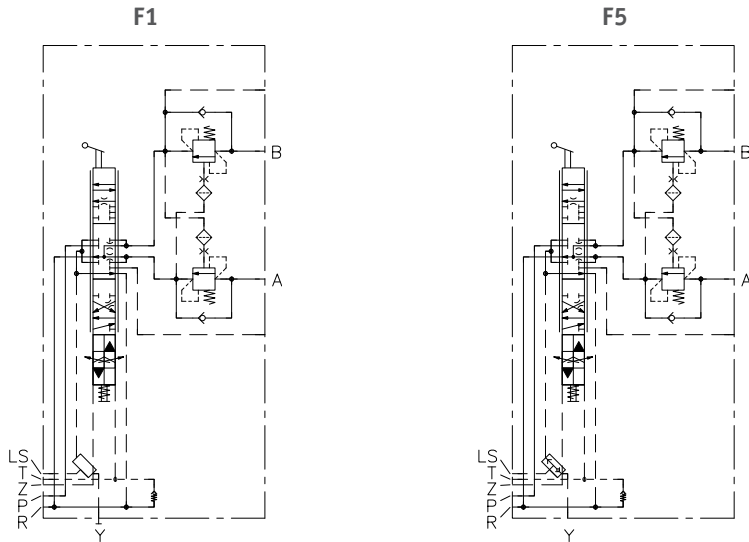


Table 31 Circuit symbol

Coding	Description	Circuit symbol
H HW	Standard spool valve with low return pressure. <ul style="list-style-type: none"> HW: Special version with broad fitting tolerance. 	
O OW	Standard spool valve with constant return pressure 20 bar. <ul style="list-style-type: none"> OW: Special version with broad fitting tolerance. 	
HV	Special spool valve for differential circuit together with end plate type EF 31. <p>Just before reaching maximum spool valve elevation in direction a, the HV spool valve activates the differential circuit in end plate EF 31.</p>	

Table 32 Flow rate
Flow rate coding (Q_{nominal})

3	6	10	16	25	40	63	80
---	---	----	----	----	----	----	----

The valve section does not include a 2-way controller, which means that flow rate is dependent on pressure difference between pump pressure (p_{pump}) and consumer pressure ($p_{A/B}$). It can be calculated using the following equation:

$$Q_{A/B} = Q_{\text{Nenn}} \cdot \sqrt{0.2 \cdot \Delta p_{\text{Regler}}}$$

$Q_{A/B}$ = flow rate to port A or B

Q_{nominal} = nominal flow rate of valve spool at pressure difference of 6 bar

$\Delta p_{\text{controller}}$ = control pressure difference of the 3-way controller (PSL) or variable pump's pump controller (PSV)

Example:

- PSL connection block, standard 3-way controller spring (9 bar)

$$Q_{A/B} = 80 \text{ l/min} \cdot \sqrt{0.2 \cdot 9} = 107 \text{ l/min}$$

- PSL connection block, 3-way controller with heavy-duty spring (14 bar)

$$Q_{A/B} = 80 \text{ l/min} \cdot \sqrt{0.2 \cdot 14} = 134 \text{ l/min}$$

- PSV connection block, pump controller with 25 bar standby pressure

$$Q_{A/B} = 80 \text{ l/min} \cdot \sqrt{0.2 \cdot 25} = 179 \text{ l/min}$$

i NOTE

The calculate values are rough reference values! They apply to the highest-load consumer. If multiple consumers are being actuated in parallel, the pressure difference may be considerably greater at the lower-load consumers.


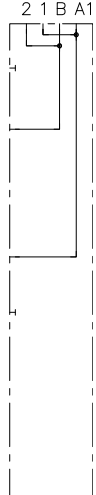
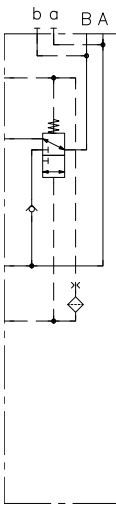
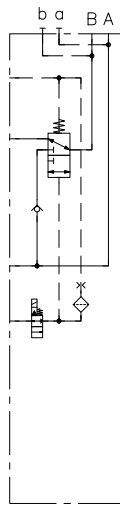
Configuration load-holding valve (example: O-B 6/350)

- LHT 50 as per [D 7918](#)
- Inflow orifice D1: \varnothing 0.5 mm
- Bypass orifice D2: sealed (coding 0)
- Flow rate:

Coding	A	B	C	D	E	F
Q_{max} (lpm)	250	200	150	100	50	25

- Pilot ratio: 1:6 (coding 6)
- Pressure setting in bar

Table 33 End plate

Coding	Description	Circuit symbol	
<p>EF 30 EF 41 EF 42</p>	<p>Standard end plate for valve sections with integrated load-holding valves with four consumer ports each.</p> <ul style="list-style-type: none"> ▪ EF 30: 4x G 1/2 (BSPP) ▪ EF 41: 2x G 3/4 and 2x G 1/4 (BSPP) ▪ EF 42: 2x G 3/4 and 2x G 1/4 (BSPP) 	<p>EF 30(41)</p> 	<p>EF 42</p> 
<p>EF 31 EF 31 D</p>	<p>Special end plate for valve section with integrated load-holding valves. Additionally with integrated 3/2-way directional valve for differential circuit (regeneration function).</p> <ul style="list-style-type: none"> ▪ EF 31 D: electro-hydraulic actuation of regeneration function by means of a 2/2 directional seated valve (type EM 21 D as per D 7490/1) 	<p>EF 31</p> 	<p>EF 31 D</p> 

2.6 End plate

End plates are the final element in a manifold and close off the valve bank.

Depending on the version, they feature ports themselves (e.g. P, R or LS port) or additional valves (e.g. flow control valve or pressure reducing valves) for supplying downstream valves.

Ports as per ISO 228-1 (BSPP) or SAE J 514:

- **T, Y:** G 1/4 or SAE-4 (7/16-20 UNF-2B)
- **P, R:** G 3/4 or SAE-10 (7/8-14 UNF-2B)

Table 34 End plates

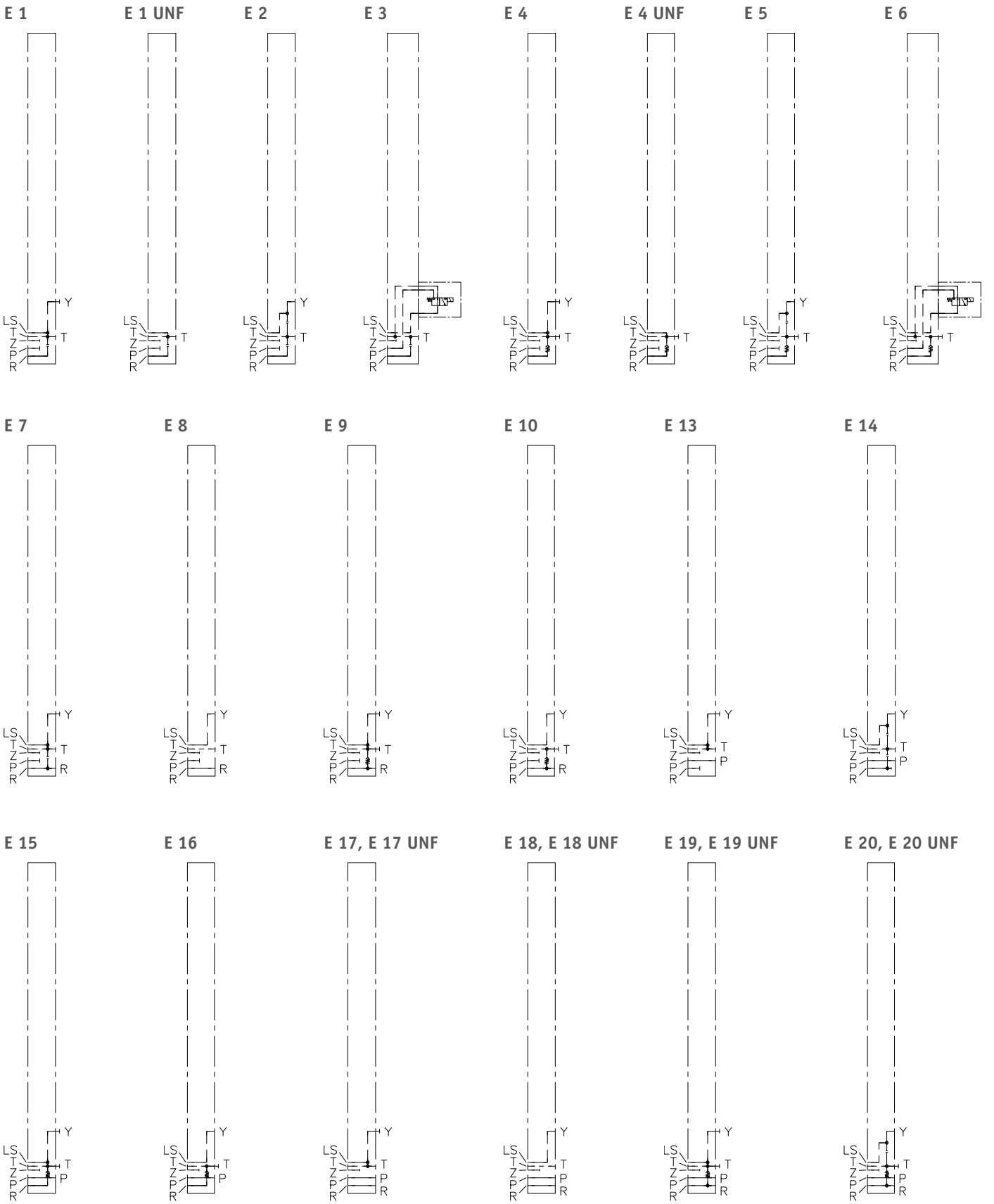
Coding	Description
E 1, E 1 UNF E 7 E 13 E 17, E 17 UNF	T port for external recirculation of control oil to tank. <ul style="list-style-type: none"> ▪ E 7: with additional R port ▪ E 13: with additional P port ▪ E 17: with additional P and R port
E 4, E 4 UNF E 9 E 15 E 19, E 19 UNF	T gallery internally linked with R gallery for internal recirculation of control oil through R line. <ul style="list-style-type: none"> ▪ E 9: with additional R port ▪ E 15: with additional P port ▪ E 19: with additional P and R port
E 2 E 8 E 14 E 18, E 18 UNF	Version with Y port and shuttle valve for connecting a downstream manifold's LS signal. T port for external recirculation of control oil to tank. <ul style="list-style-type: none"> ▪ E 8: with additional R port ▪ E 14: with additional P port ▪ E 18: with additional P and R port
E 5 E 10 E 16 E 20, E 20 UNF	Version with Y port and shuttle valve for connecting a downstream manifold's LS signal. T gallery internally linked with R gallery for internal recirculation of control oil through R line. <ul style="list-style-type: none"> ▪ E 10: with additional R port ▪ E 16: with additional P port ▪ E 20: with additional P and R port
E 3 E 6	With integrated 3/2-way directional valve (WN 1 H as per D 7470 A/1) to switch P to LS when required and shut off the PSL connection block's unpressurised circulation. <ul style="list-style-type: none"> ▪ E 3: T port for external recirculation of control oil to tank ▪ E 6: T gallery internally linked with R gallery for internal recirculation of control oil through R line



NOTE

Internal control oil recirculation through R line is permissible only for return pressures < 10 bar.

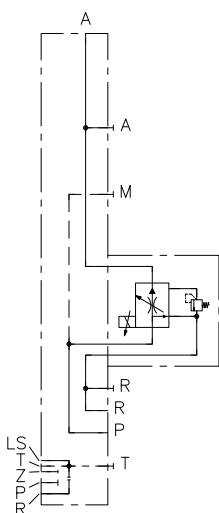
Circuit symbols



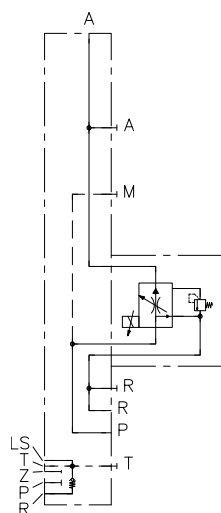
Coding	Description
E 1 SEH. 3-4/...FP... E 4 SEH. 3-4/...FP...	<p>As for E 1 or E 4 but with mounted 3-way flow control valve type SEH. 3-4 as per D 7557/1 for controlling a proportional flow rate to a downstream manifold.</p> <p>Common application is for supplying simple black/white actuation NG 6 manifolds used for additional functions in the vehicle.</p> <p>Example order coding: E4 SEHD 3-4/70 FPS-230</p>
E 28-ADM 22 .-.... E 28-PDM 22 .-....	<p>As E 4 but with mounted pressure reducing valve for controlling pressure to port Z 3 for attaching a 4/2-way directional valve type SWS 2 as per D 7951</p> <ul style="list-style-type: none"> ▪ E 28-ADM 22 .-....: With mechanically adjustable pressure reducing valve type ADM 22 as per D 7120 ▪ E 28-PDM 22 .-....: With electro-proportionally adjustable pressure reducing valve type PDM 22 as per D 7584/1 <p>Example order coding: E 28-ADM 22 D-50-SWS 2</p>

Circuit symbols

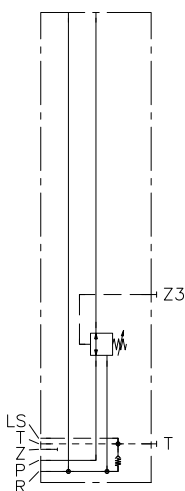
E 1 SEH. 3-4/...FP...



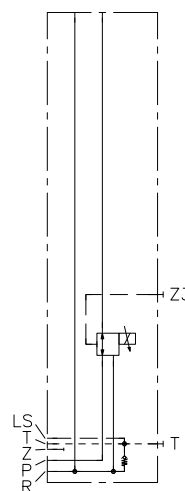
E 4 SEH. 3-4/...FP...



E 28-ADM 22 .-....



E 28-PDM 22 .-....



2.7 Solenoid voltage and solenoid version

Table 35 Standard solenoid versions

Coding	Electrical connection	Rated voltage	Protection class (IEC 60529)	Valve section with electro-hydraulic actuation (EI, EA, EH, EHA etc.)	Can be combined with certain additional valves				
					WN	BVE	EM, EMP	F, FH	FP, FPH
AMP 12 K 4 AMP 24 K 4	AMP Junior Timer	12 V DC 24 V DC	IP 67	4-pin, connector position front		●	●		●
AMP 12 H 4 AMP 24 H 4		12 V DC 24 V DC		4-pin, connector position side (bottom)		●	●		●
AMP 12 H 4 T AMP 24 H 4 T		12 V DC 24 V DC		4-pin, connector position side (bottom), with override		●	●		●
AMP 12 K AMP 24 K		12 V DC 24 V DC		3-pin, connector position front		●	●		●
DT 12 DT 24	Deutsch (DT 04-4P)	12 V DC 24 V DC	IP 69k	4-pin, connector position side (bottom)		●	●		●
DT 12 T DT 24 T		12 V DC 24 V DC		4-pin, connector position side (bottom), with override		●	●		●
DT 12 TH DT 24 TH		12 V DC 24 V DC		4-pin, connector position side (bottom), with override button		●	●		●
DT 12 K DT 24 K		12 V DC 24 V DC		4-pin, connector position front		●	●		●
S 12 S 24	Bayonet coupling PA6 Schlemmer	12 V DC 24 V DC	IP 67	3-pin, connector position front	●	●	●		●
S 12 T S 24 T		12 V DC 24 V DC		3-pin, connector position front, with override	●	●	●		●
G 12 G 24	DIN EN 175 301-803 A <ul style="list-style-type: none"> ▪ G: with male connector (MSD 3-309 as per D 7163) ▪ X: without male connector ▪ L: with male connector with LED (SVS 296365 as per D 7163) ▪ L5K: with male connector with LED and 5 m cable (L5K-VZP as per D 7163 Erg. 78/1) ▪ L10K: with male connector with LED and 10 m cable (L10K-VZP as per D 7163 Erg. 78/1) 	12 V DC 24 V DC	IP 65	3-pin, connector position side (bottom)	●	●	●	●	●
X 12 X 24		12 V DC 24 V DC		●	●	●	●	●	
L 12 L 24		12 V DC 24 V DC		●	●	●	●	●	
L5K 12 L5K 24		12 V DC 24 V DC		●	●	●	●	●	
L10K 12 L10K 24		12 V DC 24 V DC		●	●	●	●	●	
G 12 T G 24 T		12 V DC 24 V DC		3-pin, connector position side (bottom), with override	●	●	●	●	●
X 12 T X 24 T		12 V DC 24 V DC		●	●	●	●	●	
L 12 T L 24 T		12 V DC 24 V DC		●	●	●	●	●	
L5K 12 T L5K 24 T		12 V DC 24 V DC		●	●	●	●	●	
L10K 12 T L10K 24 T		12 V DC 24 V DC		●	●	●	●	●	

Coding	Electrical connection	Rated voltage	Protection class (IEC 60529)	Valve section with electro-hydraulic actuation (EI, EA, EH, EHA etc.)	Can be combined with certain additional valves							
					WN	BVE	EM, EMP	F, FH	FP, FPH			
G 12 TH G 24 TH	DIN EN 175 301-803 A <ul style="list-style-type: none"> ▪ G: with male connector (MSD 3-309 as per D 7163) ▪ X: without male connector ▪ L: with male connector with LED (SVS 296365 as per D 7163) ▪ L5K: with male connector with LED and 5 m cable (L5K-VZP as per D 7163 Erg. 78/1) ▪ L10K: with male connector with LED and 10 m cable (L10K-VZP as per D 7163 Erg. 78/1) 	12 V DC 24 V DC	IP 65	3-pin, connector position side (bottom), with override button	●	●	●	●	●			
X 12 TH X 24 TH		12 V DC 24 V DC			●	●	●	●	●			
L 12 TH L 24 TH		12 V DC 24 V DC			●	●	●	●	●			
L5K 12 TH L5K 24 TH		12 V DC 24 V DC			●	●	●	●	●			
L10K 12 TH L10K 24 TH		12 V DC 24 V DC			●	●	●	●	●			
G 12 DS * G 24 DS *		12 V DC 24 V DC			3-pin, connector position side (bottom), deep-sea version (coil and connector socket not potted)							
X 12 DS * X 24 DS *		12 V DC 24 V DC										
G 12 H 4 G 24 H 4		12 V DC 24 V DC				4-pin, connector position side (bottom)	●	●	●	●		
X 12 H 4 X 24 H 4		12 V DC 24 V DC			●		●	●	●			
L 12 H 4 L 24 H 4		12 V DC 24 V DC			●		●	●	●			
X 12 C X 24 C		DIN EN 175 301-803 C			12 V DC 24 V DC	IP 65	3-pin, connector position front					
X 12 C 4 X 24 C 4					12 V DC 24 V DC			4-pin, connector position front				
DTL 12 DTL 24	MIL-DTL-38999 series III	12 V DC 24 V DC	IP 67	4-pin, connector position side (bottom)			●					
ITT 12 ITT 24	VG 95234 MIL	12 V DC 24 V DC					●					

* (available upon request only)

Electrical connection for additional valves:

- **WN:** see [D 7470 A/1](#)
- **BVE:** see [D 7921](#)
- **EM 21:** see [D 7490/1 E](#)
- **EM 3, EMP 4:** see [D 7490/1](#)
- **SEH:** see [D 7557/1](#)
- **PDM:** see [D 7584/1](#)
- **SWS:** see [D 7951](#)
- **PMVP:** see [D 7485/1](#)

Different connector designs (e.g. EA actuation with AMP 24 K 4 and WN valve with G 24) are available upon request.

Electrical connection for LS relief coding F 1, F 2, F3, FH 1, FH 2, FH 3:

The LS relief's black/white twin solenoids are only available with DIN connectors and manual override (coding -G...T(H), -X...T(H) or -L...T(H)). Should you require another connector variant, the electro-proportional LS pressure limitation coding FP., FPH.. can be used instead.

Electrical connection for electro-proportional LS pressure limitation coding FP., FPH..:

Only twin solenoids with manual override (coding -...T or -...TH) are possible.

If a twin solenoid without manual override was chosen for the valve section's electro-hydraulic actuation, the same twin solenoid is automatically used for the LS pressure limitation's electro-proportional actuation, but with additional manual override.

If the twin solenoid is not possible with manual override, coding -G...T is used by default.

Table 36 Solenoid versions for potentially explosive atmospheres

Coding	Description
X 24 TEX 4 70 FM	Explosion-proof solenoid in terminal box For additional details, see operating and maintenance manual B ATEX
G 24 EX G 24 EX-10 m G 24 EX-20 m	Explosion-proof solenoid with cable <ul style="list-style-type: none"> ▪ No additional specification: with 3 m cable
G 24 TEX G 24 TEX-10 m G 24 TEX-20 m	<ul style="list-style-type: none"> ▪ 10 m: with 10 m cable ▪ 20 m: with 20 m cable
G 24 EX 4 G 24 EX 4-10 m	For additional details, see operating and maintenance manual B ATEX
G 24 TEX 4 G 24 TEX 4-10 m	
G 24 TEX 4 55 G 24 TEX 4 55-10 m	
G 24 TEX 4 55 FM G 24 TEX 4 55 FM-10 m	
G 24 TEX 70 G 24 TEX 70-10 m G 24 TEX 70-20 m	
G 24 TEX 70 FM-10 m	
G 24 TEX 70 FM2-10 m	
G 24 TEX 70 FM4-10 m	
G 12 IS G 12 IS-10 m	Explosion-proof solenoid with cable. <ul style="list-style-type: none"> ▪ No additional specification: with 3 m cable
G 24 M2FP G 24 M2FP-10 m	<ul style="list-style-type: none"> ▪ 10 m: with 10 m cable
G 24 MSHA G 24 MSHA-10 m G 24 MSHA-20 m	<ul style="list-style-type: none"> ▪ 20 m: with 20 m cable <p>An additional 5-mm spacer plate is required between the separate valve sections (SL 3-ZPL 33/5).</p> <p>For additional details, see operating and maintenance manual B ATEX</p>

3 Parameters

3.1 General and hydraulic

General information

Designation	Proportional directional spool valve PSL/PSV/PSM	
Design	Manifold with up to 12 valve sections	
Material	Steel, nitrided surfaces, internal function parts tempered and polished, solenoids' surfaces galvanised	
Attachment	Metric attachment thread M8, see Chapter 4, "Dimensions"	
Installation position	As desired	
Connections	P	Pump
	R	Reflux
	A, B	Consumer
	LS, DW, U, W, X, XH, Y	Load pressure signal
	M	Pressure gauge connection for pump pressure
	a, b	Pressure gauge connection for consumer pressure
	Z	Pilot pressure
	T	Tank line for control oil
	Connecting thread:	
	<ul style="list-style-type: none"> ▪ P, R, A, B: as per type designation ▪ M, LS, DW, Y, Z, T: G 1/4 (ISO 228-1) (BSPP) or SAE-4, or 7/16-20 UNF-2B (SAE J 514) ▪ U, W, X, XH: G 1/8 (ISO 228-1) (BSPP) ▪ a, b: G 1/4 or G 1/8 (ISO 228-1) (BSPP) 	
Hydraulic fluid	Hydraulic oil: according to part 1 to 3; ISO VG 10 to 68 according to DIN ISO 3448 Viscosity limits: min. approx. 4, max. approx. 1500 mm ² /s opt. operation approx. 10... 500 mm ² /s. Also suitable for biologically degradable hydraulic fluids type HEPG (polyalkylene glycol) and HEES (synthetic ester) at operating temperatures up to approx. +70°C. Not suitable for HETG such as rapeseed oil and water-glycol solutions such as HFA or HFC.	
Cleanliness level	ISO 4406 <hr style="width: 50%; margin-left: 0;"/> 20/17/14	

Temperatures

Environment: approx. -40 to +80°C, oil: -25 ... +80°C, pay attention to the viscosity range. Start temperature: down to -40°C is permissible (observe start viscosities!), as long as the steady-state temperature is at least 20K higher during subsequent operation. Biologically degradable hydraulic fluids: note manufacturer specifications. With consideration for the seal compatibility, not above +70°C.

i NOTE

Note restrictions on explosion-proof solenoid.

Pressure and flow rate

Operating pressure

- $p_{max} = 420$ bar (ports P, P1, P2, A, B, LS, M, Y)
- Pilot pressure ≤ 40 bar (port Z)
- Return pressure ≤ 50 bar (ports R, R1, T) for high return pressures, T port should be routed to the tank separately (see also end plate E 1, E 2, E 3 etc. as per "Table 34")

Flow rate

- Q_{max} connection block: see [Chapter 3.2, "Characteristics"](#)
- Q_{max} consumer: see ["Table 15 Flow rate"](#)

Weight

Connection block

Type

PSL 3, 4	= 3.8 kg
PSL 5	= 4.3 kg
PSV 3, 4, 5	= 3.6 kg
PSV 45, PSV 55	= 4.3 kg
PSV 6	= 3.3 kg
PSM 5	= 4.3 kg

Supplement

F, D, PA, PB, PC, PD	= 0.6 kg
----------------------	----------

Directional valve section

Valve section with actuation

Coding

A, H, F, P, E0A	= 3.3 kg
HA, FA	= 3.6 kg
EA, PA, K	= 3.7 kg
HEA, FEA, KE	= 4.0 kg

Ancillary block	<p>Coding</p> <p>/3, /UNF 3 = 0.6 kg</p> <p>/3 AS... BS..., /31 AS... BS..., /UNF 3 AS... BS... = 0.8 kg</p> <p>/3 DW., /4 DW., /UNF 4 DW. = 0.8 kg</p> <p>/4, /4 AN BN, /UNF 3 AN BN. = 0.9 kg</p> <p>/3 DRH, /UNF 3 DRH, /43 DFA, /43 DFB = 1.1 kg</p> <p>/3 VX, /3 XV, /3 SX, /3 XS, /UNF 3 VX, /UNF 3 XV, /UNF 3 SX, /UNF 3 XS = 1.5 kg</p> <p>/4 AN..., /4 BN... = 1.7 kg</p> <p>/4 AS... BS..., /3 AN... BN..., /31 AN... BN..., /UNF 3 AN... BN..., /4 AN... BN... = 1.8 kg</p> <p>/3 VV, /UNF 3 VV = 1.9 kg</p> <p>/3 AL... BL..., /3 AL..., /3 BL..., /3 AC... BC..., /3 ACX... BCX..., /UNF 3 AL... BL..., /UNF 3 AL..., /UNF 3 BL..., /UNF 3 AC... BC..., /UNF 3 ACX... BCX... = 2.0 kg</p>
Intermediate plate	<p>Coding</p> <p>ZDR, ZDS = 1.0 kg</p> <p>ZAL... BL... = 2.0 kg</p>
Series intermediate plate	<p>Coding</p> <p>ZPL 33/5 = 0.3 kg</p> <p>ZPL 33/15 = 0.8 kg</p> <p>ZPL 32 = 1.2 kg</p> <p>ZPL 33, ZPL 3-Z 3 = 1.9 kg</p> <p>ZPL 3 P/... = 2.5 kg</p> <p>ZPL 3 S(V)/H = 2.7 kg</p> <p>ZPL 3 S(V)/E = 3.3 kg</p> <p>ZPL 3 DS/... = 3.6 kg</p> <p>ZPL 3 D/.. = 3.6 kg</p>
End plates	<p>Coding</p> <p>E 1, E 2, E 4, E 5, E 1 UNF, E 4 UNF = 1.0 kg</p> <p>E 3, E 6 = 1.6 kg</p> <p>E 17, E 18, E 19, E 20, E 17 UNF, E 20 UNF = 2.1 kg</p>

3.2 Characteristics

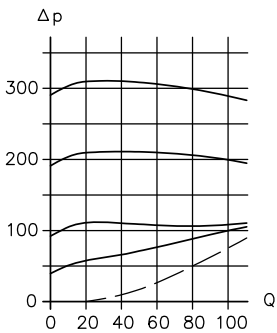
Oil viscosity approx. 60 mm²/s

Connection block

Pressure-limiting valve (P → R)

PSL 3(4).../...-3, PSL 4 Y(Z, K).../...-3, PSL JIS 4.../...-3
PSV 3(4, 5).../...-3, PSV 5 N...-3, PSV UNF 5 N...-3

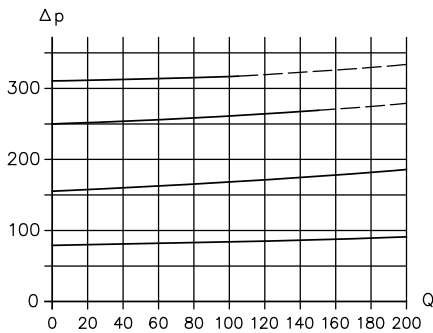
PSL 3(4).../...-3



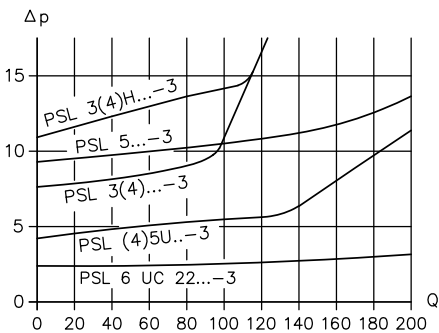
Q flow rate (lpm); Δp pressure difference (bar)

PSL 45(5, UNF 4).../...-3, PSL 6...UC 22 2/...-3
PSV 45(55, UNF 44).../...-3
PSM 5.../...-3, PSM 5 L.../...-3, PSM UNF 4.../...-3

PSL 5.../...-3



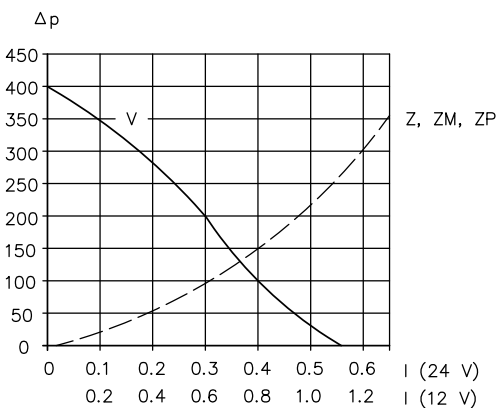
Circulation pressure (P → R) in PSL connection blocks



Q flow rate (lpm); Δp pressure difference (bar)

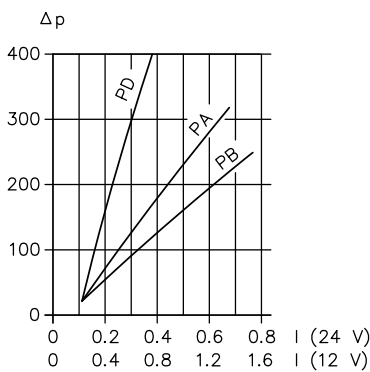
Electro-proportional LS pressure limitation as per "Table 7"

Coding **V, Z, ZM, ZP**



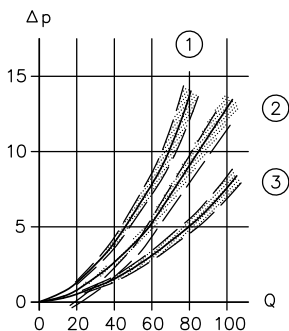
I control current (A) at 24 V DC or 12 V DC; Δp pressure difference LS - R (bar)

Coding **PA, PB, PD**



Directional valve section

Pressure difference $P \rightarrow A/B$ and $A/B \rightarrow R$

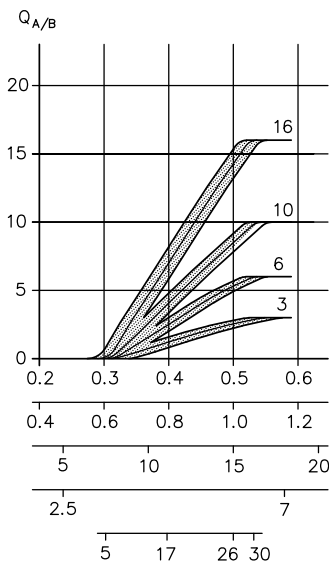


Q flow rate (lpm); Δp pressure difference (bar)

- 1 $P \rightarrow A/B$ in valve section with 2-way controller (see also ["Table 11: Valve section, 2-way controller"](#))
- 2 $P \rightarrow A/B$ in valve section without 2-way controller (see also ["Table 11: Valve section, 2-way controller"](#))
- 3 $A/B \rightarrow R$ in spool valve coding L, M, F, H (see also ["Table 14: Circuit symbol"](#))

Control characteristic curve consumer/flow rate as per ["Table 15"](#)

(reference values measured with 2-way controller and standard 2-way controller spring)



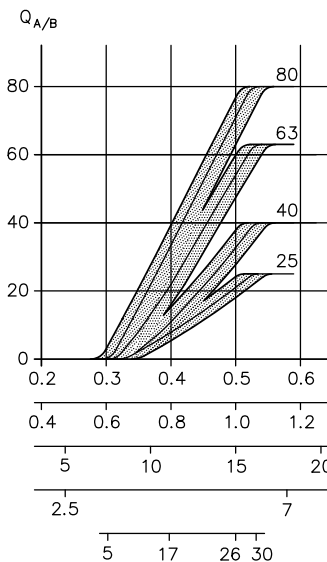
I (24 V)

I (12 V)

$p_{hydr.}$

$p_{pneum.}$

Switching angle



I (24 V)

I (12 V)

$p_{hydr.}$

$p_{pneum.}$

Switching angle

$Q_{A/B}$ flow rate (lpm);

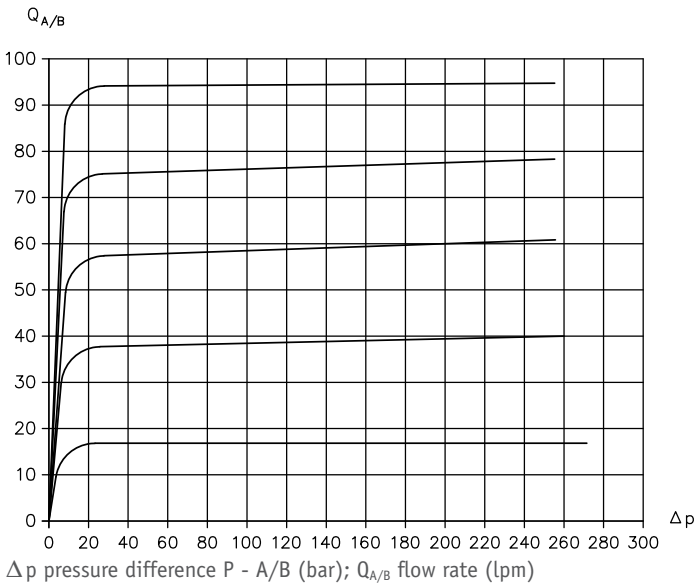
I control current (A) at 24 V DC or 12 V DC for electro-hydraulic actuation

$p_{hydr.}$ pilot pressure (bar) for hydraulic actuation

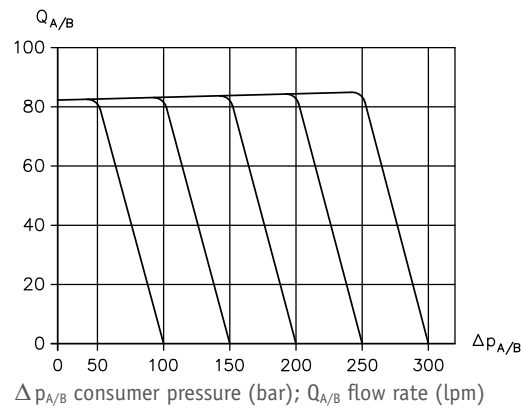
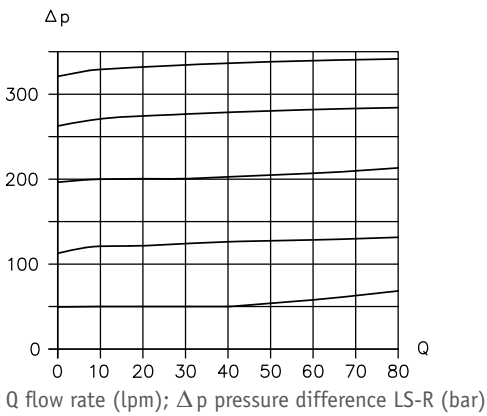
$p_{pneum.}$ Pilot pressure (bar) for pneumatic actuation

Switching angle ($^\circ$) for manual actuation with hand lever

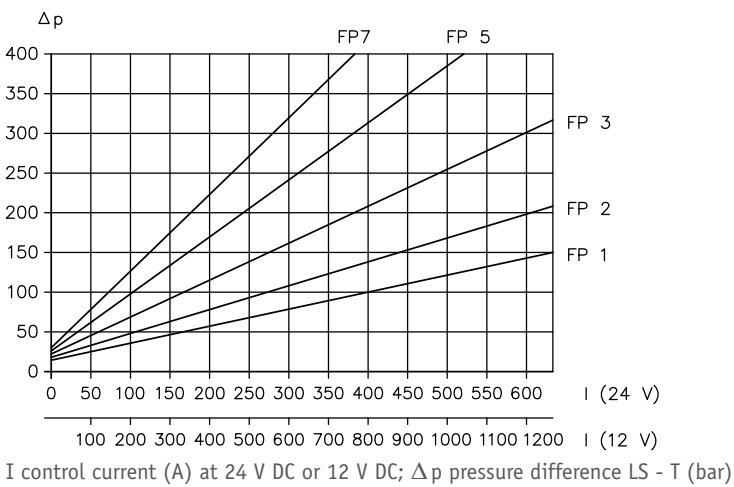
2-way controller as per ["Table 11"](#)



LS pressure-limiting valves as per ["Table 16"](#)

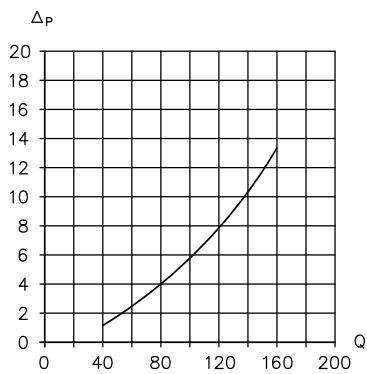


Electro-proportional LS pressure limitation as per ["Table 17"](#)



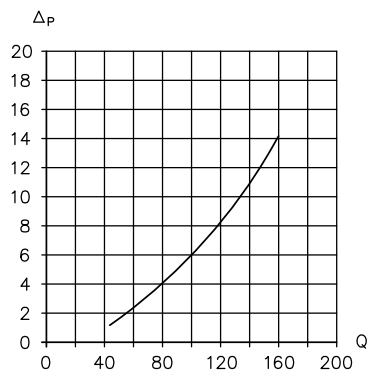
Series intermediate plate A1 RR PVPV/5

Pressure difference P → H (extend)



Q flow rate (lpm); Δp pressure difference P - H (bar)

Pressure difference H → R (retract)



Q flow rate (lpm); Δp pressure difference H - R (bar)

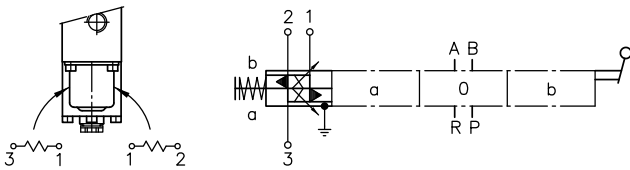
3.3 Electrical parameters

3.3.1 Electro-hydraulic actuation EI, EA, EH, EF etc. with standard solenoid

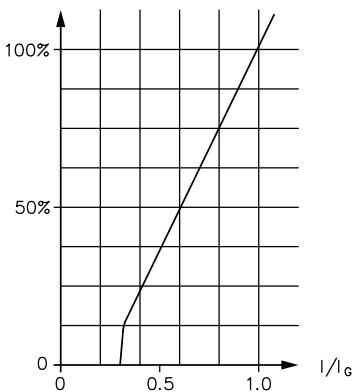
Proportional solenoid, produced and tested in accordance with DIN VDE 0580

Twin solenoid with anchor chambers sealed on the outside and connected to the return duct. The anchors in the anchor chambers are thereby lubricated by the hydraulic oil and protected against corrosion without the need for maintenance.

Nominal voltage	12 V DC	24 V DC
Resistance R_{20}	6.3 Ω	27.0 Ω
Current, cold I_{20}	1.9 A	0.9 A
Limit current I_G	1.26 A	0.63 A
Limit power P_G	15.1 W	15.1 W
Actuated time	S1 (100 %)	
Dither frequency	40 to 70 Hz (recommended value: 55 Hz)	
Dither amplitude $A_D(\%) = \frac{I_{Spitze-Spitze}}{I_G} \cdot 100$	$20\% \leq A_D \leq 50\%$	



I stroke characteristic curve

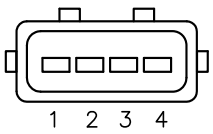
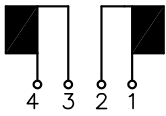


I , I_G control current (A); spool stroke (%)

Electrical connection

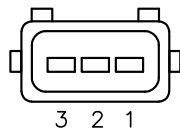
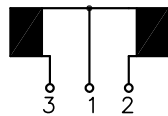
Coding
**AMP 12(24) K4, AMP 12(24) H4,
AMP 12(24) H4T**

AMP Junior Timer
4-pin
IP 67 (IEC 60529)



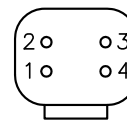
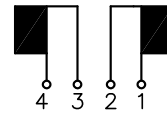
Coding
AMP 12(24) K

AMP Junior Timer
3-pin
IP 67 (IEC 60529)



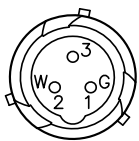
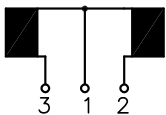
Coding
**DT 12(24), DT 12(24) T,
DT 12(24) K**

Deutsch (DT 04-4P)
4-pin
IP 69k (IEC 60529)



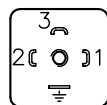
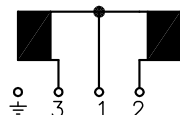
Coding
S 12(24), S 12(24) T

Bayonet coupling PA6 Schlemmer
3-pin
IP 67 (IEC 60529)



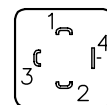
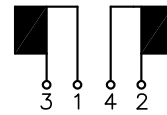
Coding
**G 12(24), X 12(24), L 12(24),
G 12(24) T, X 12(24) T, L 12(24) T,
G 12(24) TH, X 12(24) TH, L 12(24) TH,
G 12(24) DS, X 12(24) DS**

DIN EN 175 301-803 A
3-pin
IP 65 (IEC 60529)



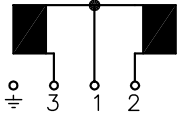
Coding
**G 12(24) H4, X 12(24) H4,
L 12(24) H4**

DIN EN 175 301-803 A
4-pin
IP 65 (IEC 60529)



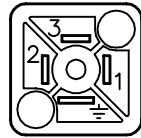
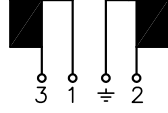
Coding
X 12(24) C

DIN EN 175 301-803 C
3-pin
IP 65 (IEC 60529)



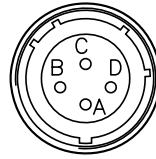
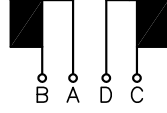
Coding
X 12(24) C4

DIN EN 175 301-803 C
4-pin
IP 65 (IEC 60529)



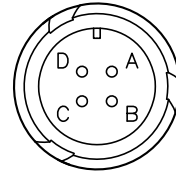
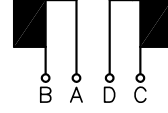
Coding
DTL 12(24)

MIL-DTL-38999 Series III
4-pin
IP 67 (IEC 60529)



Coding
ITT 12(24)

VG 95234 MIL
4-pin
IP 67 (IEC 60529)



3.3.2 Electro-hydraulic actuation EI, EA, EH, EF etc. with solenoid for potentially explosive atmospheres

i NOTE

When using solenoids for potentially explosive atmospheres, always observe the operating and maintenance manual [B ATEX](#) and the separate operating and maintenance manual for the respective solenoid.

Refer to the applicable operating and maintenance manual for operating thresholds, classifications, electrical parameters and electrical connections.

Coding	Operating and maintenance manual with declaration of conformity
X 24 TEX 4 70 FM	<ul style="list-style-type: none"> ▪ B ATEX ▪ B 41/2017 (EX23)
G 24 EX G 24 EX-10 m G 24 EX-20 m	<ul style="list-style-type: none"> ▪ B ATEX ▪ B 01/2002 (EX01)
G 24 TEX G 24 TEX-10 m G 24 TEX-20 m	
G 24 EX 4 G 24 EX 4-10 m	
G 24 TEX 4 G 24 TEX 4-10 m	
G 24 TEX 4 55 G 24 TEX 4 55-10 m	<ul style="list-style-type: none"> ▪ B ATEX ▪ B 19/2011 (EX08)
G 24 TEX 4 55 FM G 24 TEX 4 55 FM-10 m	<ul style="list-style-type: none"> ▪ B ATEX ▪ B 22/2011 (EX11)
G 24 TEX 70 G 24 TEX 70-10 m G 24 TEX 70-20 m	<ul style="list-style-type: none"> ▪ B ATEX ▪ B 09/2006 (EX06)
G 24 TEX 70 FM-10 m	<ul style="list-style-type: none"> ▪ B ATEX
G 24 TEX 70 FM2-10 m	<ul style="list-style-type: none"> ▪ B 21/2011 (EX12)
G 24 TEX 70 FM4-10 m	
G 12 IS G 12 IS-10 m	<ul style="list-style-type: none"> ▪ B ATEX ▪ B 17/2011 (EX05)
G 24 M2FP G 24 M2FP-10 m	<ul style="list-style-type: none"> ▪ B ATEX ▪ B 04/2005 (EX05)
G 24 MSHA G 24 MSHA-10 m G 24 MSHA-20 m	

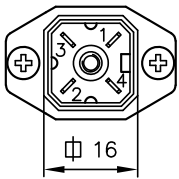
3.3.3 Switching position monitoring, displacement transducer

Coding V, VA, VB, VC

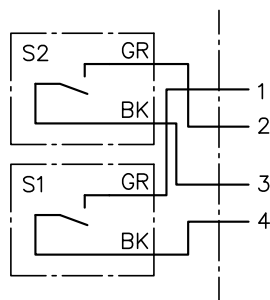
Cable	Cable: <ul style="list-style-type: none"> ▪ 3 x 0.5 mm² wire with PVC insulation; 50 cm long ▪ Black: Input ▪ Blue: NO contact ▪ Green: N/C contact
Resistance load up to 30 V DC	5 A
Inductive load	3 A
Protection class	IP 67 (IEC 60529)

Coding VCHO, VCHC

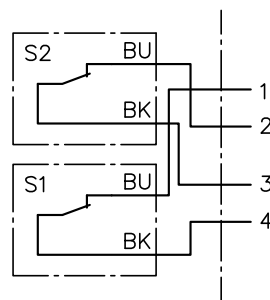
Connector	G 4 W 1 F® Hirschmann
Resistance load up to 30 V DC	5 A
Inductive load	3 A
Protection class	IP 65 (IEC 60529)
Labelling	<ul style="list-style-type: none"> ▪ VCHO: NO ▪ VCHC: NC



VCHO



VCHC



Contact switch S2 = towards A
Contact switch S1 = towards B

Coding N

Model	IFFM 08P/3701/02L® BAUMER Electric GmbH 8x8x40 mm with LED display N/C contact, positive-switching and flush
Power cable	∅ 3 mm, 3-core PVC, 2 m long
Operating voltage	10 to 30 V DC
Current consumption without load	up to 10 mA
Max. load current	200 mA
Operating temperature	-25 to 80°C
Protection class	IP 67 (IEC 60529)

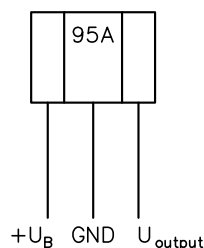
Coding WA

Coding	Electrical connection	Protection class (IEC 60529)
WA	DIN EN 175 301-803 A	IP 65
WA-S	Bayonet coupling PA6 Schlemmer	IP 67
WA-AMP	AMP Junior Timer	IP 67
WA-DT	Deutsch (DT 04-4P)	IP 69k
WA-C	DIN EN 175 301-803 C	IP 65

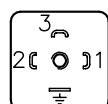
Pin assignment:

1 = U_{output}
 2 = $+U_B$ (5 to 10 V)
 3 = GND
 Earth = not assigned

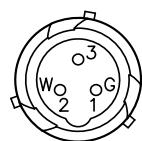
Sensor assignment:



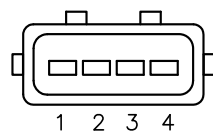
WA



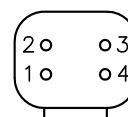
WA-S



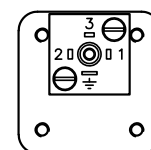
WA-AMP

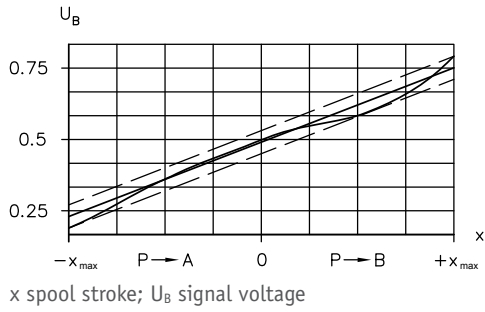


WA-DT



WA-C





U_B = supply voltage
 $U_{B \max} = 76\%$
 $U_{B \min} = 24\%$
 Accuracy $\pm 9\%$ (of U_B)

Use stabilised, smoothed DC voltage only.

NOTE
 The displacement transducer will be destroyed by strong magnetic fields.

Coding U

Protection class IP 65 (IEC 60529)

Pin assignment

Pin	Signal	Description
1	OUTA	PNP positive-switching
2	OUTB	PNP positive-switching
3	+ U_B	10 ... 32 V DC
⊕	GND	0 V DC

Open-Collector:
 $I_{\max} = 10 \text{ mA}$
 Short-circuit-proof

Status table

No.	Spool valve action	Signal outputs PNP transistor with open collector:	
		OUTA	OUTB
1	Neutral position in centre	ON	ON
2	P → B	OFF	ON
3	P → A	ON	OFF

U



3.3.4 Switching position monitoring, displacement transducer for potentially explosive atmospheres

i NOTE

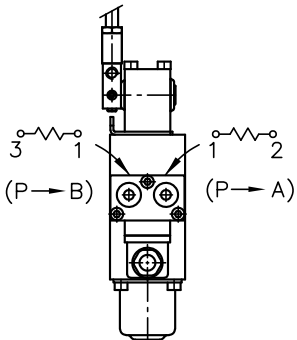
When using displacement transducers for potentially explosive atmospheres, always observe the operating and maintenance manual [B ATEX](#) and the separate operating and maintenance manual for the respective displacement transducer. Refer to the applicable operating and maintenance manual for operating thresholds, classifications, electrical parameters and electrical connections.

Coding	Operating and maintenance manual with declaration of conformity
WA-EX	<ul style="list-style-type: none"> ▪ B ATEX ▪ B 10/2008 (EX09)
WA-M2FP	<ul style="list-style-type: none"> ▪ B ATEX ▪ B 10/2008 (EX09)
WA-IS	<ul style="list-style-type: none"> ▪ B ATEX ▪ B 31/2013 (EX16)

3.3.5 Electric LS relief or LS pressure limitation

Electric LS relief coding F 1, F 2, F3, FH 1, FH 2, FH 3

Nominal voltage	12 V DC	24 V DC
Resistance R_{20}	8.7 Ω	34.8 Ω
Current, cold I_{20}	1.38 A	0.69 A
Limit current I_G	0.97 A	0.48 A
Limit power P_G	11.6 W	11.6 W
Actuated time	S1 (100 %)	



i NOTE
Actuated time applies separately for a single twin solenoid coil. If both coils are powered simultaneously, only half that time is permitted actuated time.

i NOTE
The LS relief's black/white twin solenoids are only available with DIN connectors and manual override (coding -G...T(H), -X...T(H) or -L...T(H)).

Electrical connection

Coding

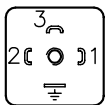
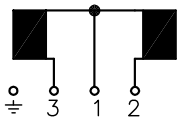
G 12(24) T, X 12(24) T, L 12(24) T

G 12(24) TH, X 12(24) TH, L 12(24) TH

DIN EN 175 301-803 A

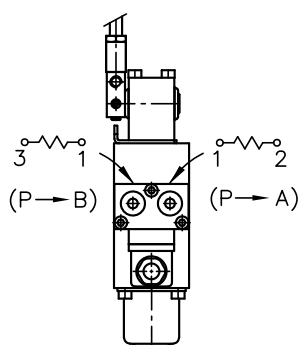
3-pin

IP 65 (IEC 60529)



Electro-proportional LS pressure limitation coding FP., FPH..

Nominal voltage	12 V DC	24 V DC
Resistance R_{20}	6.3 Ω	27.0 Ω
Current, cold I_{20}	1.9 A	0.9 A
Limit current I_G	1.26 A	0.63 A
Limit power P_G	15.1 W	15.1 W
Actuated time	S1 (100 %)	
Dither frequency	40 to 70 Hz (recommended value: 55 Hz)	
Dither amplitude $A_D(\%) = \frac{I_{Spitze-Spitze}}{I_G} \cdot 100$	$20\% \leq A_D \leq 50\%$	



i NOTE

Actuated time applies separately for a single twin solenoid coil. If both coils are powered simultaneously, only half that time is permitted actuated time.

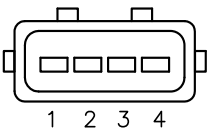
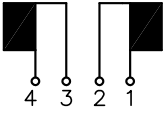
i NOTE

- Only twin solenoids with manual override (coding -...T or -...TH) are possible.
- If a twin solenoid without manual override was chosen for the valve section's electro-hydraulic actuation, the same twin solenoid is automatically used for the LS pressure limitation's electro-proportional actuation, but with additional manual override.
- If the twin solenoid is not possible with manual override, coding -G...T is used by default.

Electrical connection

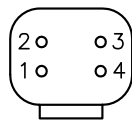
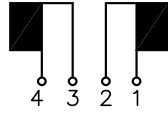
Coding
AMP 12(24) H 4 T

AMP Junior Timer
4-pin
IP 67 (IEC 60529)



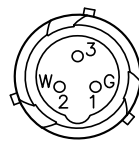
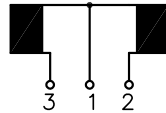
Coding
**DT 12(24) T,
DT 12(24) TH**

Deutsch (DT 04-4P)
4-pin
IP 69k (IEC 60529)



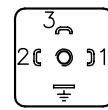
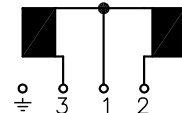
Coding
S 12(24) T

Bayonet coupling PA6
Schlemmer
IP 67 (IEC 60529)



Coding
**G 12(24) T, X 12(24) T,
L 12(24) T, G 12(24) TH,
X 12(24) TH, L 12(24) TH**

DIN EN 175 301-803 A
3-pin
IP 65 (IEC 60529)



3.3.6 Electric LS relief or LS pressure limitation for potentially explosive atmospheres

NOTE

When using solenoids for potentially explosive atmospheres, always observe the operating and maintenance manual [B ATEX](#) and the separate operating and maintenance manual for the respective solenoid.
Refer to the applicable operating and maintenance manual for operating thresholds, classifications, electrical parameters and electrical connections.

Coding	Operating and maintenance manual with declaration of conformity
X 24 TEX 4 70 FM	<ul style="list-style-type: none"> ▪ B ATEX ▪ B 41/2017 (EX23)
G 24 TEX G 24 TEX-10 m G 24 TEX-20 m	<ul style="list-style-type: none"> ▪ B ATEX ▪ B 01/2002 (EX01)
G 24 TEX 4 G 24 TEX 4-10 m	
G 24 TEX 55-10 m G 24 TEX 4 55 G 24 TEX 4 55-10 m	<ul style="list-style-type: none"> ▪ B ATEX ▪ B 19/2011 (EX08)
G 24 TEX 4 55 FM G 24 TEX 4 55 FM-10 m	<ul style="list-style-type: none"> ▪ B ATEX ▪ B 22/2011 (EX11)
G 24 M2FP G 24 M2FP-10 m	<ul style="list-style-type: none"> ▪ B ATEX ▪ B 04/2005 (EX05)
G 24 MSHA G 24 MSHA-10 m G 24 MSHA-20 m	

3.3.7 Additional valves

The available types of plug are detailed in [Chapter 2.7, "Solenoid voltage and solenoid version"](#) . Refer to the respective additional valve's data sheet for electrical parameters.

4 Dimensions

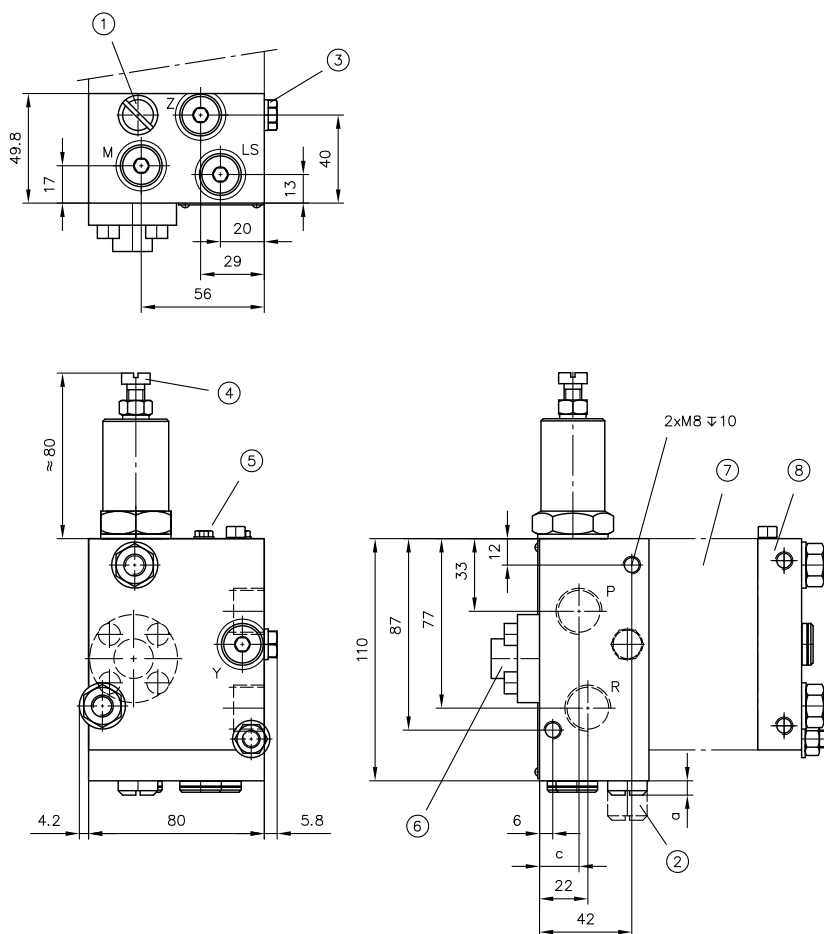
All dimensions in mm, subject to change.

4.1 Connection block

as per ["Table 3: Connection block basic types"](#)

PSL 3.../...-3

PSL 4.../...-3



- 1 Internal control oil supply coding 1 or without designation
- 2 Internal control oil supply coding 2
- 3 LS damping
- 4 Pressure-limiting valve
- 5 Mounting point for additional valve for LS relief or LS pressure limitation
- 6 3-way controller's spring housing
- 7 Valve section
- 8 End plate

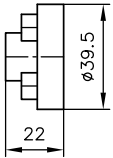
Type	c
PSL 3.../...-3	18
PSL 4.../...-3	21

Coding	a
No designation	6.4
1	6.4
2	18.3

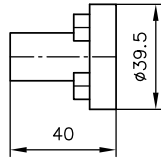
Type	Ports as per ISO 228-1(BSPP)	
	P, R	LS, M, Y, Z
PSL 3.../...-3	G 1/2	G 1/4
PSL 4.../...-3	G 3/4	G 1/4

3-way controller's spring housing

No designation

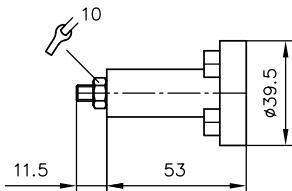


Coding H

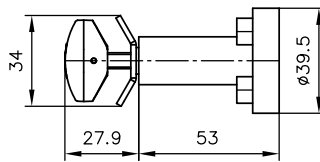


3-way controller's spring housing with locking tapped plug

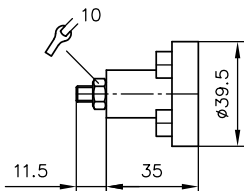
Coding HT



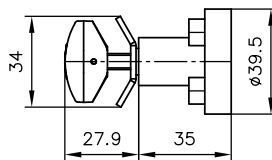
Coding HTR



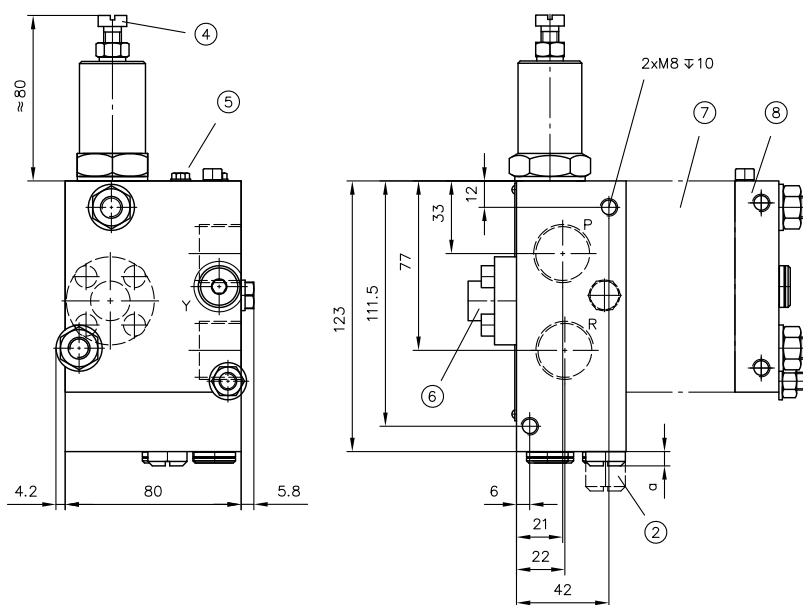
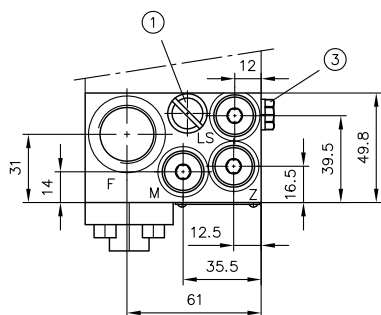
Coding T



Coding TR



PSL 4 Y.../...-3
PSL UNF 4 Y.../...-3

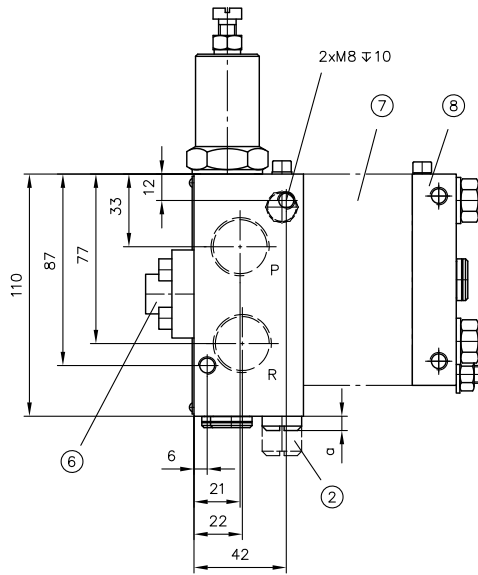
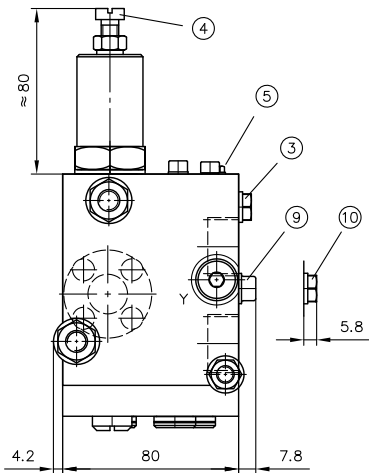
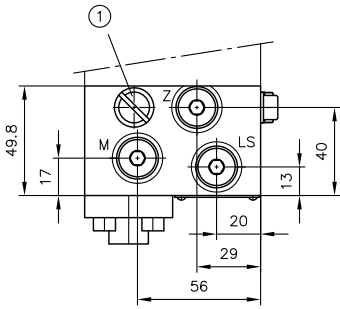


- 1 Internal control oil supply coding 1 or without designation
- 2 Internal control oil supply coding 2
- 3 LS damping
- 4 Pressure-limiting valve
- 5 Mounting point for additional valve for LS relief or LS pressure limitation
- 6 3-way controller's spring housing
- 7 Valve section
- 8 End plate

Coding	a
No designation	6.4
1	6.4
2	18.3

Type	Ports as per ISO 228-1 (BSPP) or SAE J 514	
	F, P, R	LS, M, Y, Z
PSL 4 Y.../...-3	G 3/4	G 1/4
PSL UNF 4 Y.../...-3	SAE-12 (1 1/16-12 UN-2B)	SAE-4 (7/16-20 UNF-2B)

PSL 4 K.../...-3
PSL 4 Z.../...-3

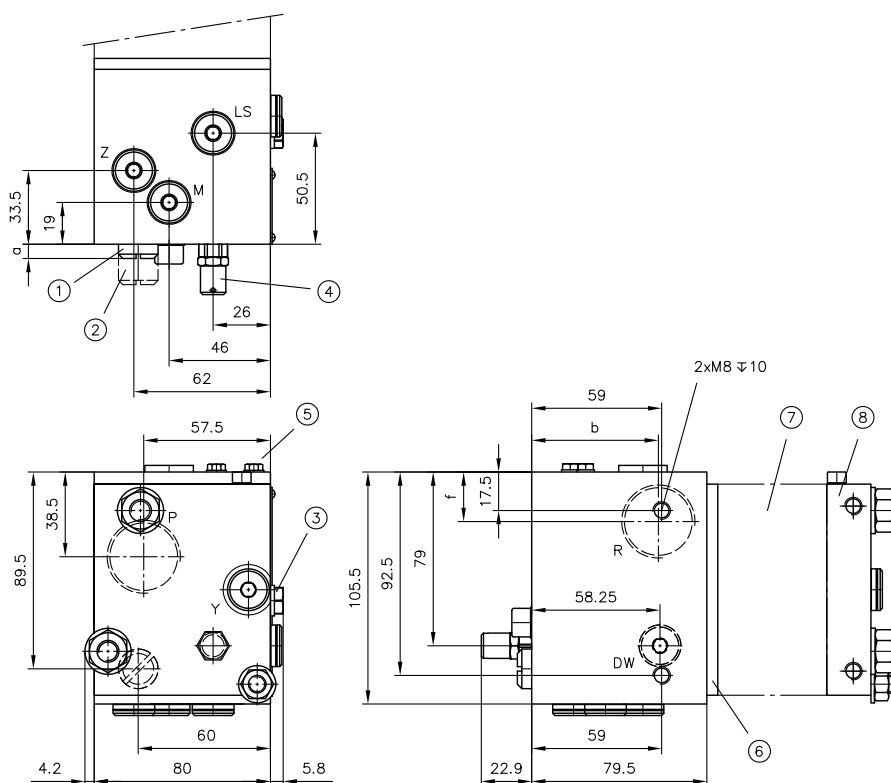


- 1 Internal control oil supply coding 1 or without designation
- 2 Internal control oil supply coding 2
- 3 LS damping
- 4 Pressure-limiting valve
- 5 Mounting point for additional valve for LS relief or LS pressure limitation
- 6 3-way controller's spring housing
- 7 Valve section
- 8 End plate
- 9 PSL 4 K
- 10 PSL 4 Z

Coding	a
No designation	6.4
1	6.4
2	18.3

Type	Ports as per ISO 228-1 (BSPP)	
	P, R	LS, M, Y, Z
PSL 4 K.../...-3	G 1/2	G 1/4
PSL 4 Z.../...-3	G 3/4	G 1/4

PSL 45.../...-3, PSL 5.../...-3, PSL UNF 4.../...-3
 PSV 45.../...-3, PSV 55.../...-3, PSV UNF 44.../...-3



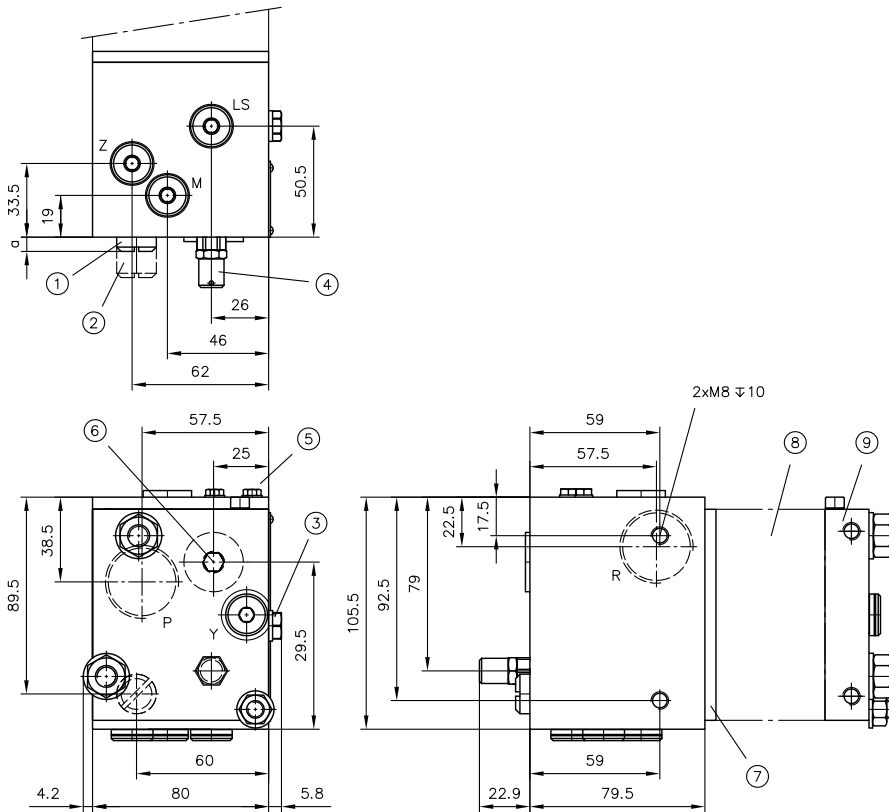
- 1 Internal control oil supply coding 1 or without designation
- 2 Internal control oil supply coding 2
- 3 LS damping
- 4 Pressure-limiting valve
- 5 Mounting point for additional valve for LS relief or LS pressure limitation
- 6 Spacer plate SL 3-ZPL 33/5
- 7 Valve section
- 8 End plate

Type	b	f	Coding	a
PSL 45.../...-3	57.5	22.5	No designation	6.4
PSL 5.../...-3			1	6.4
PSV 45.../...-3			2	18.3
PSV 55.../...-3				
PSL UNF 4.../...-3	53.5	24.5		
PSV UNF 44.../...-3				

Ports as per ISO 228-1 (BSPP) or SAE J 514

	P	R	DW, LS, M, Y, Z
PSL 45.../...-3 PSV 45.../...-3	G 3/4	G 1	G 1/4
PSL 5.../...-3 PSV 55.../...-3	G 1	G 1	G 1/4
PSL UNF 4.../...-3 PSL UNF 44.../...-3	SAE-12 (1 1/16-12 UN-2B)	SAE-12 (1 1/16-12 UN-2B)	SAE-4 (7/16-20 UNF-2B)

PSL 45 U.../...-3
PSL 5 U.../...-3

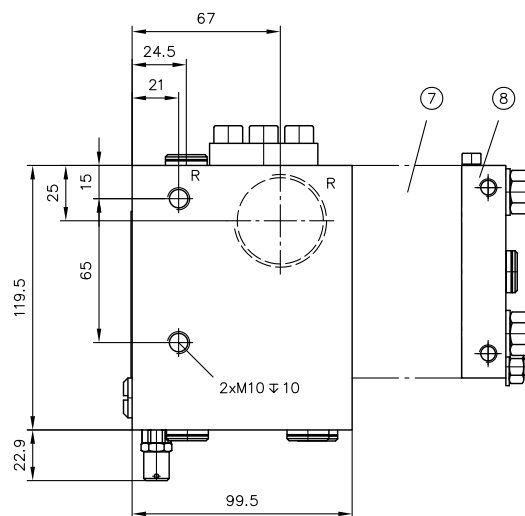
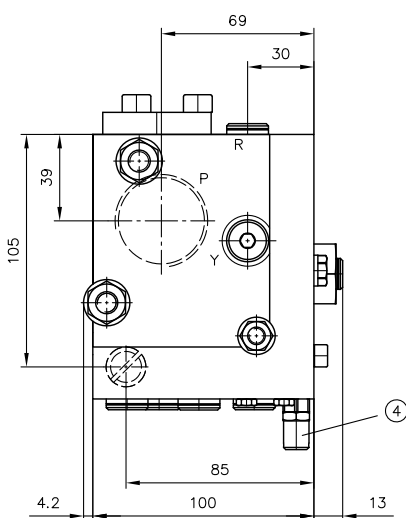
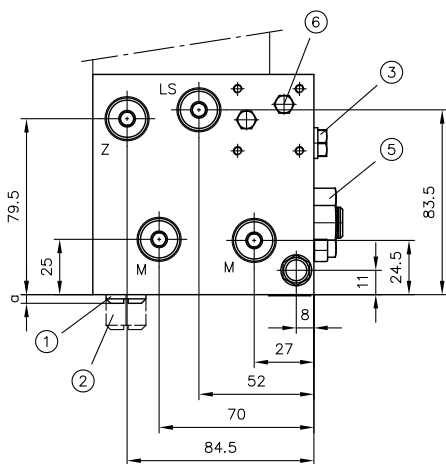


- 1 Internal control oil supply coding 1 or without designation
- 2 Internal control oil supply coding 2
- 3 LS damping
- 4 Pressure-limiting valve
- 5 Mounting point for additional valve for LS relief or LS pressure limitation
- 6 Idle circulation valve
- 7 Spacer plate SL 3-ZPL 33/5
- 8 Valve section
- 9 End plate

Coding	a
No designation	6.4
1	6.4
2	18.3

Type	Ports as per ISO 228-1 (BSPP)		
	P	R	LS, M, Y, Z
PSL 45 U../...-3	G 3/4	G 1	G 1/4
PSL 5 U.../...-3	G 1	G 1	G 1/4

PSL 6 UC 22 2/...-3

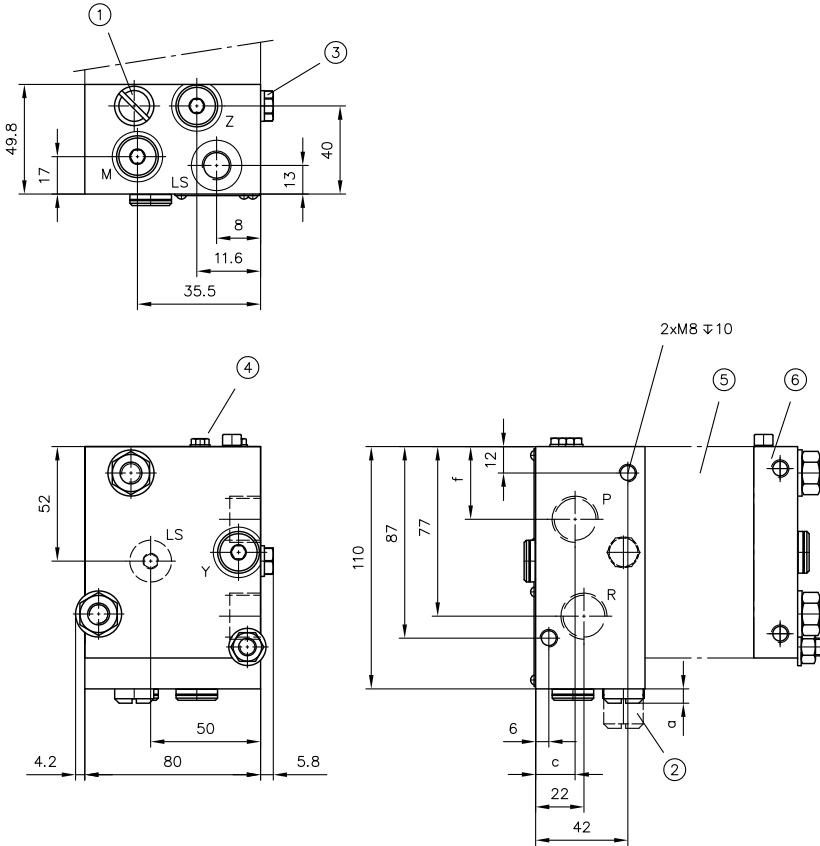


- 1 Internal control oil supply coding 1 or without designation
- 2 Internal control oil supply coding 2
- 3 LS damping
- 4 Pressure-limiting valve
- 5 Idle circulation valve
- 6 Mounting point for additional valve for switching the idle circulation valve
- 7 Valve section
- 8 End plate

Coding	a
No designation	3.9
1	3.9
2	15.8

Type	Ports as per ISO 228-1 (BSPP)	
	P, R	LS, Z, M, Y
PSL 6 UC 22 2/...-3	G 1 1/4	G 1/4

PSV 3...-3
 PSV 4...-3
 PSV UNF 4...-3



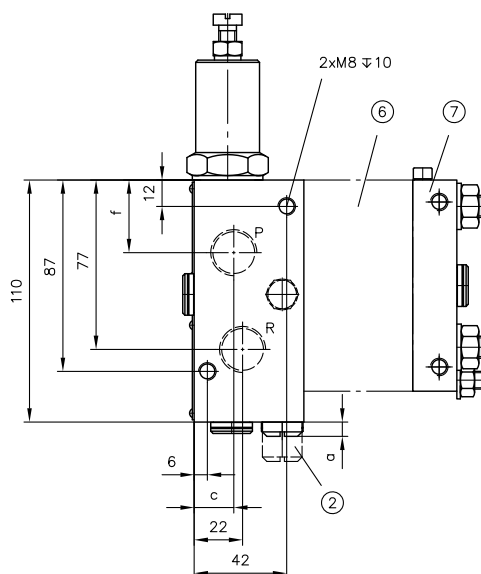
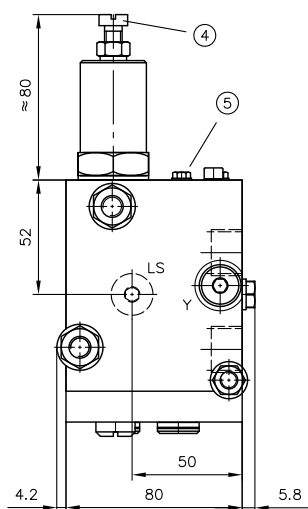
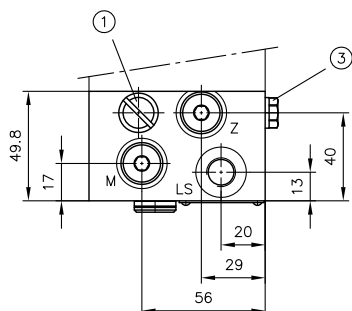
- 1 Internal control oil supply coding 1 or without designation
- 2 Internal control oil supply coding 2
- 3 LS damping
- 4 Mounting point for additional valve for LS relief or LS pressure limitation
- 5 Valve section
- 6 End plate

Type	c	f	Coding	a
PSV 3...-3	18	33	No designation	6.4
PSV 4...-3	21	33	1	6.4
PSV UNF 4...-3	21	30.5	2	18.3

Ports as per ISO 228-1 (BSPP) or SAE J 514

	P, R	LS, M, Y, Z
PSV 3...-3	G 1/2	G 1/4
PSV 4...-3	G 3/4	G 1/4
PSV UNF 4...-3	SAE-12 (1 1/16-12 UN-2B)	SAE-4 (7/16-20 UNF-2B)

PSV 3.../...-3
 PSV 4.../...-3
 PSV UNF 4.../...-3



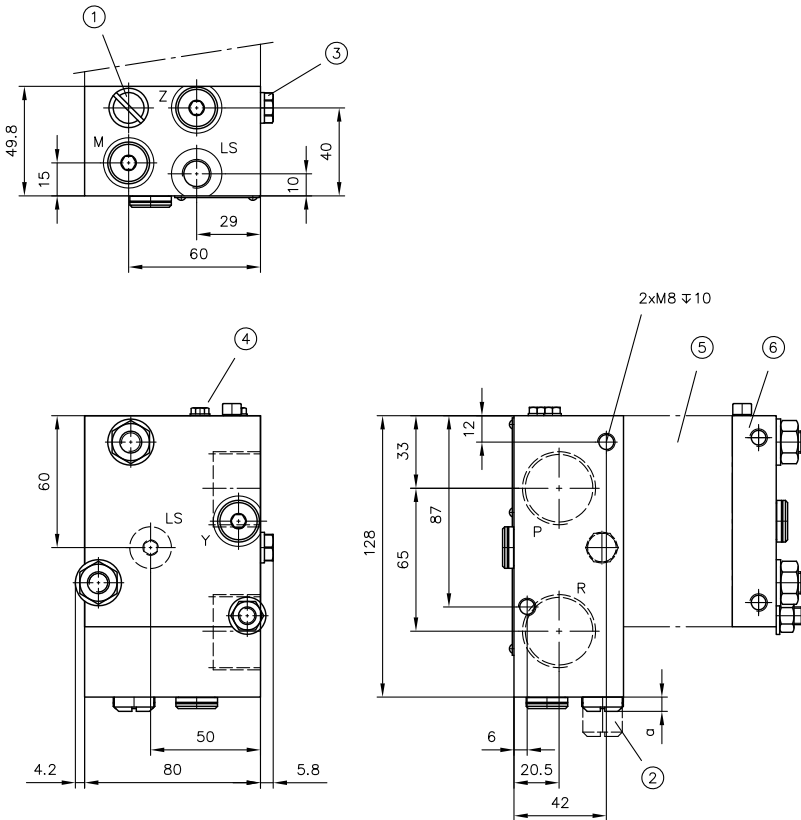
- 1 Internal control oil supply coding 1 or without designation
- 2 Internal control oil supply coding 2
- 3 LS damping
- 4 Mounting point for additional valve for LS relief or LS pressure limitation
- 5 Valve section
- 6 End plate

Type	c	f	Coding	a
PSV 3.../...-3	18	33	No designation	6.4
PSV 4.../...-3	21	33	1	6.4
PSV UNF 4.../...-3	21	30.5	2	18.3

Ports as per ISO 228-1 (BSPP) or SAE J 514

	P, R	LS, M, Y, Z
PSV 3.../...-3	G 1/2	G 1/4
PSV 4.../...-3	G 3/4	G 1/4
PSV UNF 4.../...-3	SAE-12 (1 1/16-12 UN-2B)	SAE-4 (7/16-20 UNF-2B)

PSV 5...-3

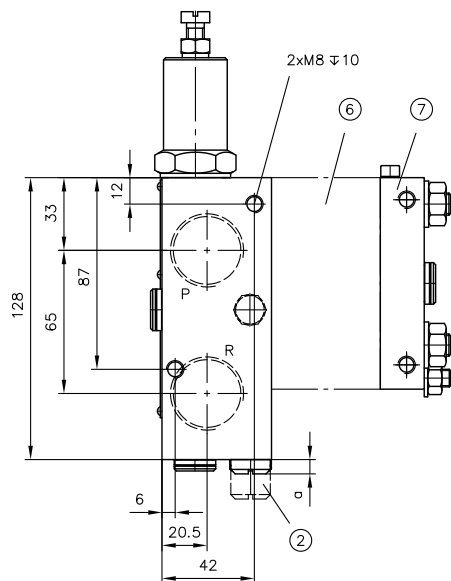
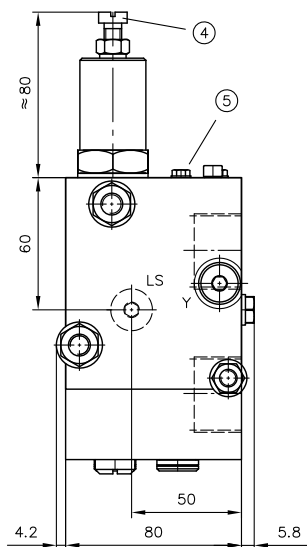
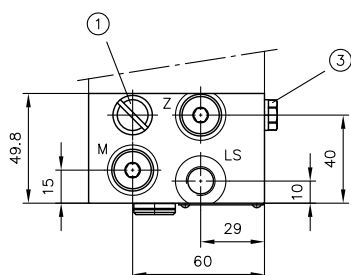


- 1 Internal control oil supply coding 1 or without designation
- 2 Internal control oil supply coding 2
- 3 LS damping
- 4 Mounting point for additional valve for LS relief or LS pressure limitation
- 5 Valve section
- 6 End plate

Coding	a
No designation	6.4
1	6.4
2	18.3

Type	Ports as per ISO 228-1 (BSPP)	
	P, R	LS, M, Y, Z
PSV 5...-3	G 1	G 1/4

PSV 5.../...-3

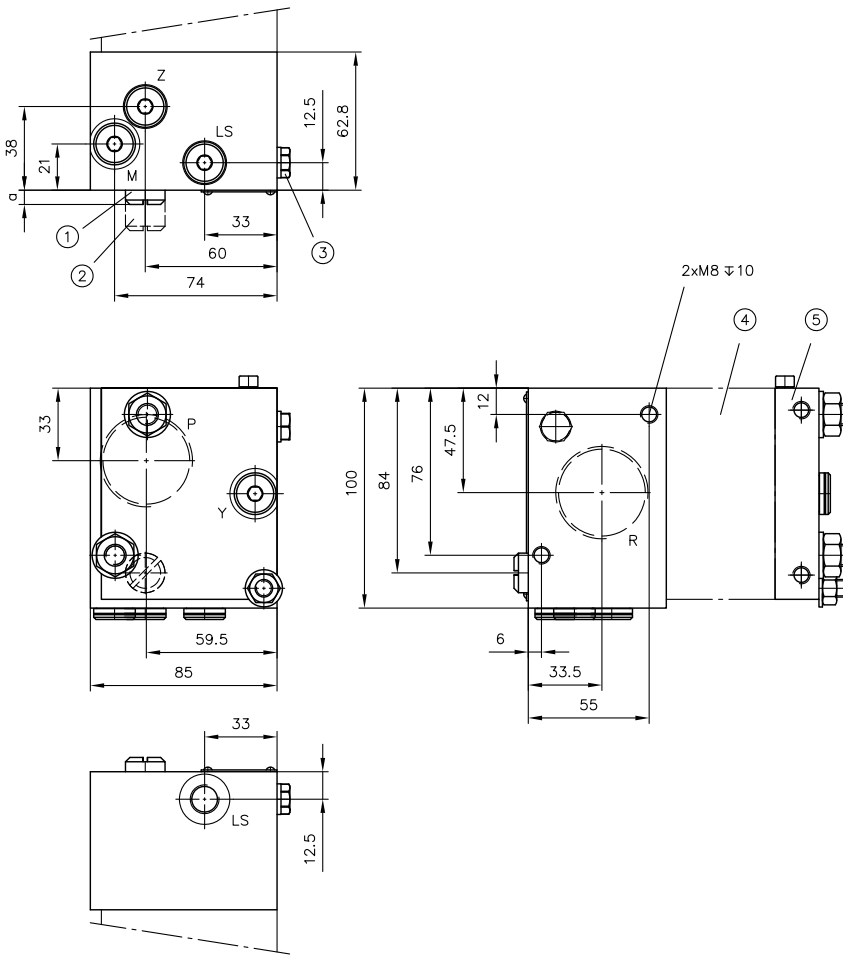


- 1 Internal control oil supply coding 1 or without designation
- 2 Internal control oil supply coding 2
- 3 LS damping
- 4 Pressure-limiting valve
- 5 Mounting point for additional valve for LS relief or LS pressure limitation
- 6 Valve section
- 7 End plate

Coding	a
No designation	6.4
1	6.4
2	18.3

Type	Ports as per ISO 228-1 (BSPP)	
	P, R	LS, M, Y, Z
PSV 5.../...-3	G 1	G 1/4

PSV 6...-3

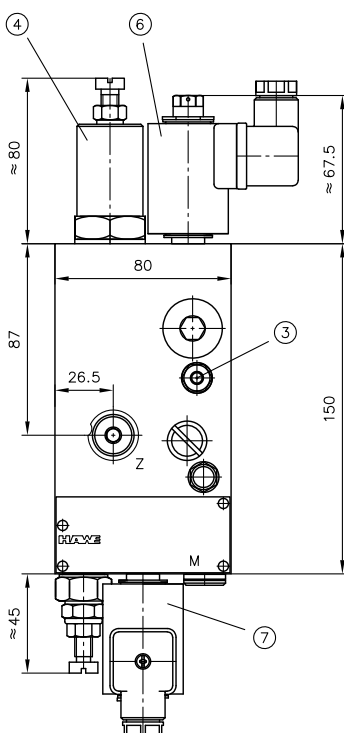
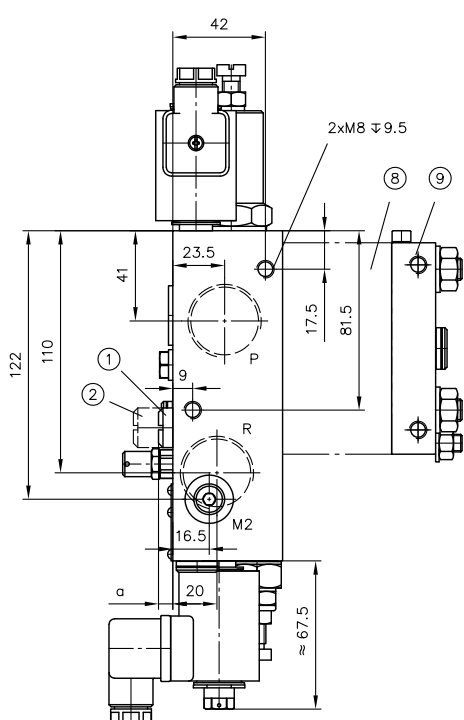
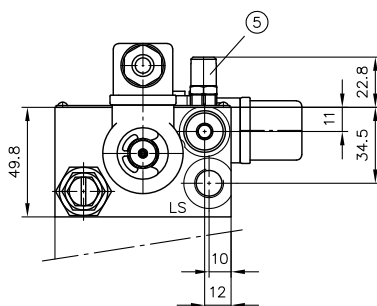


- 1 Internal control oil supply coding 1 or without designation
- 2 Internal control oil supply coding 2
- 3 LS damping
- 4 Valve section
- 5 End plate

Coding	a
No designation	6.4
1	6.4
2	18.3

Type	Ports as per ISO 228-1 (BSPP)	
	P, R	LS, M, Y, Z
PSV 6..-3	G 1 1/4	G 1/4

PSV 5 N...-3
PSV UNF 5 N...-3

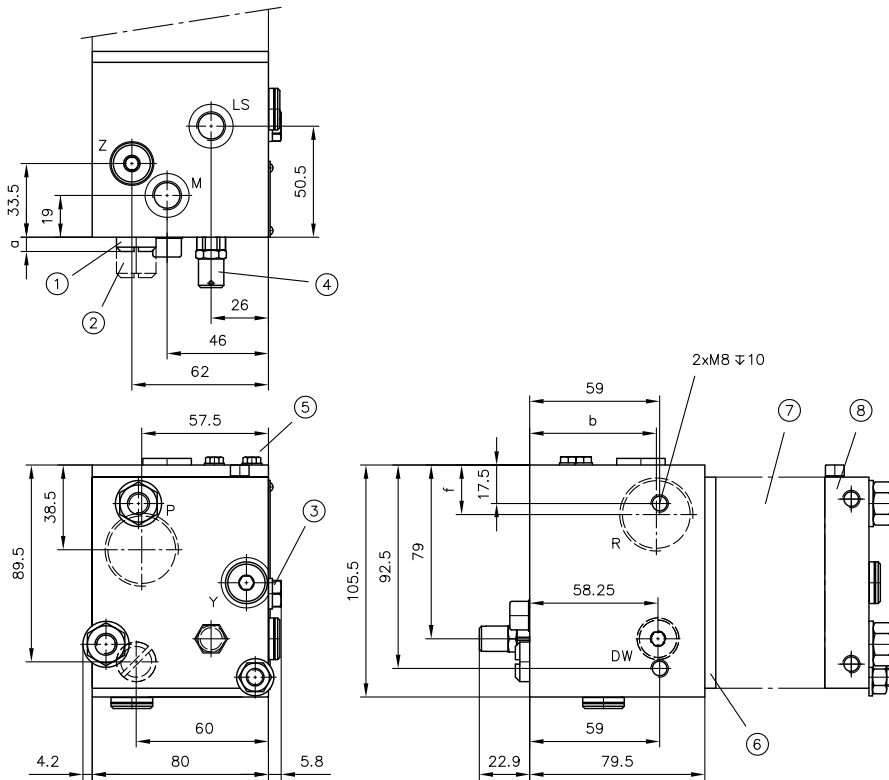


- 1 Internal control oil supply coding 1 or without designation
- 2 Internal control oil supply coding 2
- 3 LS damping
- 4 Pressure-limiting valve
- 5 LS pressure-limiting valve
- 6 2/2-way directional valve for switching P-gallery shut-off
- 7 Optional: LS release valve
- 8 Valve section
- 9 End plate

Coding	a
No designation	6.4
1	6.4
2	18.3

Type	Ports as per ISO 228-1 (BSPP) or SAE J 514		
	P, R	LS, M, Z	M2
PSV 5 N...-3	G 1	G 1/4	G 1/8
PSV UNF 5 N...-3	SAE-16 (1 5/16-12 UN-2B)	SAE-4 (7/16-20 UNF-2B)	--

PSM 5.../...-3
PSM UNF 4.../...-3



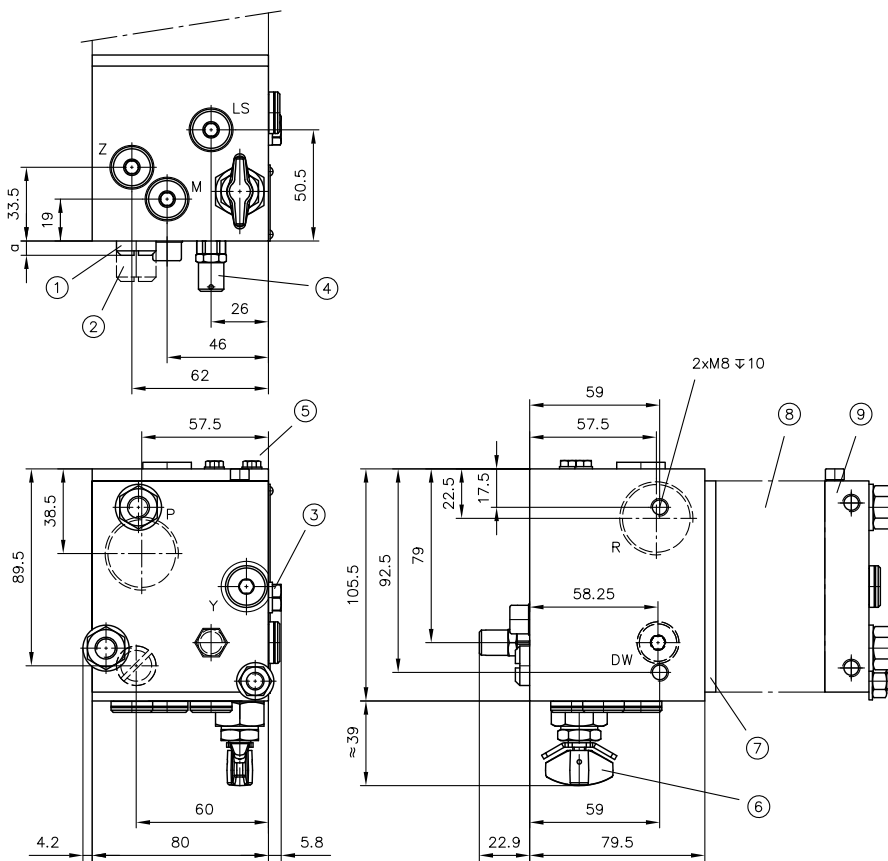
- 1 Internal control oil supply coding 1 or without designation
- 2 Internal control oil supply coding 2
- 3 LS damping
- 4 Pressure-limiting valve
- 5 Mounting point for additional valve for LS relief or LS pressure limitation
- 6 Spacer plate SL 3-ZPL 33/5
- 7 Valve section
- 8 End plate

Type	b	f	Coding	a
PSM 5.../...-3	57.5	22.5	No designation	6.4
PSM UNF 4.../...-3	53.5	24.5	1	6.4
			2	18.3

Ports as per ISO 228-1 (BSPP) or SAE J 514

	P, R	DW, LS, M, Y, Z
PSM 5...-...-3	G 1	G 1/4
PSM UNF 4.../...-3	SAE-12 (1 1/16-12 UN-2B)	SAE-4 (7/16-20 UNF-2B)

PSM 5 L.../...-3



- 1 Internal control oil supply coding 1 or without designation
- 2 Internal control oil supply coding 2
- 3 LS damping
- 4 Pressure-limiting valve
- 5 Mounting point for additional valve for LS relief or LS pressure limitation
- 6 3/2-way directional valve for mechanical switchover between open centre and closed centre
- 7 Spacer plate SL 3-ZPL 33/5
- 8 Valve section
- 9 End plate

Coding	a
No designation	6.4
1	6.4
2	18.3

Type	Ports as per ISO 228-1 (BSPP)	
	P, R	LS, M, Y, Z
PSM 5 L.../...-3	G 1	G 1/4

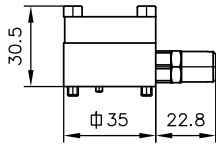
Additional valves for LS relief or LS pressure limitation on connection block

as per ["Table 7: LS relief or LS pressure limitation"](#)

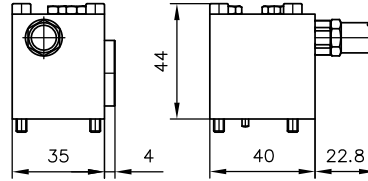
No designation



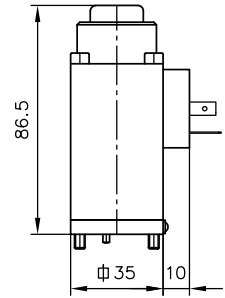
Coding X...



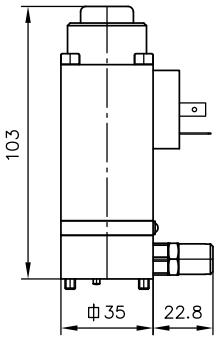
Coding VX...



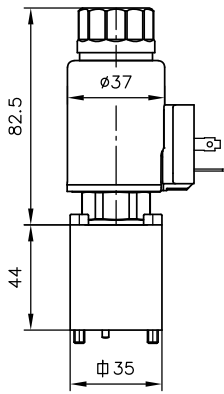
Coding F, D



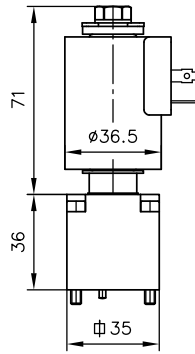
Coding F..., D...



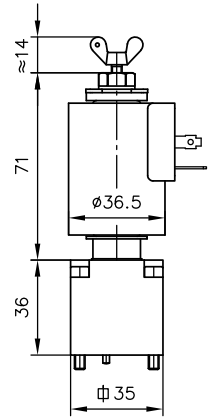
Coding F BVE, D BVE



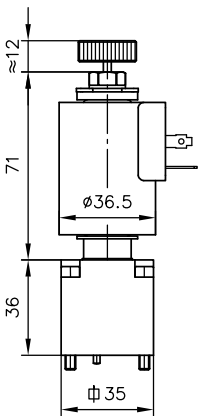
Coding V, Z



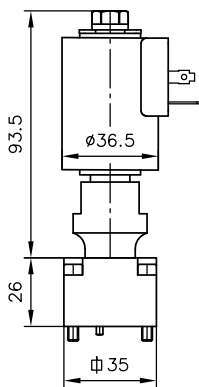
Coding ZM



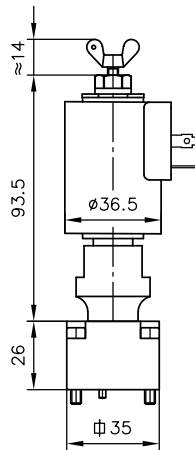
Coding ZP



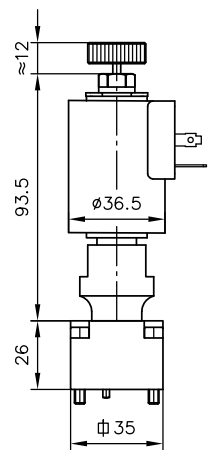
Coding VA, ZA



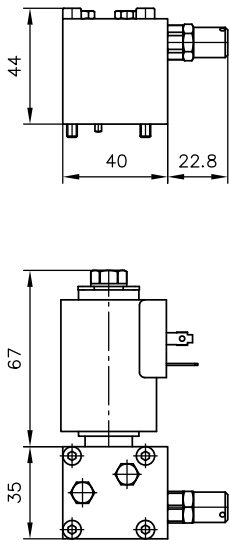
Coding ZAM



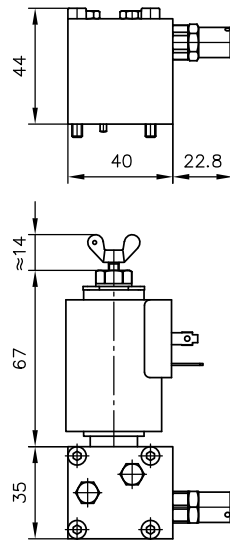
Coding ZAP



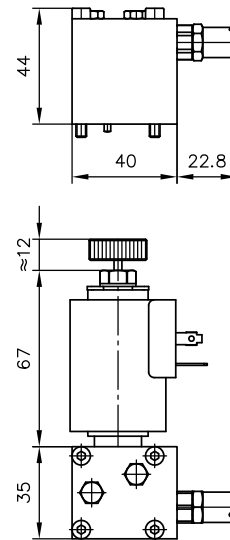
Coding **VD...**, **ZD...**



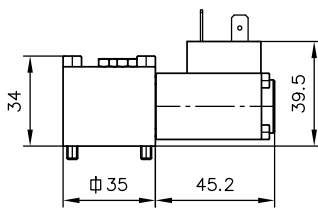
Coding **ZDM...**



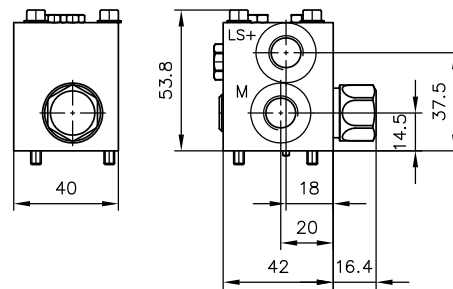
Coding **ZDP...**



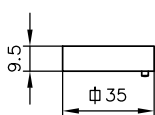
Coding **PA, PB, PC, PD**



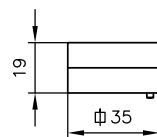
Coding **Z ADM .**



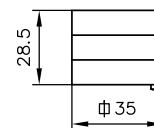
Coding **X9**



Coding **X18**



Coding **X27**

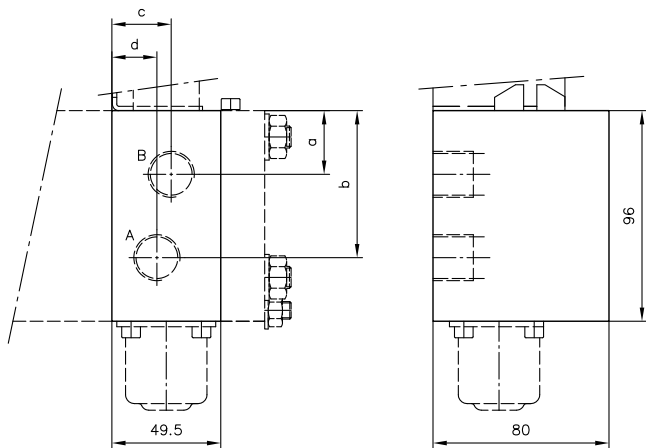


4.2 Valve section

4.2.1 Directional valve section

Directional valve section with integrated consumer ports

(coding 3, 4, UNF 3 and UNF 4 as per ["Table 10: Consumer ports "](#))

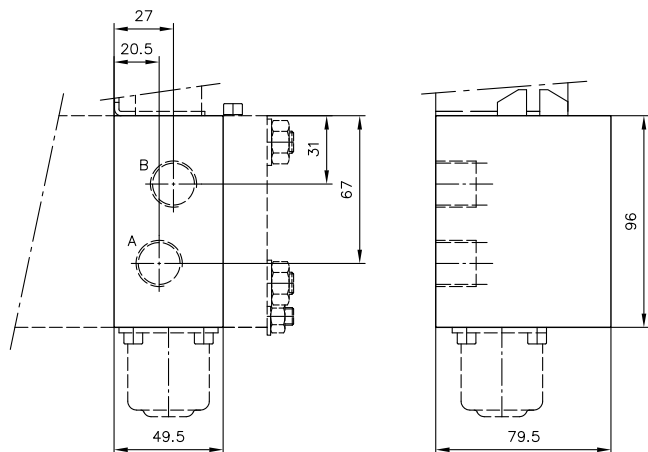


Coding	Ports A and B as per ISO 228-1 (BSPP) or SAE J 514	a	b	c	d
3	G 1/2	29	67	27	20.5
4	G 3/4	27	69	31.5	21.5
UNF 3	SAE-10 (7/8-14 UNF-2B)	29	67	27	20.5
UNF 4	SAE-12 (1 1/16-12 UN-2B)	--	69	--	21.5

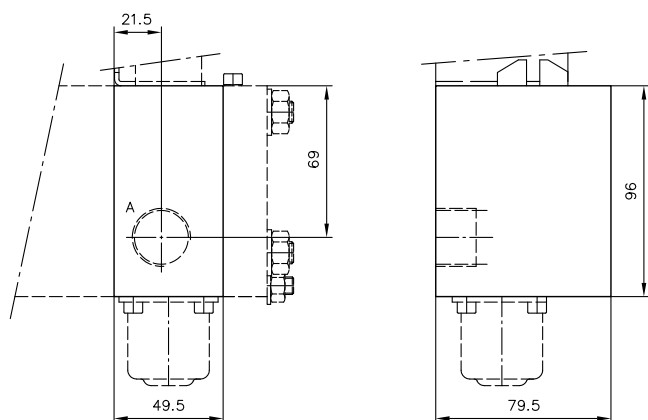
Pre-selector directional valve section with integrated ports

(coding 8 as per "Table 11: Valve section, 2-way controller ")

Coding 38



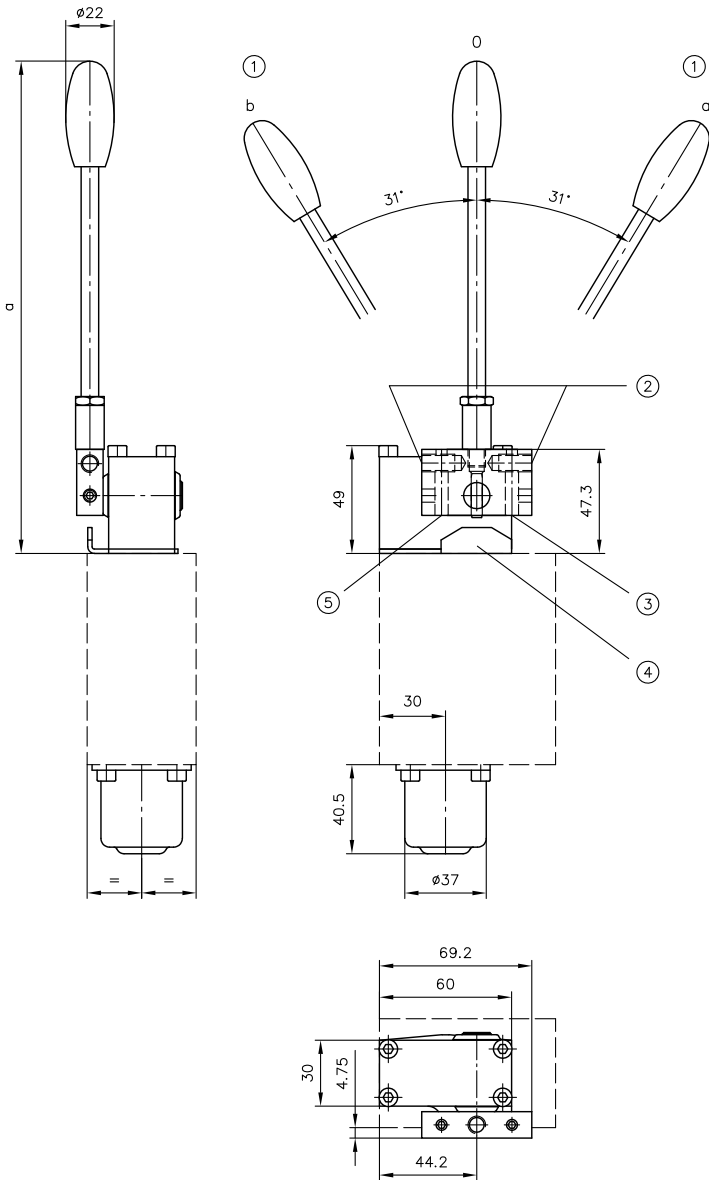
Coding 48, UNF 48



Coding	Ports A and B as per ISO 228-1 (BSPP) or SAE J 514
38	G 1/2
48	G 3/4
UNF 48	SAE-12 (1 1/16-12 UNF-2B)

Directional valve section with manual actuation

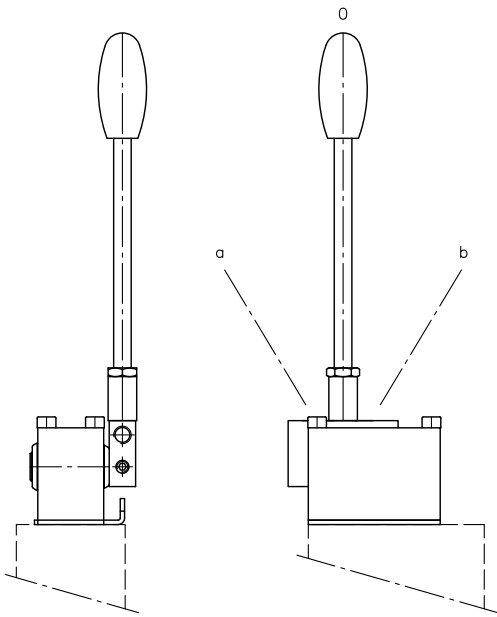
Actuation A, C, D



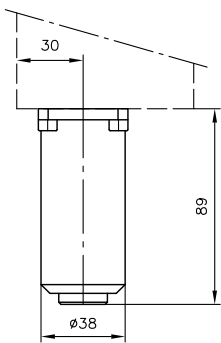
- 1 Switching position 0, a and b
- 2 Alternative mounting position for hand lever (thread M8, 15 mm deep)
- 3 Stroke limitation for A
- 4 Shim to act as stop for stroke limitation
- 5 Stroke limitation for B

Coding	a
A, C, D (standard lever arm)	221.5
A2, C2, D2 (stub lever arm)	147.5

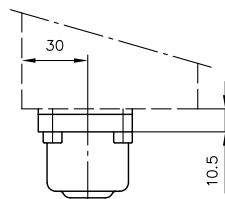
Lever housing can be mounted offset by 180°. Please state so explicitly when ordering.



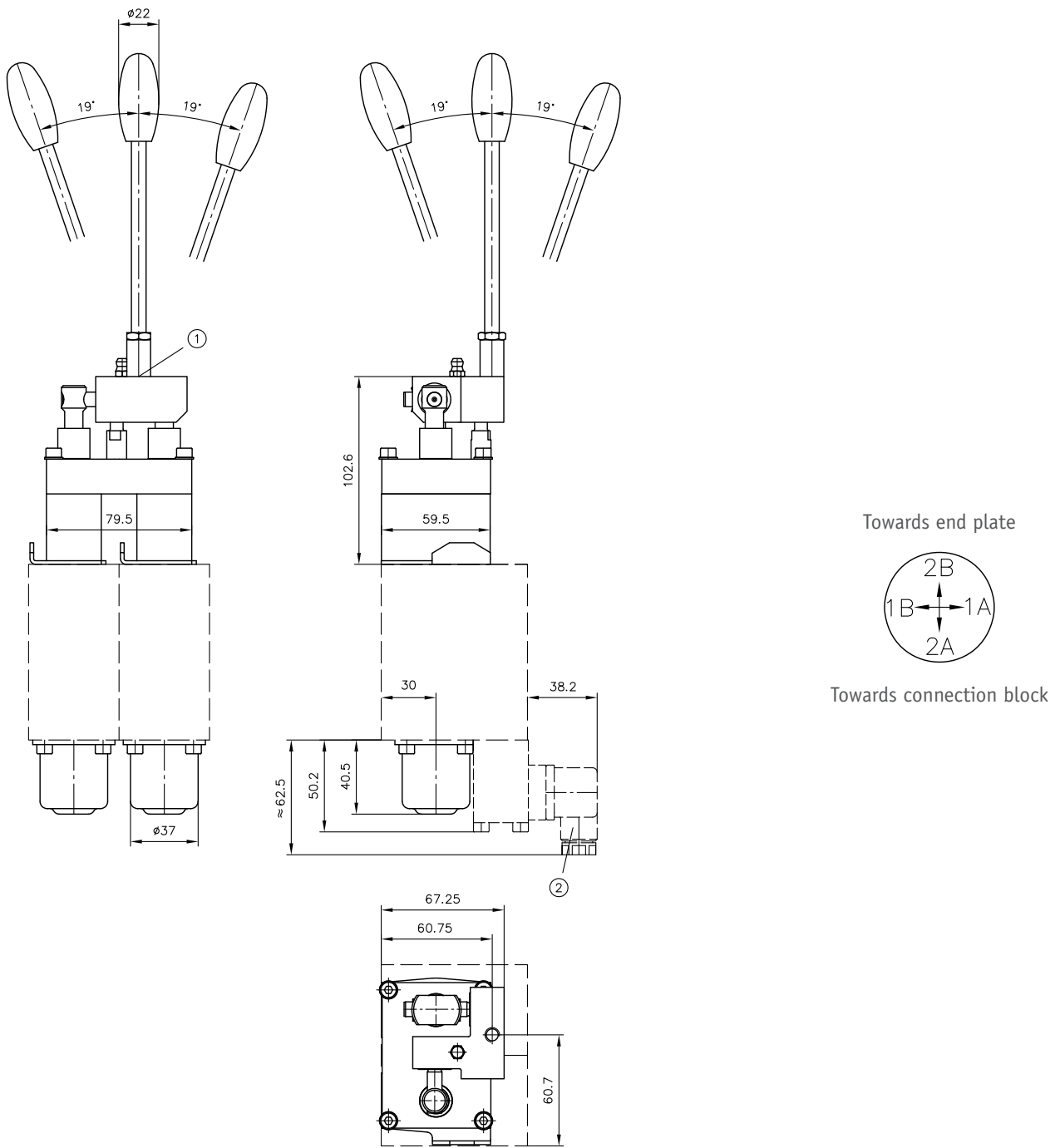
Actuation **AR**



Actuation **AG**



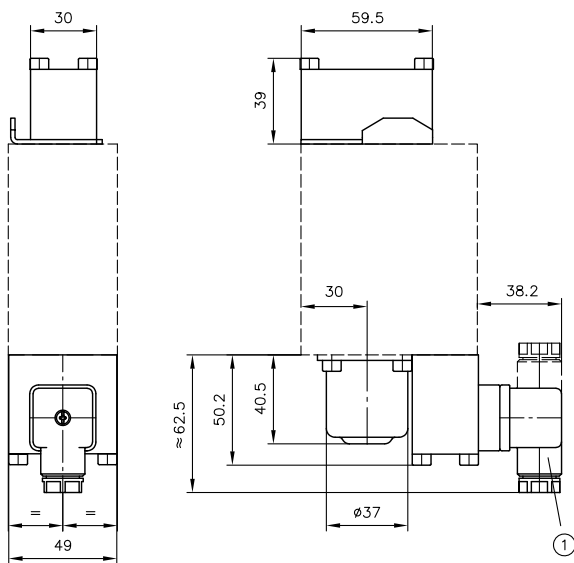
Actuation K, K 12, EK, EK 12



- 1 Coding K: M8 thread, with hand lever
Coding K 12: M12 thread, without hand lever
- 2 Solenoid for coding EK and EK 12

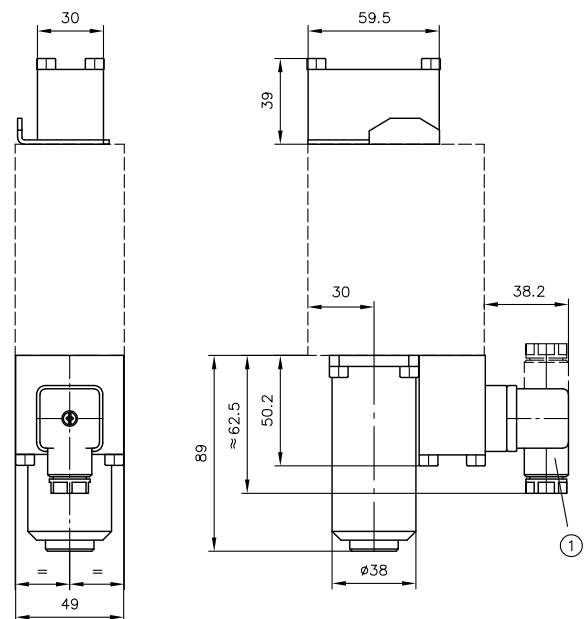
Directional valve section with electro-hydraulic actuation

Actuation EI



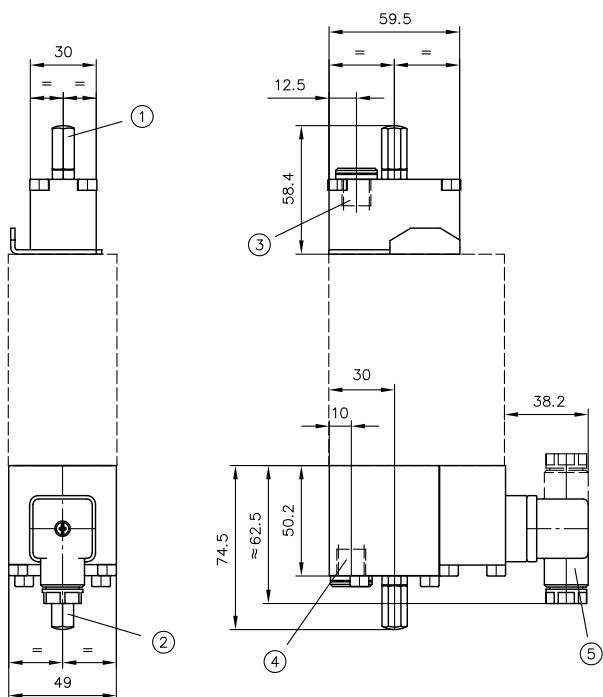
1 Male connector can be mounted offset by 180° (depends on version)

Actuation ER



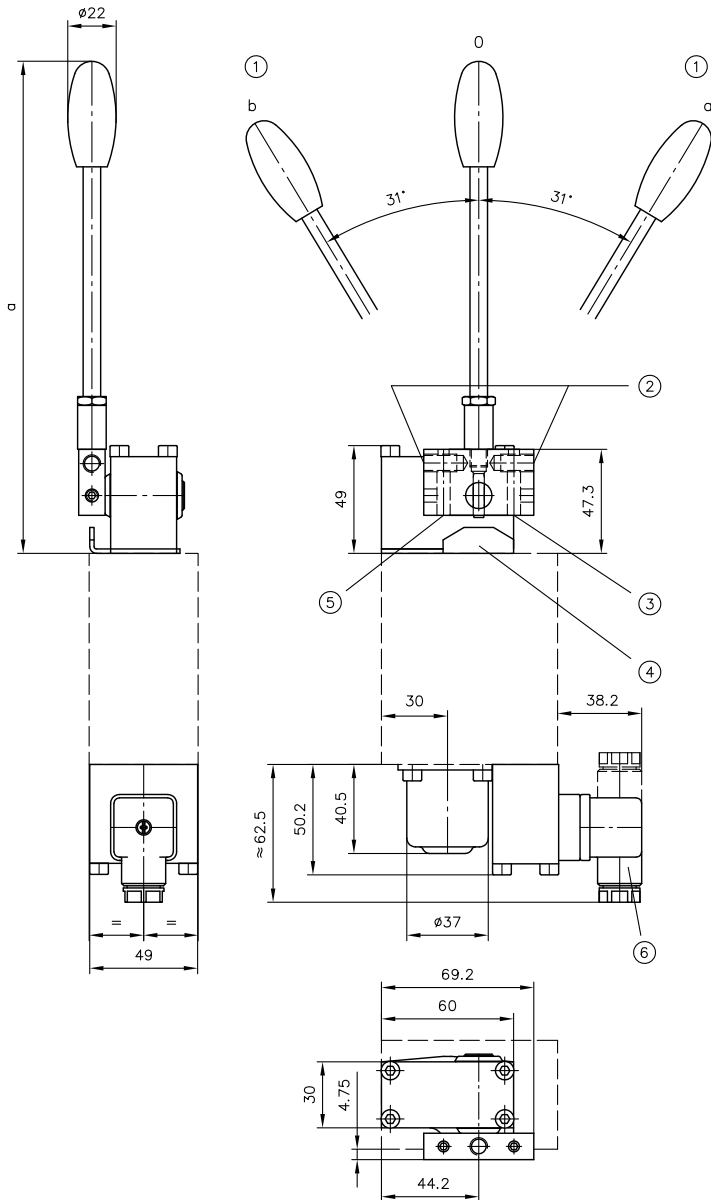
1 Male connector can be mounted offset by 180° (depends on version)

Actuation EM



- 1 Stroke limitation for A
- 2 Stroke limitation for B
- 3 Measurement fitting in switching position a
- 4 Measurement fitting in switching position b
- 5 Male connector can be mounted offset by 180° (depends on version)

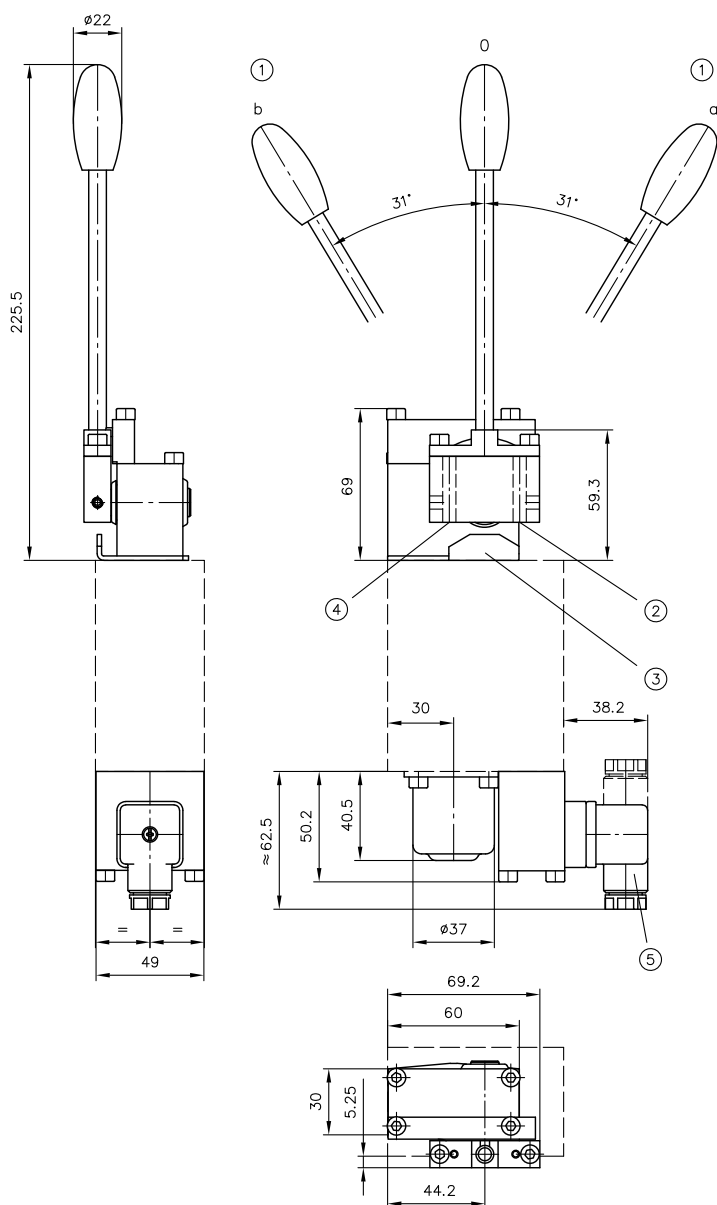
Actuation EA



- 1 Switching position 0, a and b
- 2 Alternative mounting position for hand lever (thread M8, 15 mm deep)
- 3 Stroke limitation for A
- 4 Shim to act as stop for stroke limitation
- 5 Stroke limitation for B
- 6 Male connector can be mounted offset by 180° (depends on version)

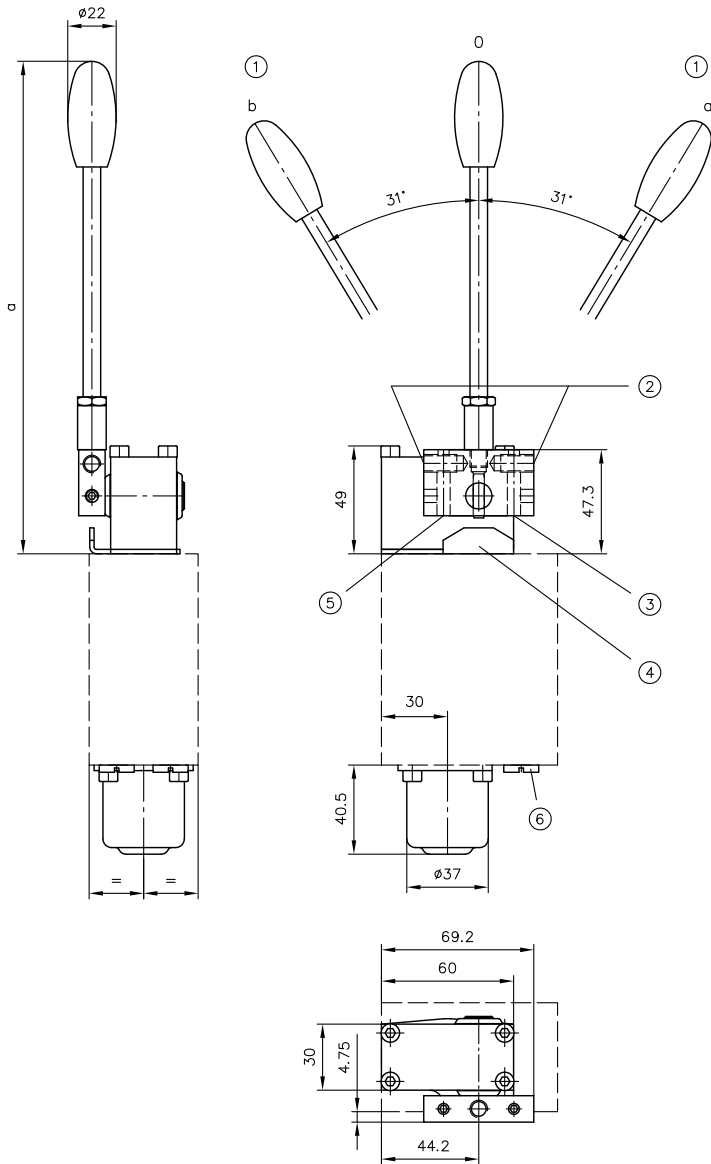
Coding	a
EA (standard lever arm)	221.5
EA2 (stub lever arm)	147.5

Actuation EIN



- 1 Switching position 0, a and b
- 2 Stroke limitation for A
- 3 Shim to act as stop for stroke limitation
- 4 Stroke limitation for B
- 5 Male connector can be mounted offset by 180° (depends on version)

Actuation **EOA**

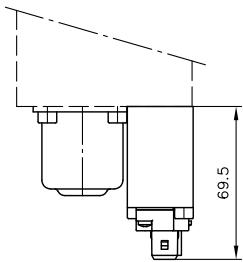


- 1 Switching position 0, a and b
- 2 Alternative mounting position for hand lever (thread M8, 15 mm deep)
- 3 Stroke limitation for A
- 4 Shim to act as stop for stroke limitation
- 5 Stroke limitation for B
- 6 Tapped plugs

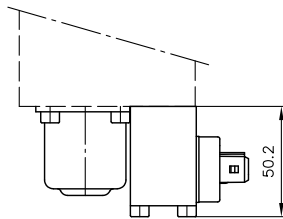
Coding	a
EOA (standard lever arm)	221.5
EOA2 (stub lever arm)	147.5

Solenoid version drawings

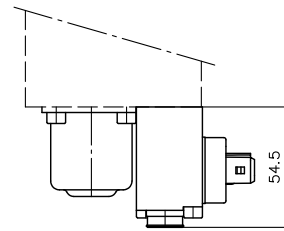
Coding
AMP 12(24) K, AMP 12(24) K 4



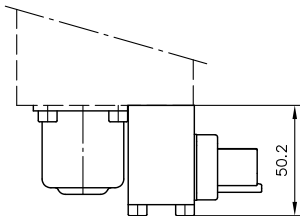
Coding
AMP 12(24) H 4



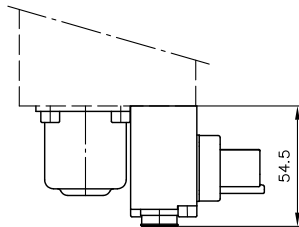
Coding
AMP 12(24) H 4 T



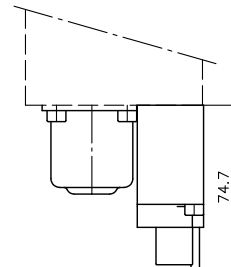
Coding
DT 12(24)



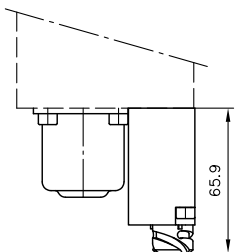
Coding
DT 12(24) T



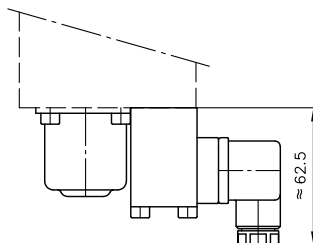
Coding
DT 12(24) K



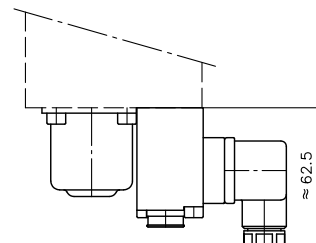
Coding
S 12(24) T



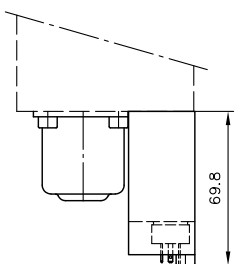
Coding
G 12(24) H 4



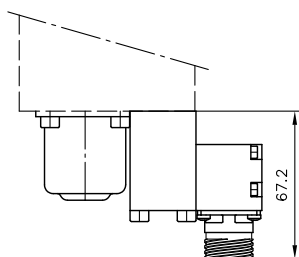
Coding
G 12(24) T



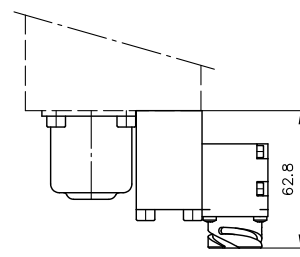
Coding
X 12(24) C, X 12(24) C 4



Coding
DTL 12(24)

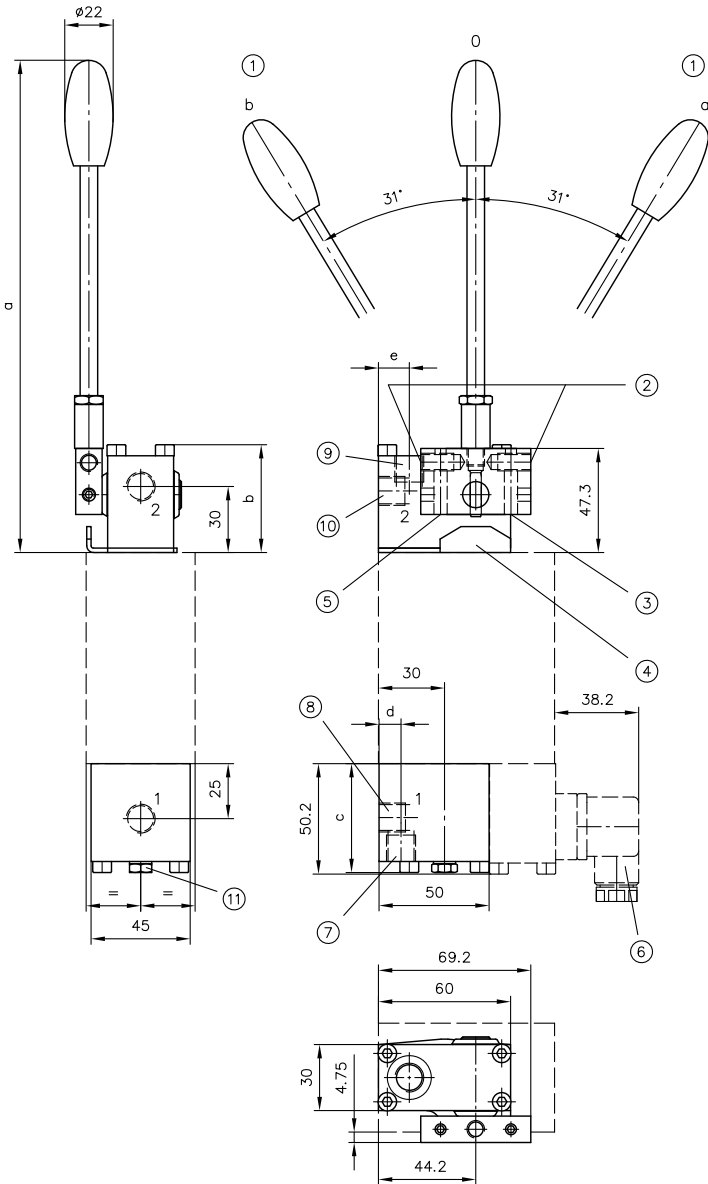


Coding
ITT 12(24)



Directional valve section with hydraulic actuation

Actuation HA (UNF), FA (UNF), EHA (UNF), EFA (UNF), EOHA (UNF), EOFA (UNF)



- 1 Switching position 0, a and b
- 2 Alternative mounting position for hand lever (thread M8, 15 mm deep)
- 3 Stroke limitation for A
- 4 Shim to act as stop for stroke limitation
- 5 Stroke limitation for B
- 6 Solenoid with male connector (for coding E only), male connector can be mounted offset by 180° (depends on version)
- 7 Port 1 for coding F
- 8 Port 1 for coding H
- 9 Port 2 for coding F
- 10 Port 2 for coding H
- 11 for coding HA only

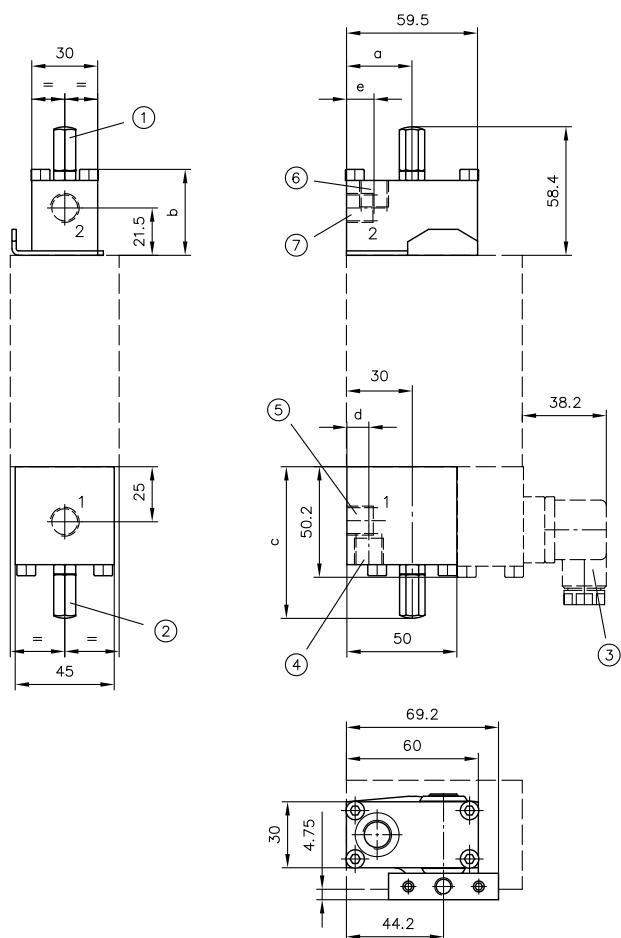
Coding	a
A (standard lever arm)	221.5
A2 (stub lever arm)	147.5

Coding	b	c	d	e
HA, EHA, EOHA HA UNF, EHA UNF, EOHA UNF	49	49.5	--	--
FA, EFA, EOFA	44	55	10	13.8
FA UNF, EFA UNF, EOFA UNF	44	49.5	7	14.8

Ports as per ISO 228-1 (BSPP) or SAE J 514

	1, 2
H, F	G 1/4
H UNF, F UNF	SAE-4 (7/16-20 UNF-2B)

Actuation H (UNF), F (UNF), FI (UNF), EH (UNF), EF (UNF), EFI (UNF), EOH (UNF), EOF (UNF), EOFI (UNF)



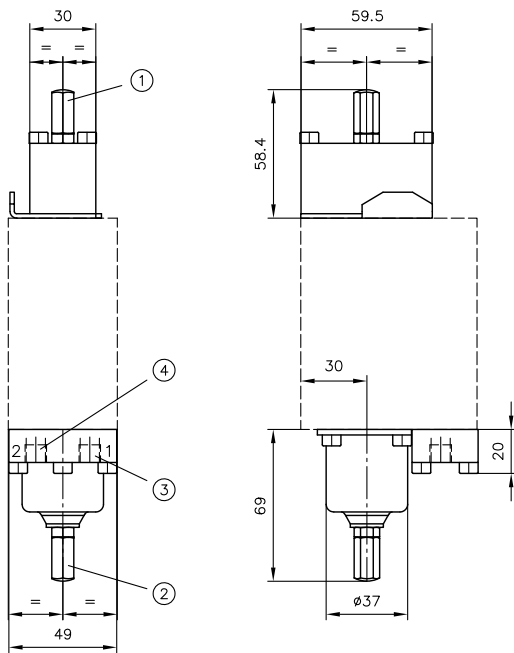
- 1 Stroke limitation for A (not for coding I)
- 2 Stroke limitation for B (not for coding I)
- 3 Solenoid with male connector (for coding E only), male connector can be mounted offset by 180° (depends on version)
- 4 Port 1 for coding F
- 5 Port 1 for coding H
- 6 Port 2 for coding F
- 7 Port 2 for coding H

Coding	a	b	c	d	e
H, EH, EOH H UNF, EH UNF, EOH UNF	29.75	39	68.9	--	--
F, EF, EOF	31	34	74.5	10	12.5
F UNF, EF UNF, EOF UNF	31	34	68.9	7	12
FI, EFI, EOFI	--	34	55	10	12.5
FI UNF, EFI UNF, EOFI UNF	--	34	49.5	7	14.1

Ports as per ISO 228-1 (BSPP) or SAE J 514

	1, 2
H, F	G 1/4
H UNF, F UNF	SAE-4 (7/16-20 UNF-2B)

Actuation **EOZ (UNF)**

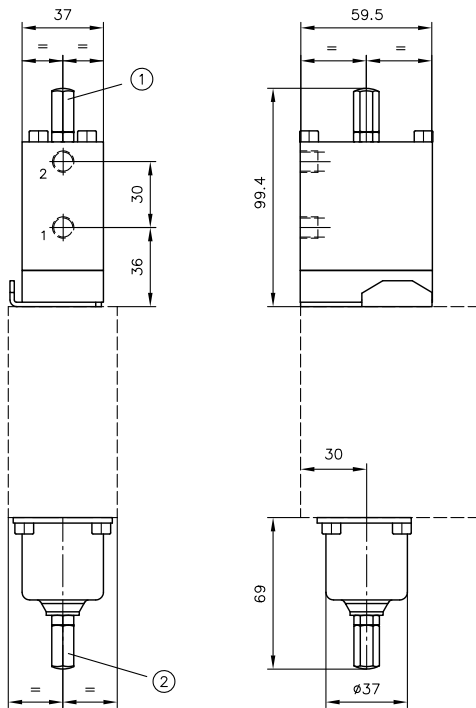


- 1 Stroke limitation for A
- 2 Stroke limitation for B
- 3 Port 1
- 4 Port 2

Coding	Ports as per ISO 228-1 (BSPP) or SAE J 514
	1, 2
EOZ	G 1/8
EOZ UNF	SAE-2 (5/16-24 UNF-2B)

Directional valve section with pneumatic actuation

Actuation P



- 1 Stroke limitation for A
- 2 Stroke limitation for B

Coding

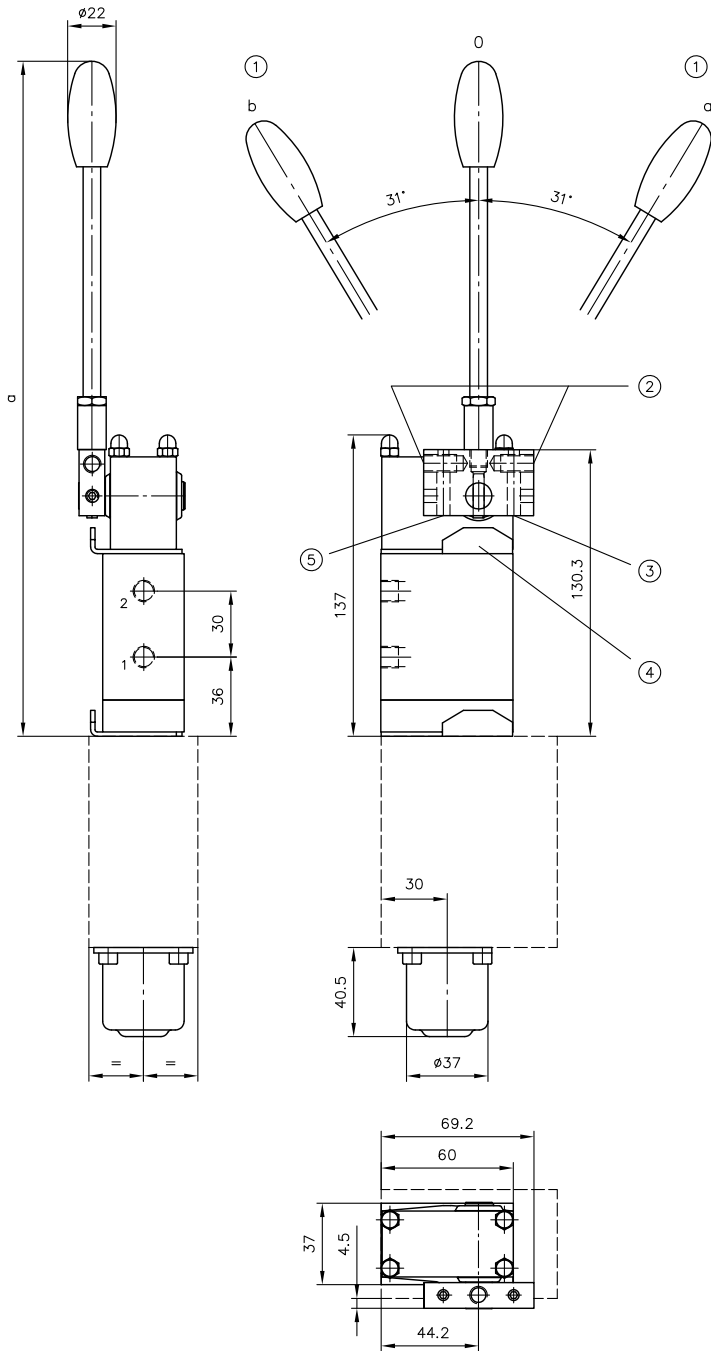
Port as per ISO 228-1 (BSPP)

1, 2

P

G 1/8

Actuation PA



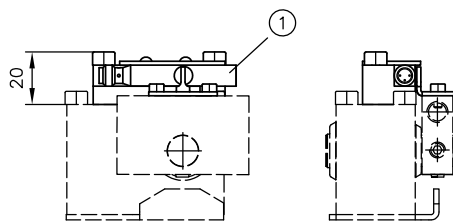
- 1 Switching position 0, a and b
- 2 Alternative mounting position for hand lever (thread M8, 15 mm deep)
- 3 Stroke limitation for A
- 4 Shim to act as stop for stroke limitation
- 5 Stroke limitation for B

Coding	a
A (standard lever arm)	306.8
A2 (stub lever arm)	231

Coding	Port as per ISO 228-1 (BSPP)
	1, 2
PA	G 1/8

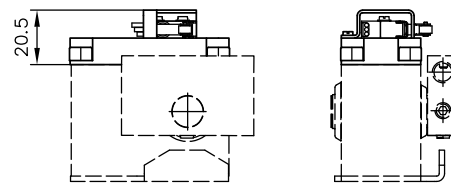
Switching position monitoring, displacement transducer

Coding **N, N1**

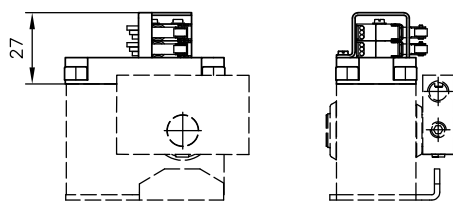


1 Coding N only

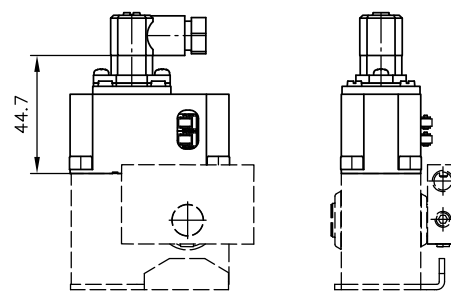
Coding **V, VA, VB**



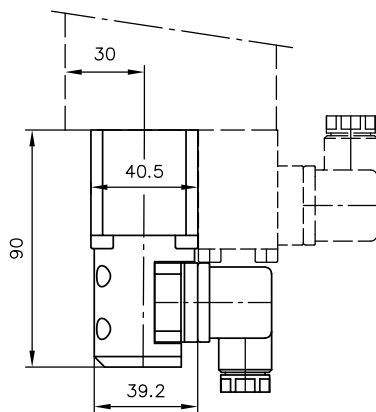
Coding **VC**



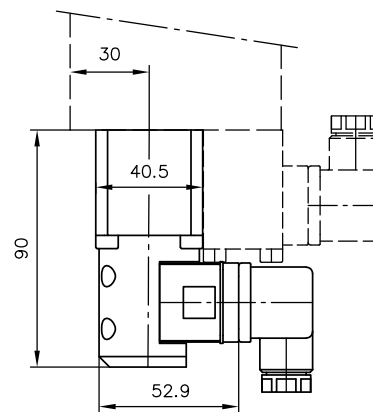
Coding **VCHO, VCHC**



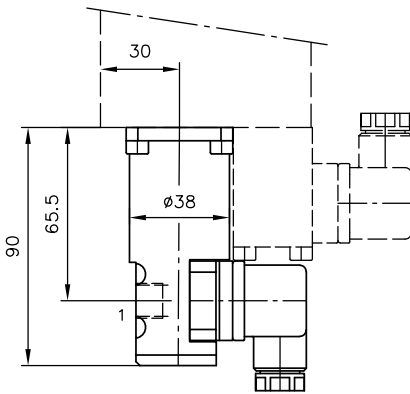
Coding **WA**



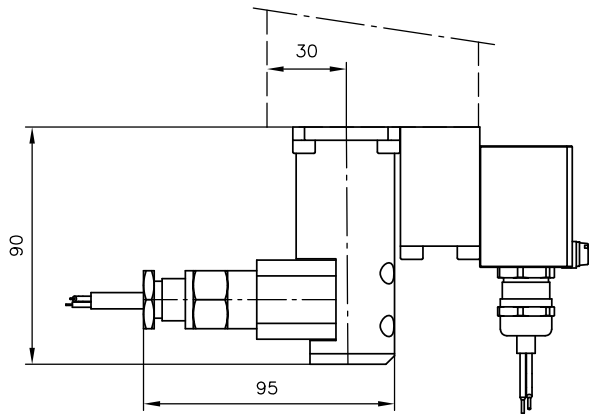
Coding **U**



Coding H...WA



Coding WA-M2FP

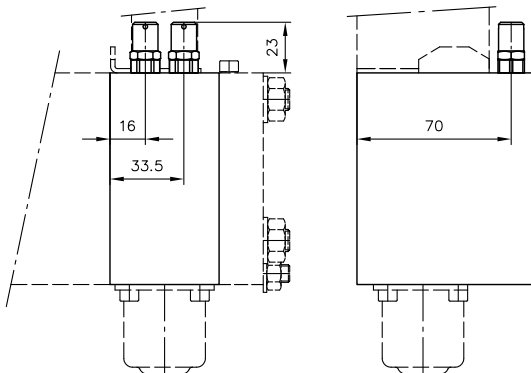


Port as per ISO 228-1 (BSP)

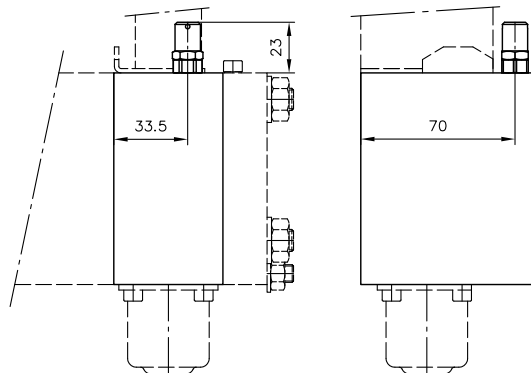
1	G 1/4
---	-------

Directional valve section with LS pressure limitation

Coding AB, A..., B..., A... B...

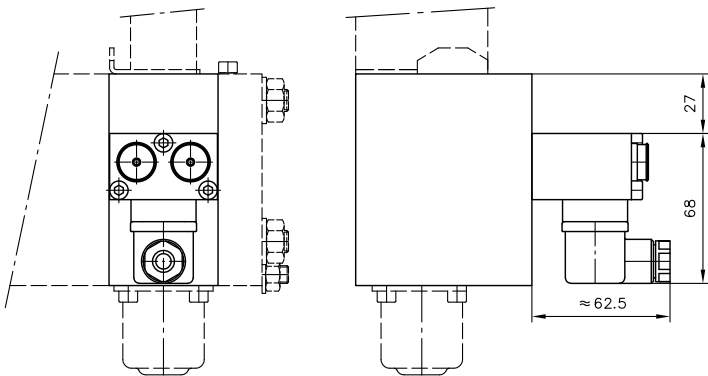


Coding C...



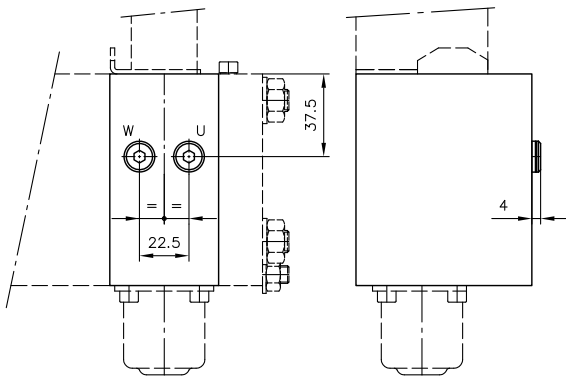
Directional valve section with electric LS relief or LS pressure limitation

Coding F1, F2, F3, FP

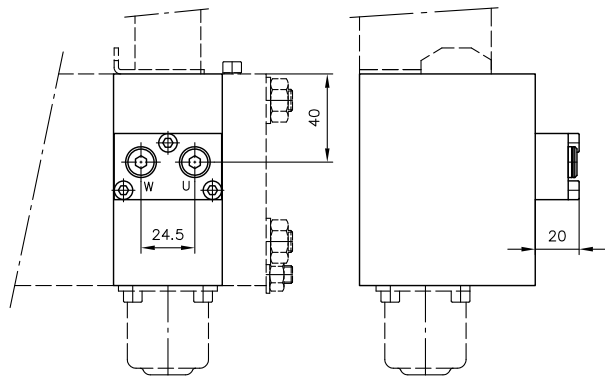


Directional valve section with LS port for external limitation

Coding S

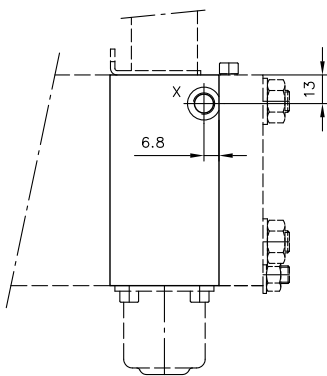


Coding S1, S1 UNF

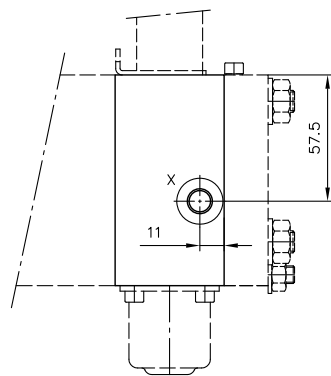


Coding	Ports as per ISO 228-1 (BSPP) or SAE J 514
	U, W
S, S1	G 1/8
S1 UNF	SAE-4 (7/16-20 UNF-2B)

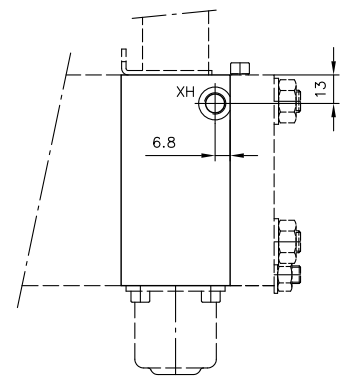
Coding X
(for valve sections with coding 3)



Coding X
(for valve sections with coding UNF 3)



Coding XH

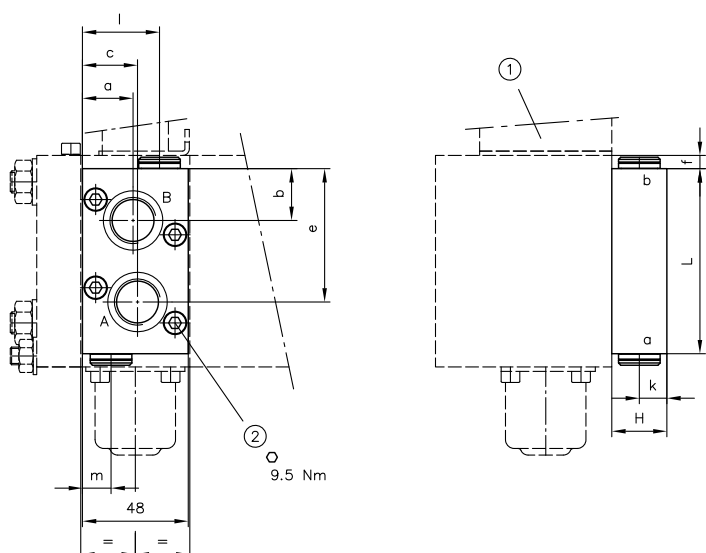


Coding	Ports as per ISO 228-1 (BSPP) or SAE J 514
	X
X (for valve sections with coding 3)	G 1/8
X (for valve sections with coding UNF 3)	SAE-4 (7/16-20 UNF-2B)
XH	G 1/8

4.2.2 Ancillary block

as per [Chapter 2.3.2, "Ancillary block"](#)

/3, /4,
/UNF 12, /UNF 2, /UNF 3, /JIS 3,
/4 AN BN, /UNF 3 AN BN



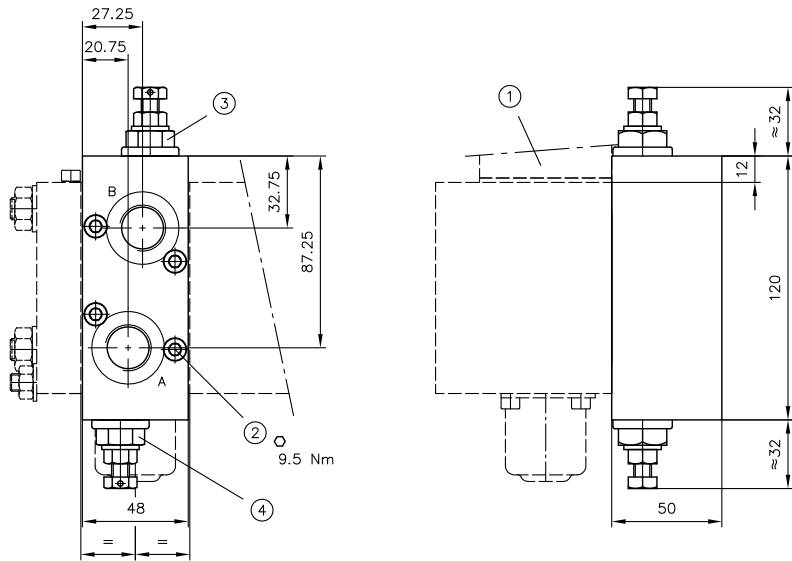
- 1 Directional valve section
 2 Cylinder screws ISO 4762-M6x 25 -A2-70 for coding /3, /UNF 12, /UNF 2
 Cylinder screws ISO 4762-M6x 30 -A2-70 for coding /4, /UNF 3, /JIS 3, /4 AN BN, /UNF 3 AN BN

Coding	H	L	a	b	c	e	f	k	l	m
/3	24.7	84	23	24	25	60	6	12.5	35	13
/4	30	105	27.25	25.25	20.75	79.75	-4.5	16	12	36
/UNF 12	24.7	84	22	25	26	59	6	12.5	30	18
/UNF 2	24.7	84	23.5	21	24.5	63	6	13	36.5	11.5
/UNF 3	29.7	96	26.25	23.75	21.75	72.25	0	17	13.5	34.5
/JIS 3	29.7	96	26.25	23.75	21.75	72.25	0	--	--	--
/4 AN BN	30	105	27.25	25.25	20.75	79.75	-4.5	16	12	36
/UNF 3 AN BN	30	90	27.25	17.75	20.75	72.25	3	--	--	--

Ports as per ISO 228-1 (BSPP) or SAE J 514 or JIS B 2351

	A, B	a, b
/3	G 1/2	G 1/4
/4	G 3/4	G 1/4
/UNF 12	SAE-6 (9/16-18 UNF-2B)	SAE-4 (7/16-20 UNF-2B)
/UNF 2	SAE-8 (3/4-16 UNF-2B)	SAE-4 (7/16-20 UNF-2B)
/UNF 3	SAE-10 (7/8-14 UN-2B)	SAE-4 (7/16-20 UNF-2B)
/JIS 3	JIS G 1/2	--
/4 AN BN	G 3/4	G 1/4
/UNF 3 AN BN	SAE-10 (7/8-14 UN-2B)	--

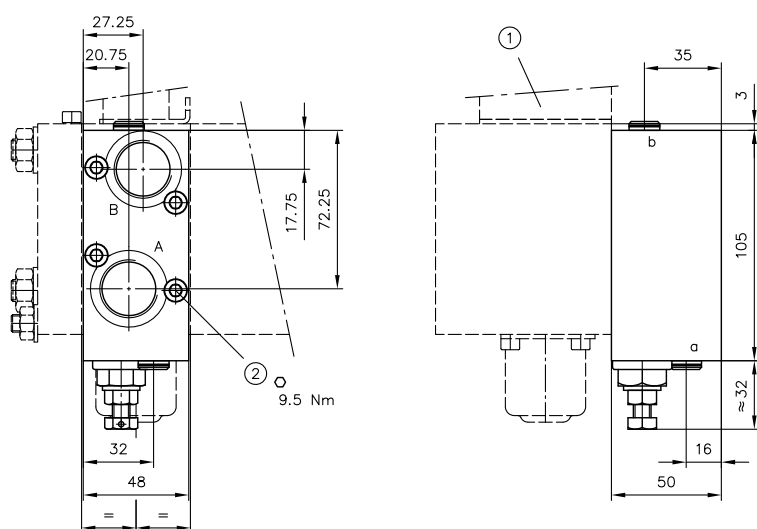
/3 AS.. BS..
/4 AS.. BS..
/UNF 3 AS.. BS..



- 1 Directional valve section
- 2 Cylinder screws ISO 4762-M6x50-A2-70
- 3 Pressure setting A-side
- 4 Pressure setting B-side

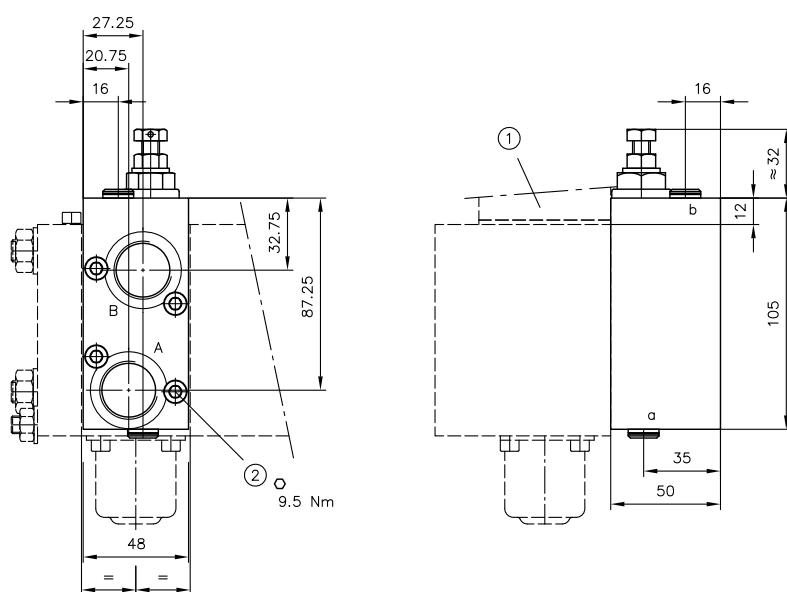
Coding	Ports as per ISO 228-1 (BSPP) or SAE J 514
	A, B
/3 AS.. BS..	G 1/2
/4 AS.. BS..	G 3/4
/UNF 3 AS.. BS..	SAE-10 (7/8-14 UN-2B)

/4 A...



- 1 Directional valve section
- 2 Cylinder screws ISO 4762-M6x50-A2-70

/4 B...



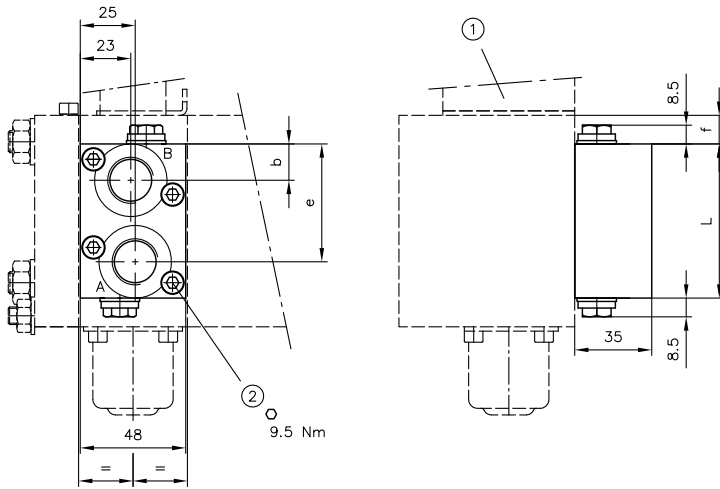
- 1 Directional valve section
- 2 Cylinder screws ISO 4762-M6x50-A2-70

Coding

Ports as per ISO 228-1 (BSPP)

	A, B	a, b
/4 A...	G 3/4	G 1/8
/4 B...	G 3/4	G 1/8

/31 AS... BS...
/31 AN... BN...

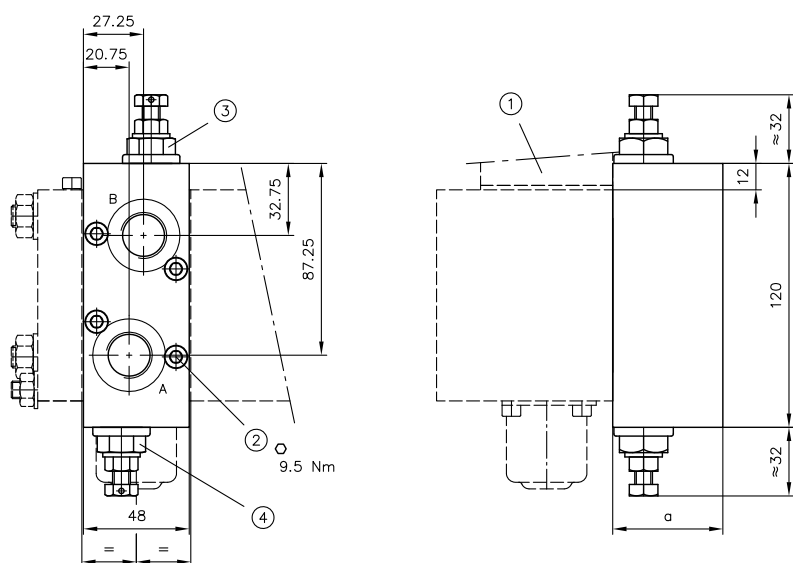


- 1 Directional valve section
2 Cylinder screws ISO 4762-M6x35-A2-70

Coding	L	b	e	f
/31 AS... BS...	70	16.5	53.5	13
/31 AN... BN...	100	31.5	68.5	2

Ports as per ISO 228-1 (BSPP)	
A, B	
/31 AS... BS...	G 1/2
/31 AN... BN...	G 1/2

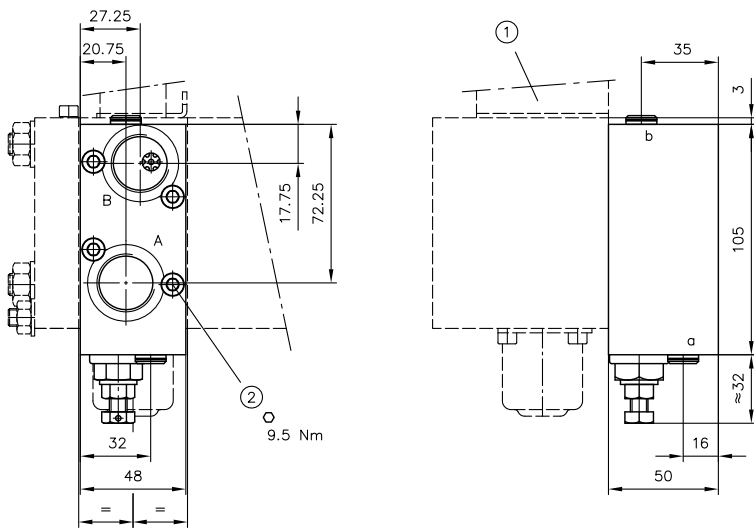
/3 AN.. BN..
/4 AN.. BN..
/44 AN.. BN..
/UNF 3 AN.. BN..



- 1 Directional valve section
- 2 Cylinder screws ISO 4762-M6x50-A2-70 for coding /3(4, UNF 3) AN.. BN..
Cylinder screws ISO 4762-M6x60-A2-70 for coding /44 AN.. BN..
- 3 Pressure setting B-side
- 4 Pressure setting A-side

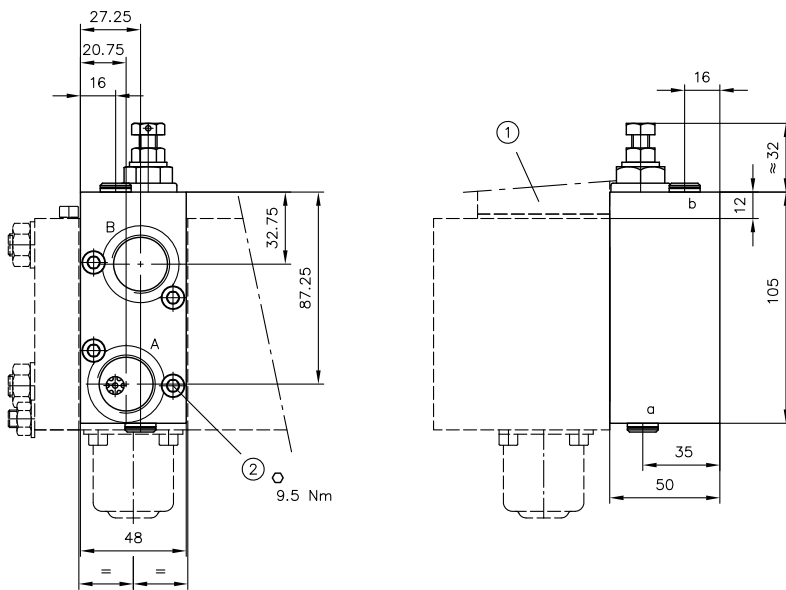
Coding	a
/3 AN.. BN..	
/4 AN.. BN..	50
/UNF 3 AN.. BN..	
/44 AN.. BN..	60
Ports as per ISO 228-1 (BSPP) or SAE J 514	
A, B	
/3 AN.. BN..	G 1/2
/4 AN.. BN.. /44 AN.. BN..	G 3/4
/UNF 3 AN.. BN..	SAE-10 (7/8-14 UN-2B)

/4 AN...



- 1 Directional valve section
- 2 Cylinder screws ISO 4762-M6x50-A2-70

/4 BN...



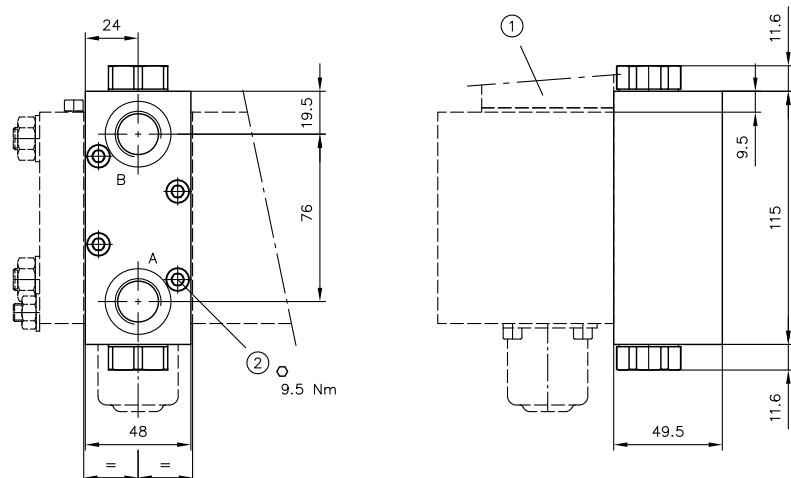
- 1 Directional valve section
- 2 Cylinder screws ISO 4762-M6x50-A2-70

Coding

Ports as per ISO 228-1 (BSPP)

	A, B	a, b
/4 AN...	G 3/4	G 1/8
/4 BN...	G 3/4	G 1/8

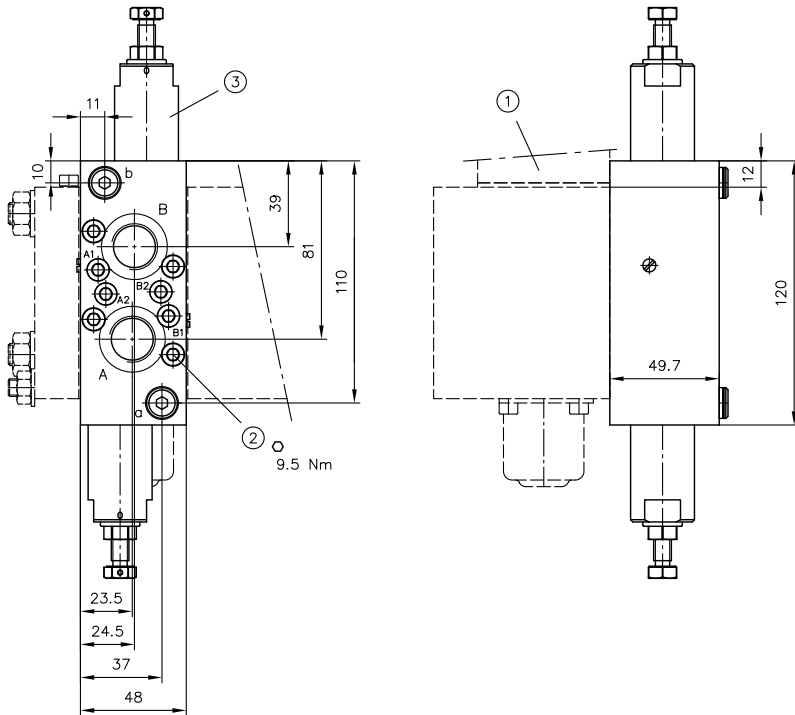
/3 DRH, /3 DRH VV
/3 DRH A, /3 DRH B
/UNF 3 DRH, /UNF 3 DRH VV



- 1 Directional valve section
- 2 Cylinder screws ISO 4762-M6x50-A2-70

Coding	Ports as per ISO 228-1 (BSPP) or SAE J 514
	A, B
/3 DRH, /3 DRH VV /3 DRH A, /3 DRH B	G 1/2
/UNF 3 DRH, /UNF 3 DRH VV	SAE-10 (7/8-14 UN-2B)

/3 AL.. BL., /3 AC.. BC, /3 ACX.. BCX..
/UNF 3 AL.. BL., /UNF 3 AC.. BC., /UNF 3 ACX.. BCX..

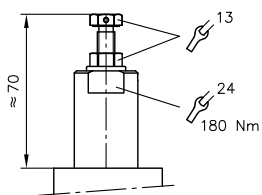


- 1 Directional valve section
- 2 Cylinder screws ISO 4762-M6x50-A2-70
- 3 Over-centre valves assembly kit

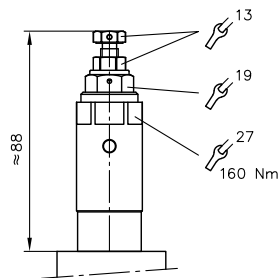
Coding	Ports as per ISO 228-1 (BSPP) or SAE J 514	
	A, B	a, b
/3 AL.. BL. /3 AC.. BC.. /3 ACX.. BCX..	G 1/2	G 1/8
/UNF 3 AL.. BL. /UNF 3 AC.. BC.. /UNF 3 ACX.. BCX..	SAE-10 (7/8-14 UN-2B)	SAE-2 (5/16-24 UNF-2B)

Load-holding valve

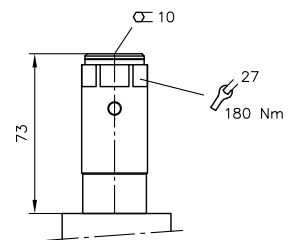
Coding L
(LHT 30)



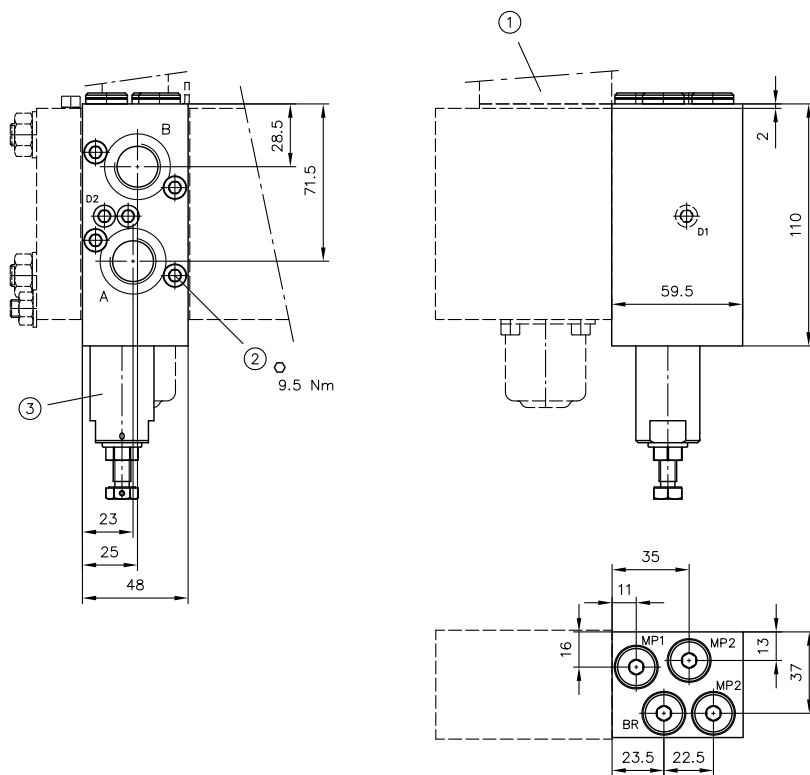
Coding C
(LHTE 30)



Coding CX
(LHTE 30X)



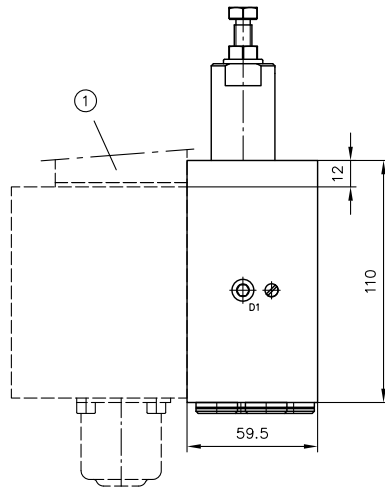
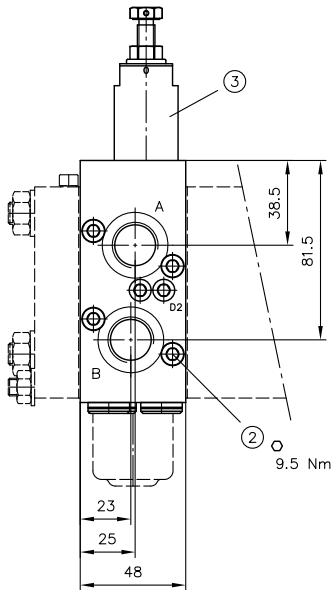
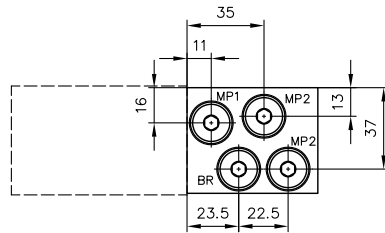
/3 AL..., /3 AC
/UNF 3 AL..., /UNF 3 AC...



- 1 Directional valve section
- 2 Cylinder screws ISO 4762-M6x60-A2-70
- 3 Over-centre valves assembly kit

Coding	Ports as per ISO 228-1 (BSPP) or SAE J 514	
	A, B	BR, MP1, MP2
/3 AL... /3 AC...	G 1/2	G 1/4
/UNF 3 AL... /UNF 3 AC...	SAE-10 (7/8-14 UN-2B)	SAE-4 (7/16-20 UNF-2B)

/3 BL..., /3 BC...
/UNF 3 BL..., /UNF 3 BC...

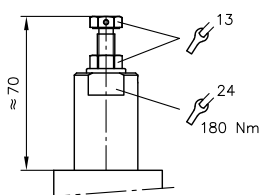


- 1 Directional valve section
- 2 Cylinder screws ISO 4762-M6x60-A2-70
- 3 Over-centre valves assembly kit

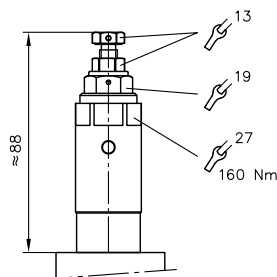
Coding	Ports as per ISO 228-1 (BSPP) or SAE J 514	
	A, B	BR, MP1, MP2
/3 BL... /3 BC...	G 1/2	G 1/4
/UNF 3 BL... /UNF 3 BC...	SAE-10 (7/8-14 UN-2B)	SAE-4 (7/16-20 UNF-2B)

Load-holding valve

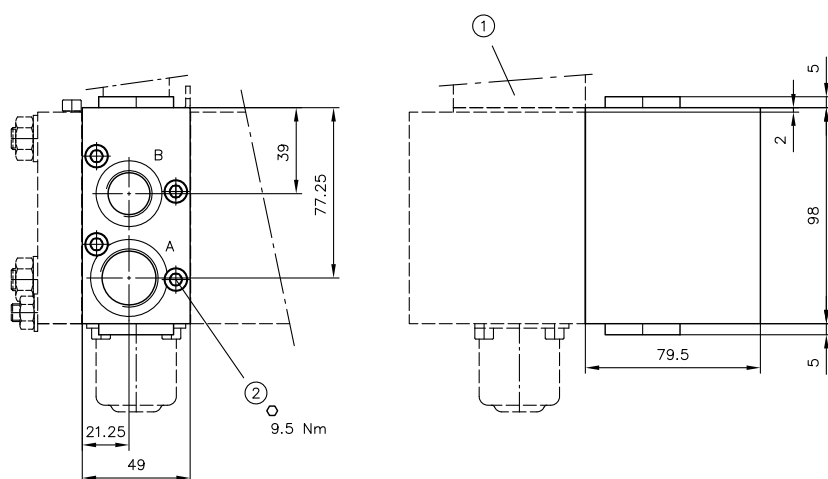
Coding L
(LHT 30)



Coding C
(LHTE 30)

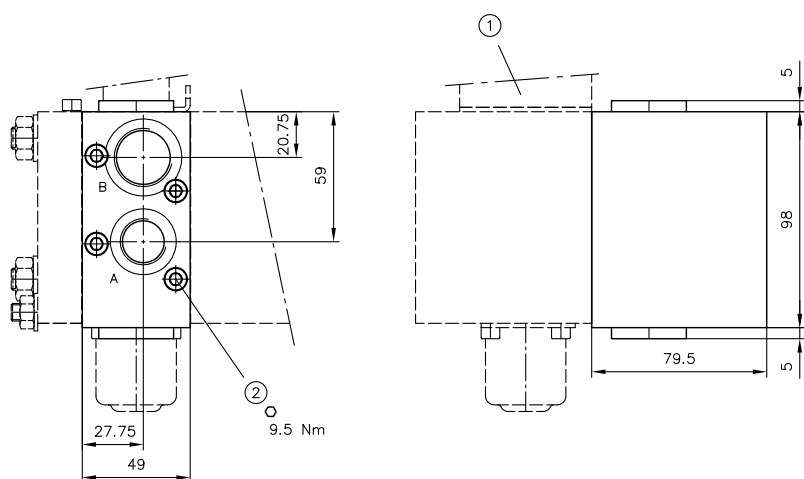


/43 DFA



- 1 Directional valve section
- 2 Cylinder screws ISO 4762-M6x80-A2-70

/43 DFB



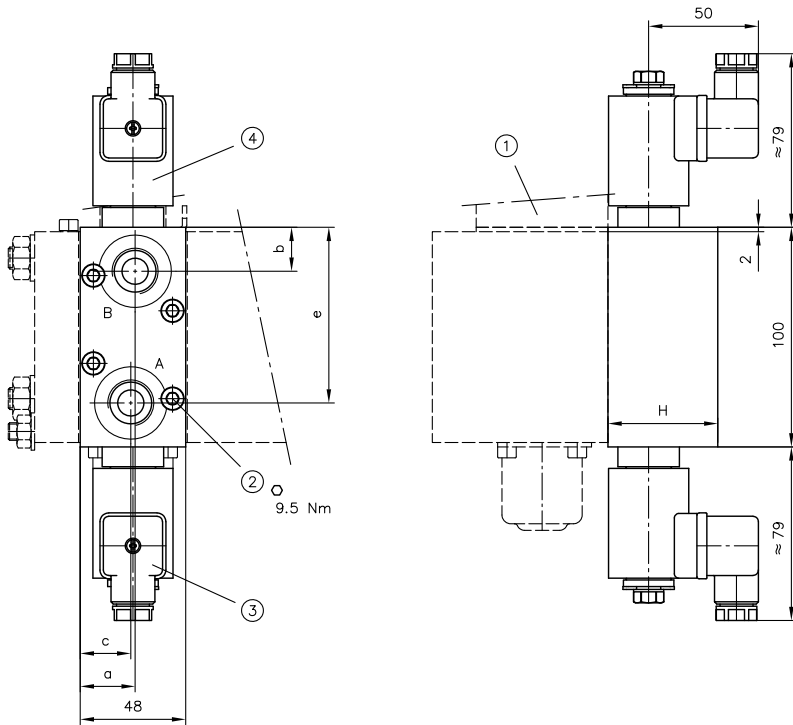
- 1 Directional valve section
- 2 Cylinder screws ISO 4762-M6x80-A2-70

Coding

Ports as per ISO 228-1 (BSPP)

	A	B
/43 DFA	G 3/4	G 1/2
/43 DFB	G 1/2	G 3/4

/3 SS, /3 SX, /3 XS
/3 VV, /3 VX, /3 XV
/UNF 3 SS, /UNF 3 SX, /UNF 3 XS
/UNF 3 VV, /UNF 3 VX, /UNF 3 XV

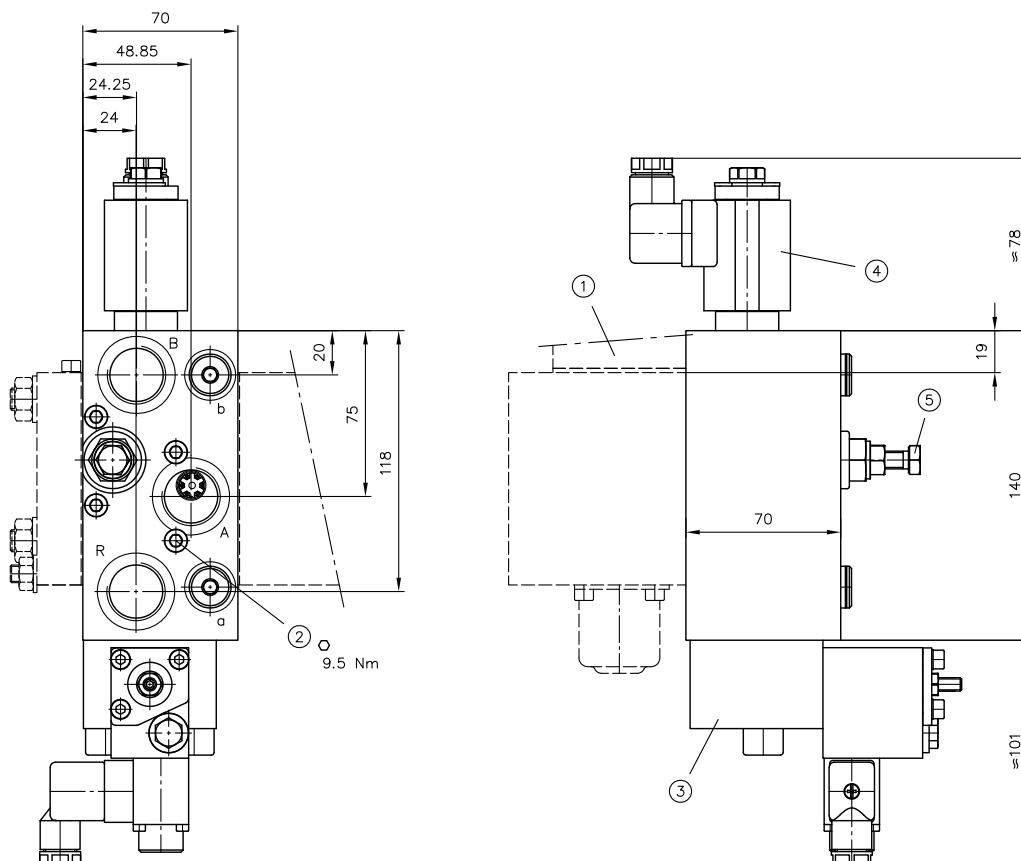


- 1 Directional valve section
- 2 Cylinder screws ISO 4762-M6x g -A2-70
- 3 Check valve type EM 32 not present on /3 XS, /3 XV, /UNF 3 XS, /UNF 3 XV
- 4 Check valve type EM 32 not present on /3 SX, /3 VX, /UNF 3 SX, /UNF 3 VX

Coding	H	a	b	c	e	g
/3 SS, /3 SX, /3 XS /3 VV, /3 VX, /3 XV	50	25	20	23	80	50
/UNF 3 SS, /UNF 3 SX, /UNF 3 XS /UNF 3 VV, /UNF 3 VX, /UNF 3 XV	55	27.25	22.25	20.75	77.75	55

Ports as per ISO 228-1 (BSPP) or SAE J 514	
A, B	
/3 SS, /3 SX, /3 XS /3 VV, /3 VX, /3 XV	G 1/2
/UNF 3 SS, /UNF 3 SX, /UNF 3 XS /UNF 3 VV, /UNF 3 VX, /UNF 3 XV	SAE-10 (7/8-14 UN-2B)

/4 BN...-EM 3...-PMVPS 8...



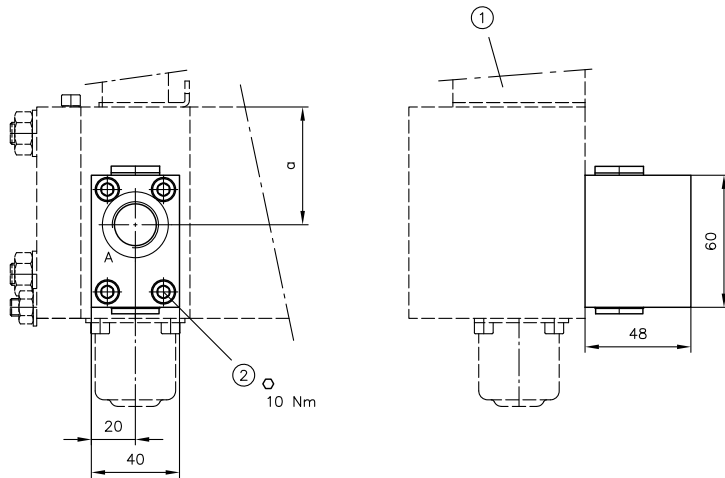
- 1 Directional valve section
- 2 Cylinder screws ISO 4762-M6x70-A2-70
- 3 Proportional pressure-limiting valve type PMVPS 8
- 4 2/2-way directional seated valve type EM. 3
- 5 Pressure setting B-side

Coding

Ports as per ISO 228-1 (BSPP)

	A, B, R	a, b
/4 BN...-EM 3...-PMVPS 8...	G 3/4	G 1/4

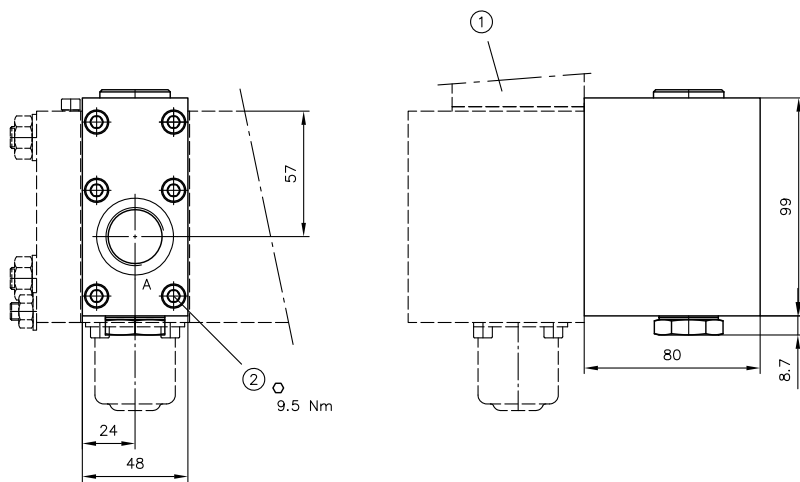
/3.. DW
/4.. DW
/UNF 3.. DW



- 1 Directional valve section
2 Cylinder screws ISO 4762-M6x45-8.8-A2-70

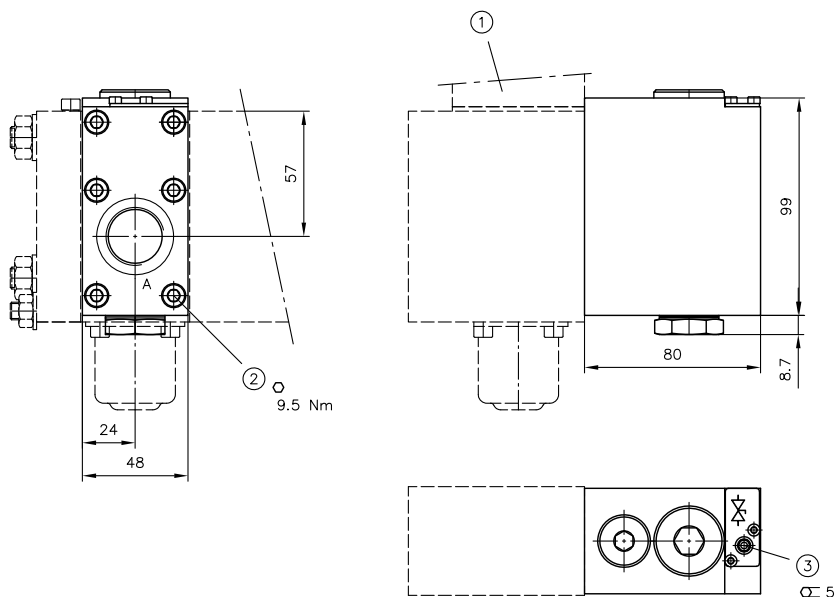
Coding	a
/3.. DW	53.5
/4.. DW /UNF 3.. DW	56.5
Ports as per ISO 228-1 (BSPP) or SAE J 514	
A	
/3.. DW	G 1/2
/4.. DW	G 3/4
/UNF 3.. DW	SAE-12 (1 1/16-12 UNF-2B)

/4.. HRP 4
/4.. HRP 4 V



- 1 Directional valve section
- 2 Cylinder screws ISO 4762-M6x80-A2-70

/4.. HRP 4
/4.. HRP 4 V



- 1 Directional valve section
- 2 Cylinder screws ISO 4762-M6x80-A2-70
- 3 Drain screw

Coding

Ports as per ISO 228-1 (BSPP)

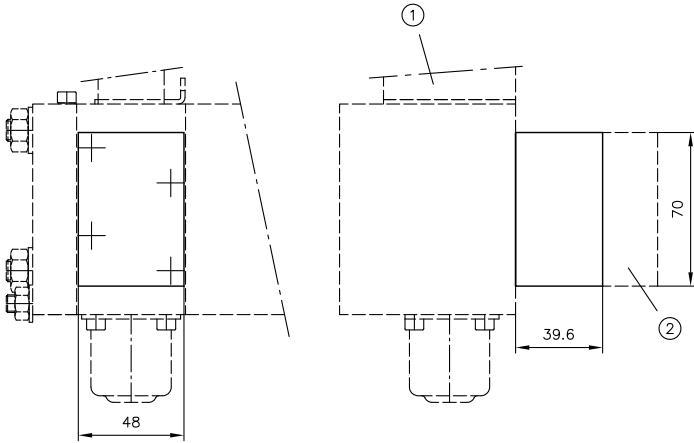
/4.. HRP 4, /4.. HRP 4 V
/4.. HRP 4, /4.. HRP 4 V

A
G 3/4

4.2.3 Intermediate plate

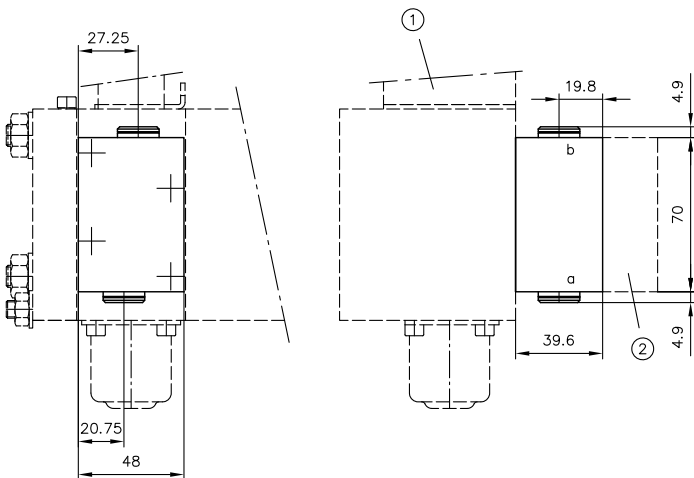
as per [Chapter 2.3.3, "Intermediate plate"](#)

/Z 40



- 1 Directional valve section
- 2 Ancillary block

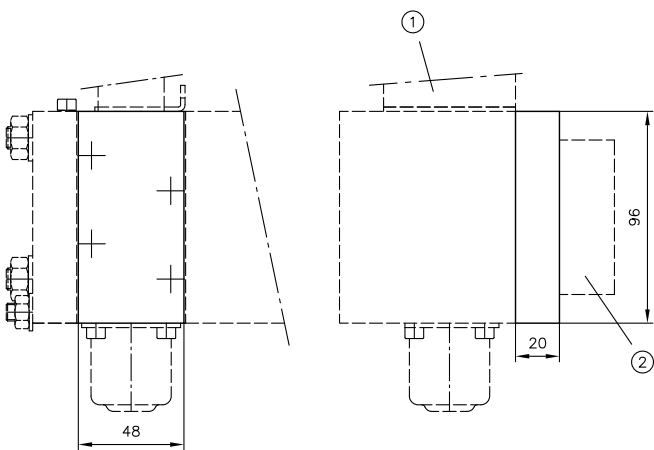
/Z 40 M
/Z 40 M UNF



- 1 Directional valve section
- 2 Ancillary block

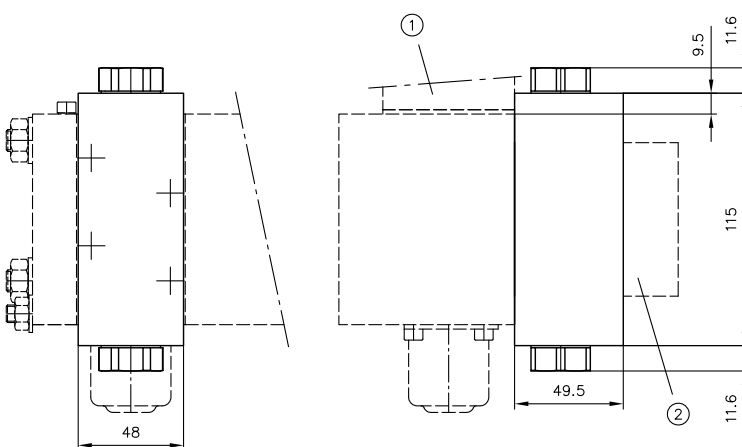
Coding	Ports as per ISO 228-1 (BSPP) or SAE J 514
	a, b
/Z 40 M	G 1/4
/Z 40 M UNF	SAE-4 (7/16-20 UNF-2B)

/Z AN BN



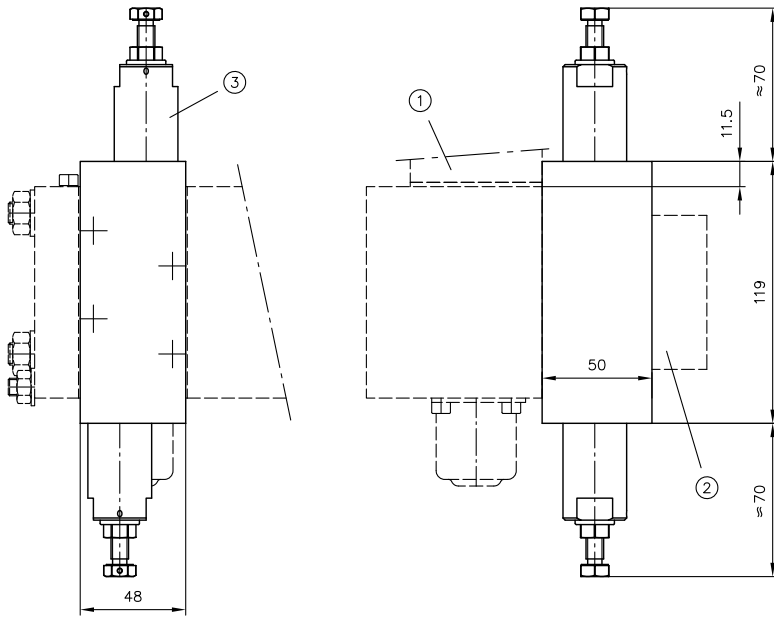
- 1 Directional valve section
- 2 Ancillary block

**/Z DRH, /Z DRH VV, /Z DRH 5 VV
/Z DRH A, /Z DRH VV A, /Z DRH 5 VV A
/Z DRH B, /Z DRH VV B, /Z DRH 5 VV B**



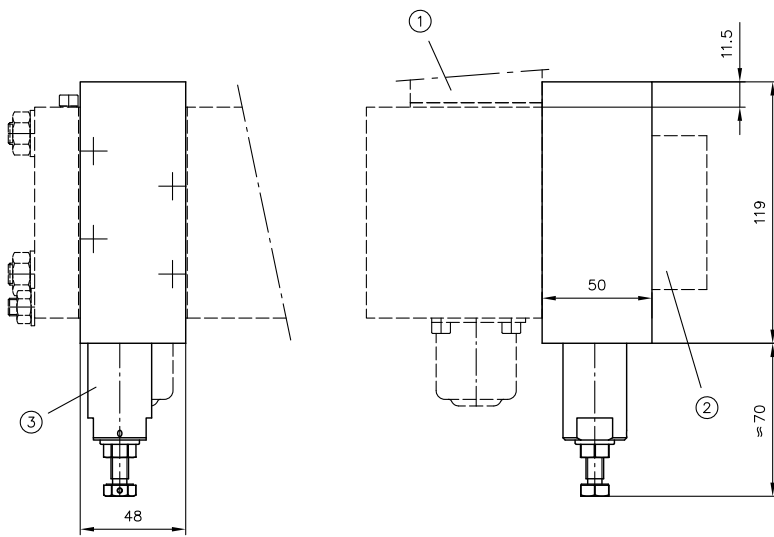
- 1 Directional valve section
- 2 Ancillary block

/Z AL... BL...



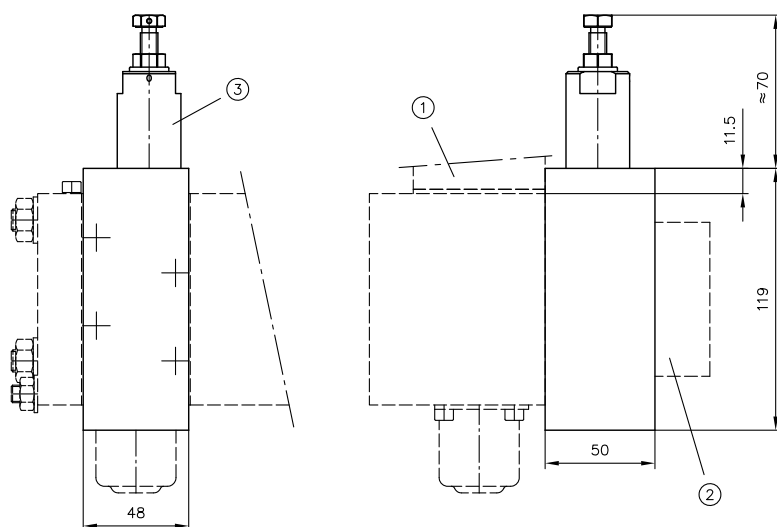
- 1 Directional valve section
- 2 Ancillary block
- 3 Load-holding valve

/Z AL...



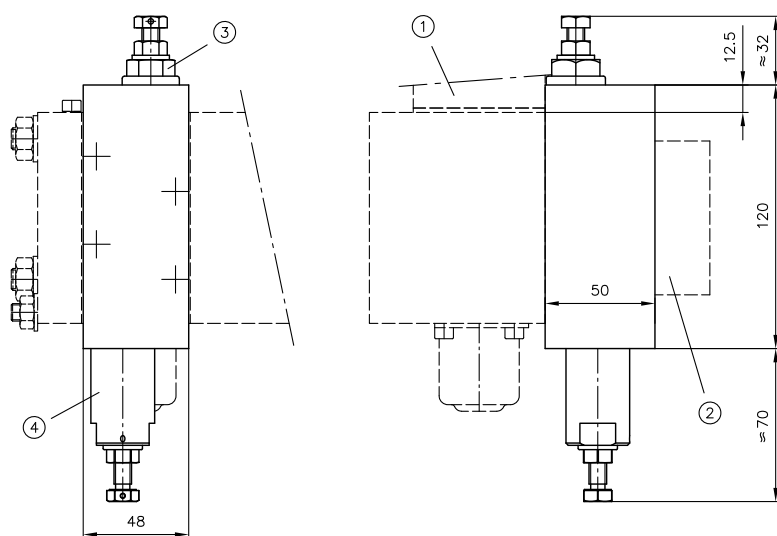
- 1 Directional valve section
- 2 Ancillary block
- 3 Load-holding valve

/Z BL...



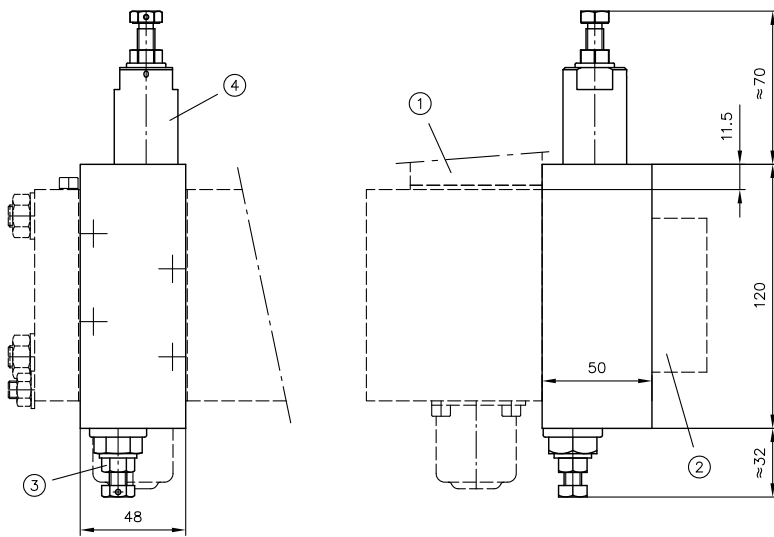
- 1 Directional valve section
- 2 Ancillary block
- 3 Load-holding valve

/Z AL... BN...



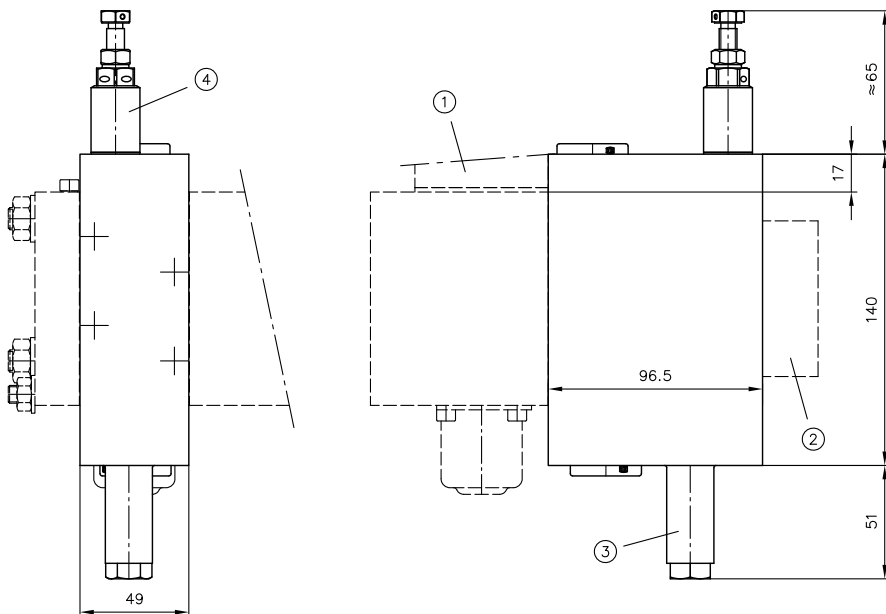
- 1 Directional valve section
- 2 Ancillary block
- 3 Pressure setting B-side
- 4 Load-holding valve

/Z BL... AN...



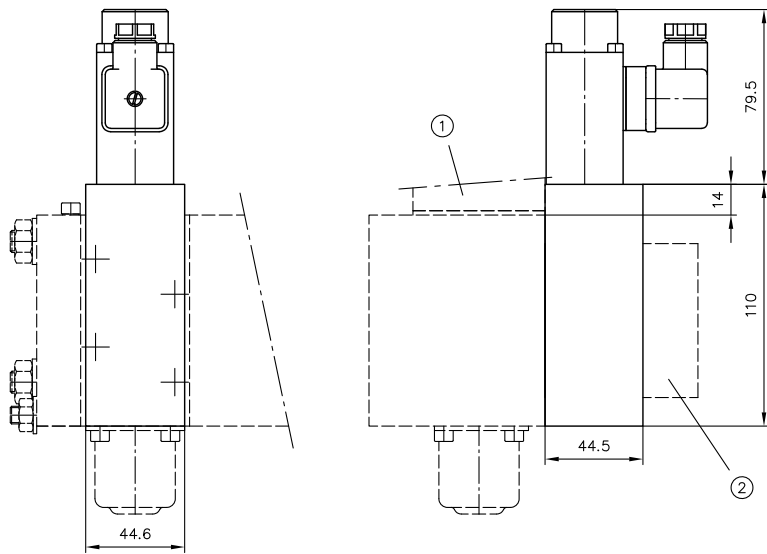
- 1 Directional valve section
- 2 Ancillary block
- 3 Pressure setting A-side
- 4 Load-holding valve

/ZN BC...



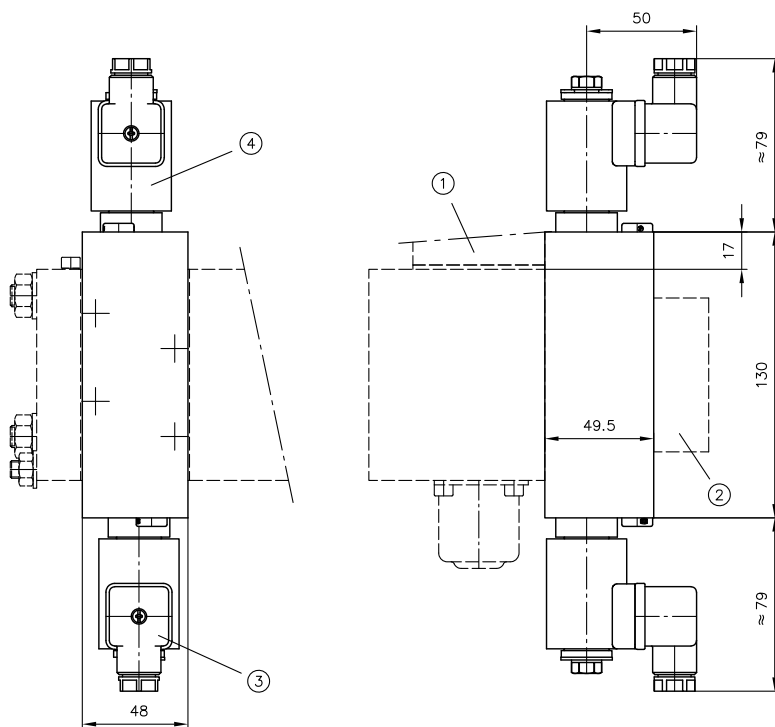
- 1 Directional valve section
- 2 Ancillary block
- 3 3-way controller
- 4 Pilot valve for 3-way controller

/ZDR
/ZDS



- 1 Directional valve section
- 2 Ancillary block

/ZSS, /ZSX, /ZXS
/ZVV, /ZVX, /ZXV

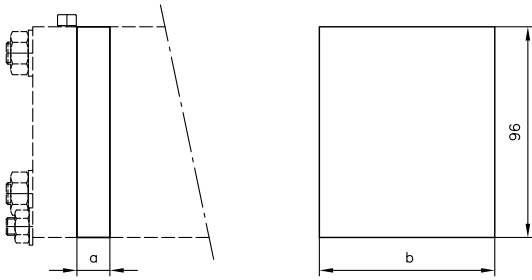


- 1 Directional valve section
- 2 Ancillary block
- 3 Check valve type EM 32 not present on /ZXS, /ZXV
- 4 Check valve type EM 32 not present on /ZSX, /ZVX

4.3 Series intermediate plate

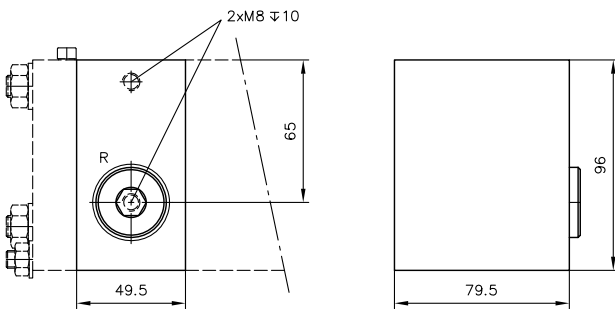
as per [Chapter 2.4, "Series intermediate plate"](#)

ZPL 33/5
ZPL 33/15
ZPL 33/15/R1
ZPL 33/15/R2
ZPL 33/22



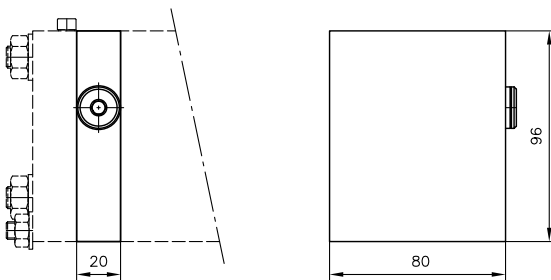
Coding	a	b
ZPL 33/5	5	79.6
ZPL 33/15	15	80
ZPL 33/15/R1	15	79.5
ZPL 33/15/R2	15	79.5
ZPL 33/22	22	79.5

ZPL 33

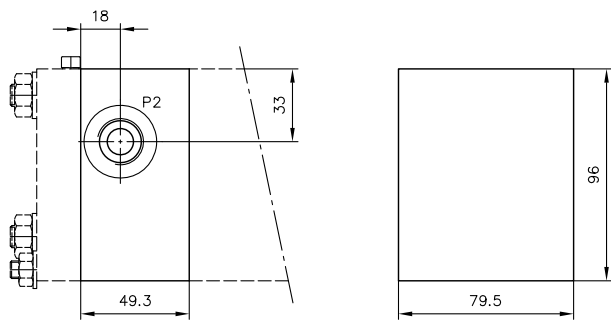


	Port as per ISO 228-1 (BSPP)
R	G 3/4

ZPL 33/20/RB R1 XTL



ZPL 3-Z3

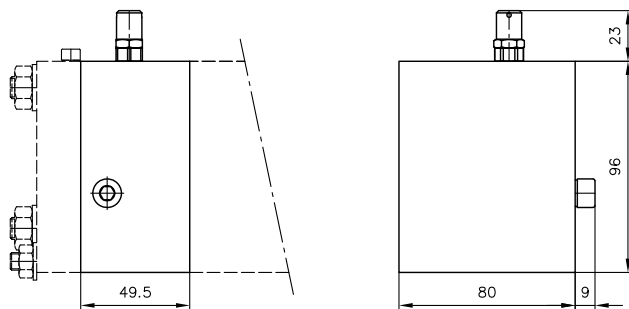


Port as per ISO 228-1 (BSPP)

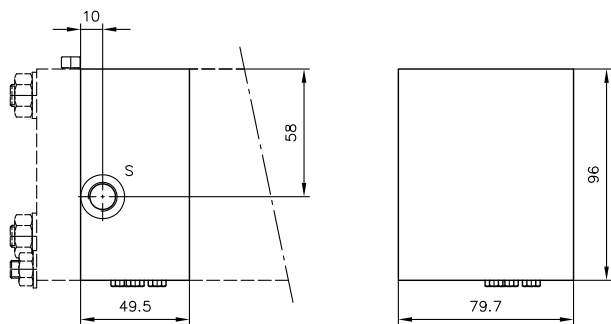
P2

G 1/2

ZPL 3 P/...



ZPL 3 S/H
ZPL 3 V/H

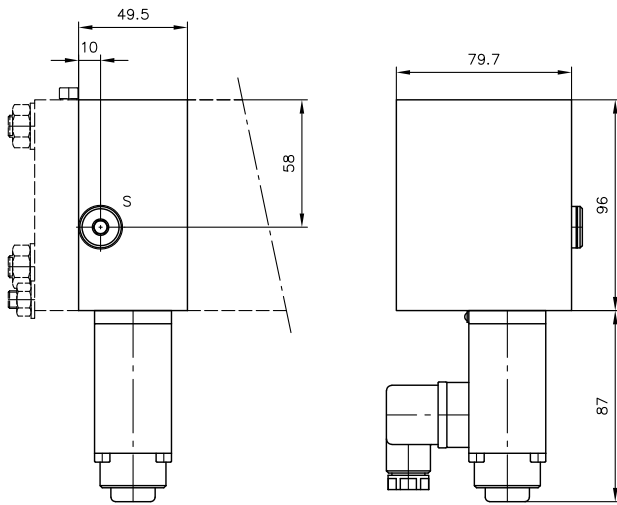


Port as per ISO 228-1 (BSPP)

S

G 1/4

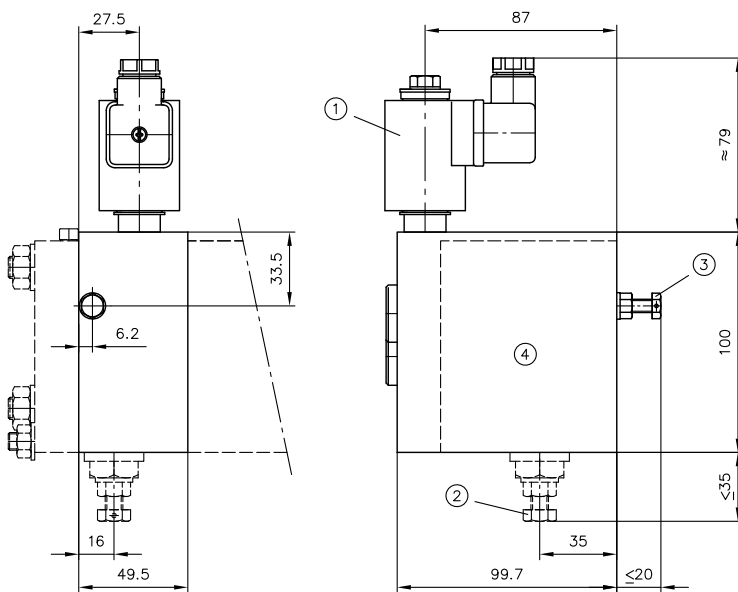
ZPL 3 S/E
ZPL 3 V/E



Port as per ISO 228-1 (BSP)

S G 1/4

ZPL 3 D, ZPL 3 DS
ZPL 3 D/..., ZPL 3 DS/...

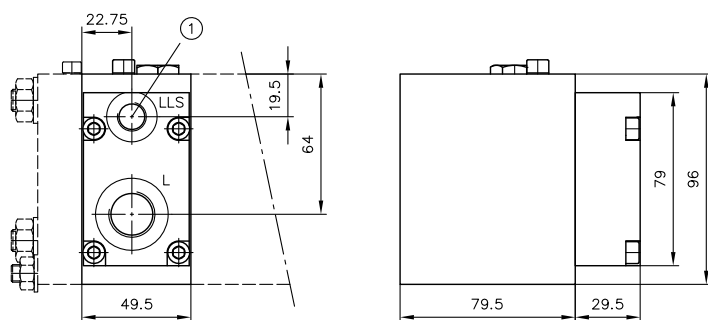


- 1 Solenoid valve type EM 21 D(S) as per [D 7490/1](#)
- 2 Setting screw size 13 for pressure-limiting valve (only for type ZPL 3 D(S)/...)
- 3 Setting screw size 10 for second speed
- 4 Directional valve section

i NOTE

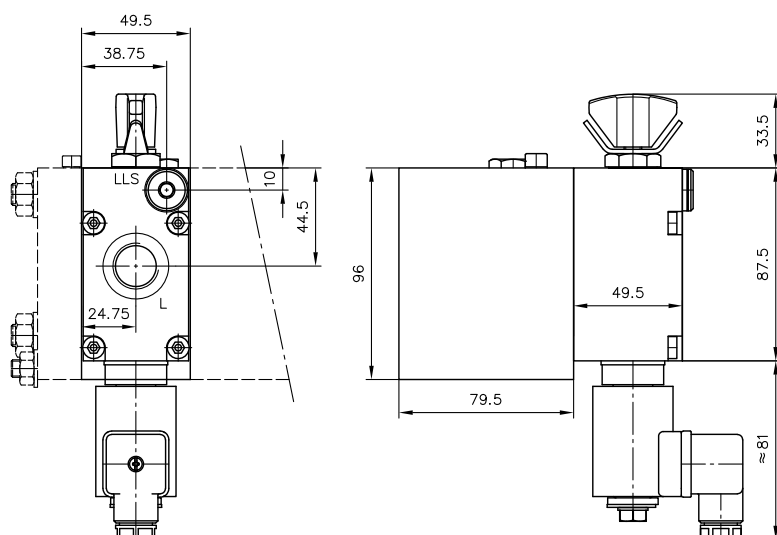
Loosen lock nut (seal lock nut) sufficiently before adjusting the throttle screw to prevent the thread from damaging the vulcanised sealing ring!

ZPL 3 VQ../3 Q
ZPL 3 VQ../UNF 3 Q



1 only open on type ZPL 3 VQ.-X/...

ZPL 3 VQ../3 QS(QV)
ZPL 3 VQ../UNF 3 QS(QV)

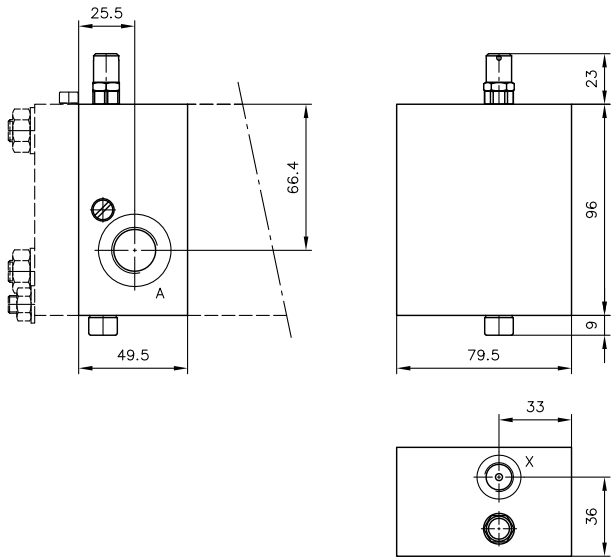


Coding

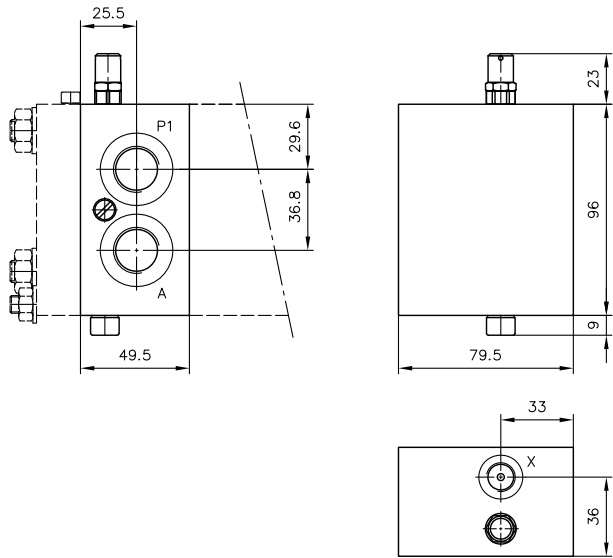
Ports as per ISO 228-1 (BSPP) or SAE J 514

	L	LLS
/3 Q..	G 1/2	G 1/4
/UNF 3 Q..	SAE-10 (7/8-14 UN-2B)	SAE-4 (7/16-20 UNF-2B)

ZPL 3 TX...



ZPL 3 TV...

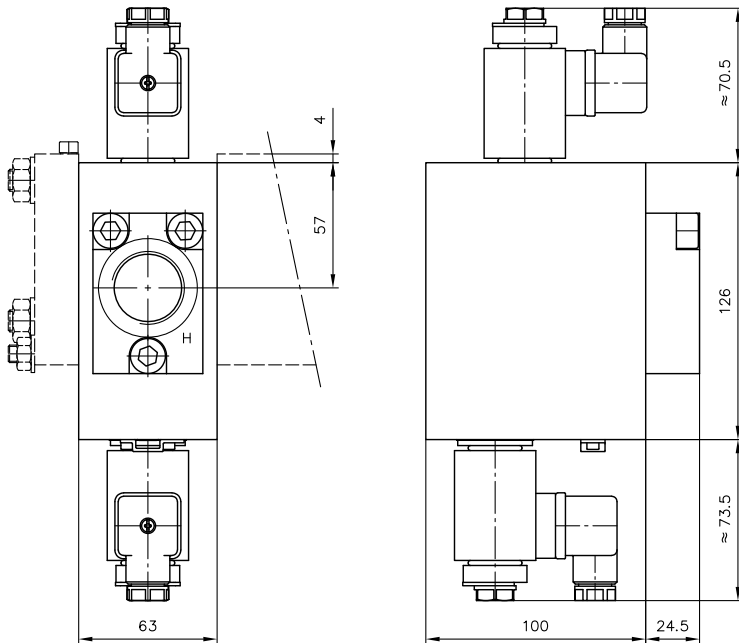


Coding

Ports as per ISO 228-1 (BSPP) or SAE J 514

	A, P1	X
ZPL 3 TX...	G 1/2	G 1/4
ZPL 3 TV...	G 1/2	G 1/4

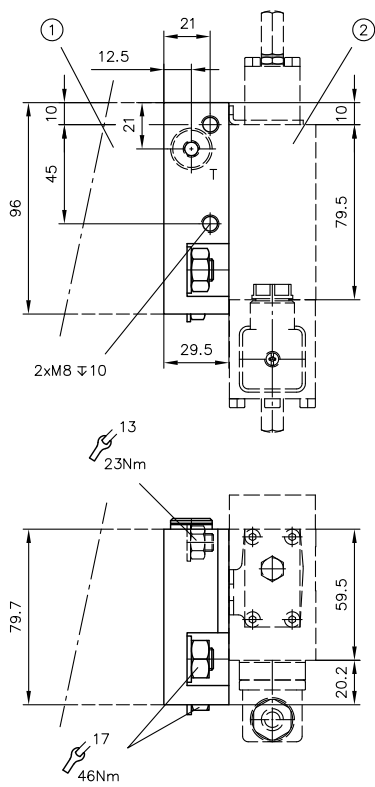
A1 RR PVPV/5



Ports as per ISO 228-1 (BSPP)

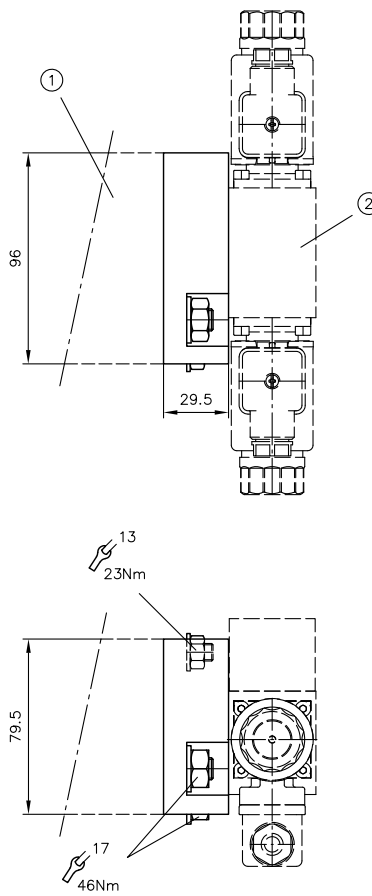
H	G 1

ZPL 32



- 1 Directional valve section PSL 3
- 2 Directional valve section PSL 2

ZPL 3-SWS 2

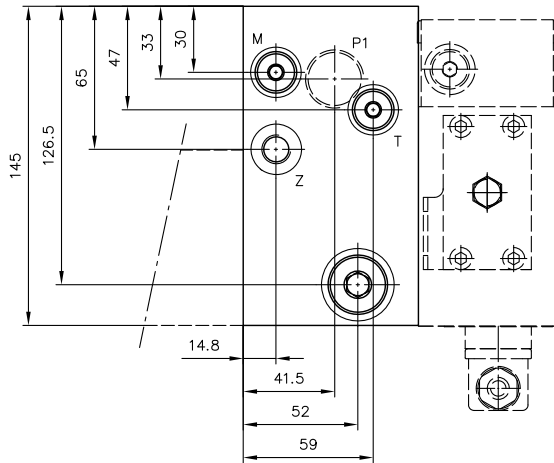
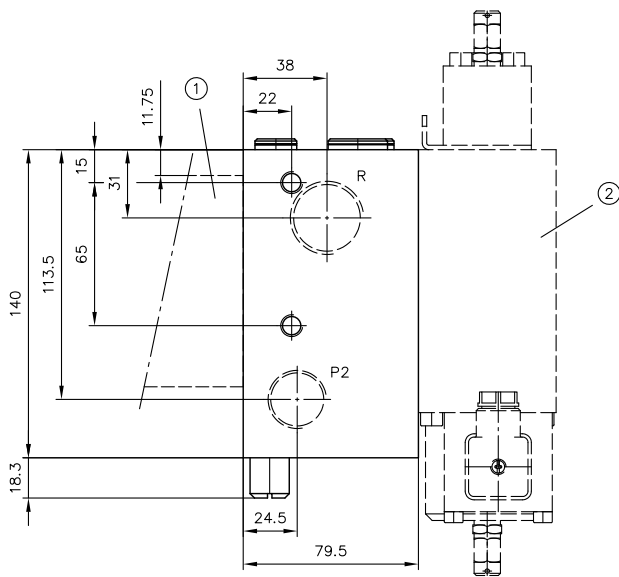


- 1 Directional valve section PSL 3
- 2 Directional valve section SWS 2

Ports as per ISO 228-1 (BSPP)

T | G 1/4

ZPL 35 P4R5 .



- 1 Directional valve section PSL 3
- 2 Directional valve section PSL 5

Ports as per ISO 228-1 (BSPP)

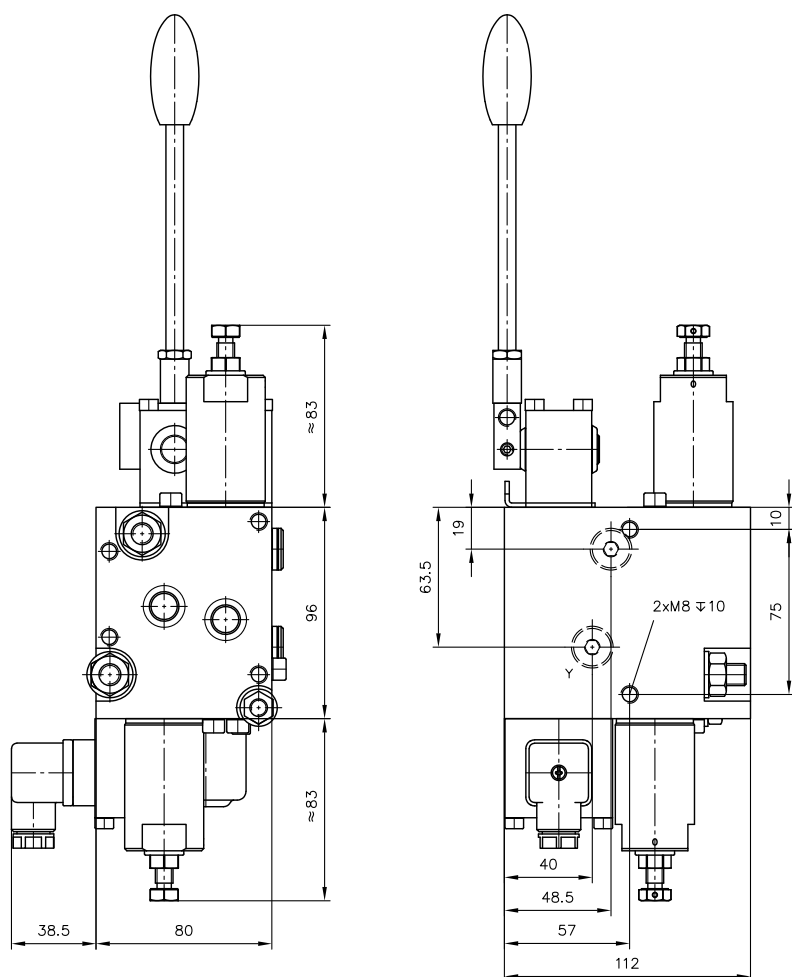
P1, P2	G 3/4
R	G 1
M, T, Z	G 1/4

4.4 Valve section with integrated load-holding valves

as per [Chapter 2.5, "Valve section with integrated load-holding valves"](#)

SL3 - F1...

SL3 - F5...

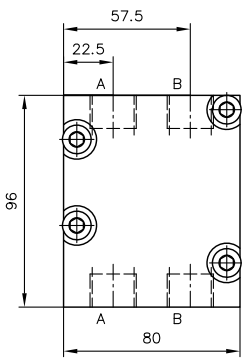


Port as per ISO 228-1 (BSPP)

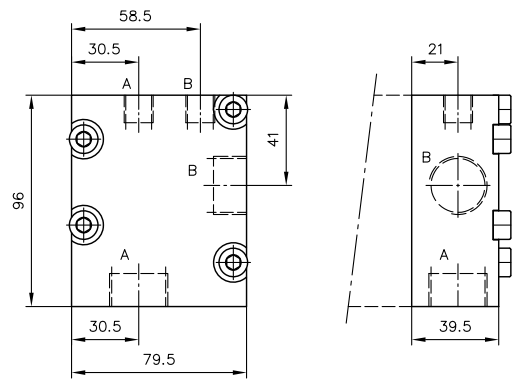
Y

G 1/4

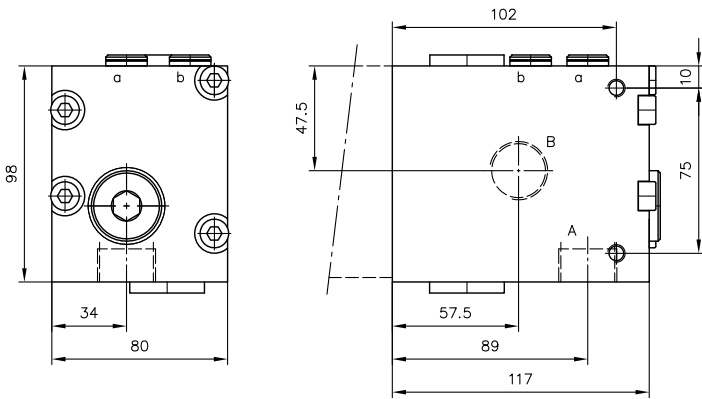
EF 30



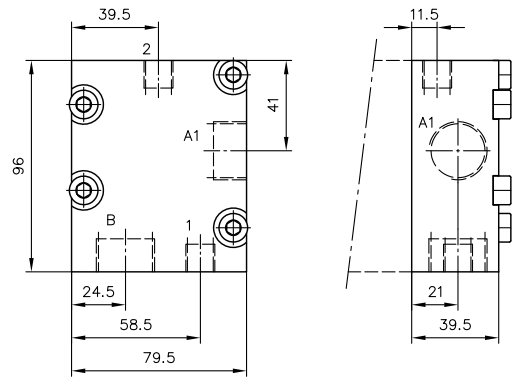
EF 41



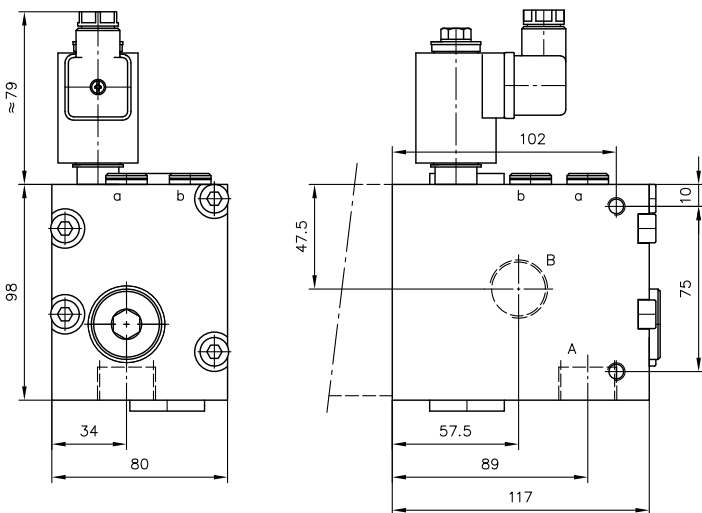
EF 31



EF 42



EF 31 D

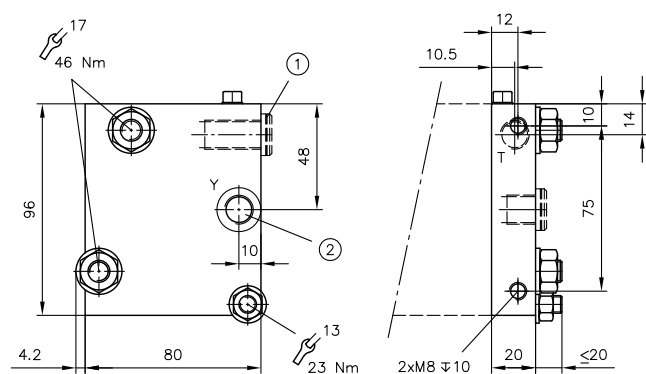


Coding	Port as per ISO 228-1 (BSPP)	
	A (A1), B	A (a, 1), B (b, 2)
EF 30	G 1/2	--
EF 31	G 3/4	G 1/4
EF 31 D	G 3/4	G 1/4
EF 41	G 3/4	G 1/4
EF 42	G 3/4	G 1/4

4.5 End plate

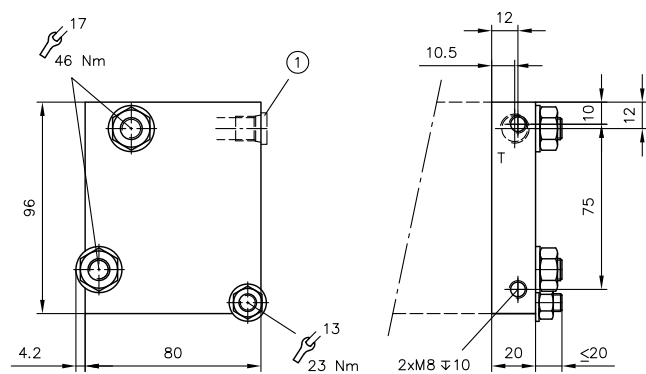
as per [Chapter 2.6, "End plate"](#)

E 1, E 2, E 4, E 5



- 1 Port T sealed on E 4 and E 5!
- 2 Port Y sealed on E 1 and E 4!

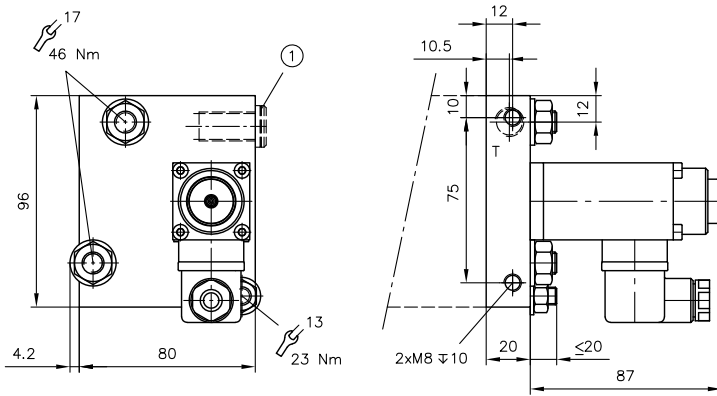
E 1 UNF, E 4 UNF



- 1 Port T sealed on E 4 UNF!

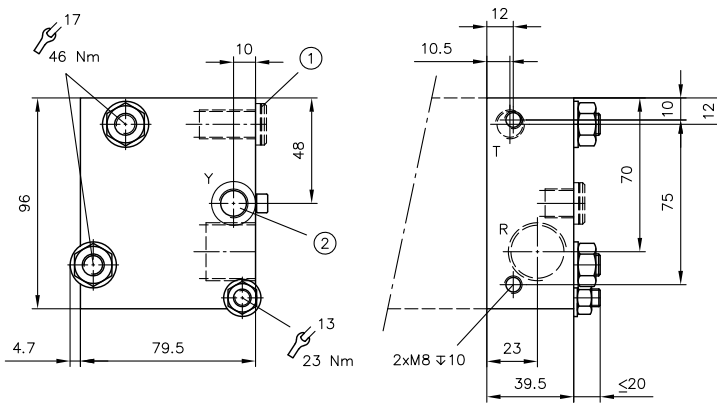
Coding	Ports as per ISO 228-1 (BSPP) or SAE J 514	
	T	Y
E 1, E 2, E 4, E 5	G 1/4	G 1/4
E 1 UNF, E 4 UNF	SAE-4 (7/16-20 UNF-2B)	--

E 3, E 6



1 Port T sealed on E 6!

E 7, E 8, E 9, E 10



1 Port T sealed on E 9 and E 10!

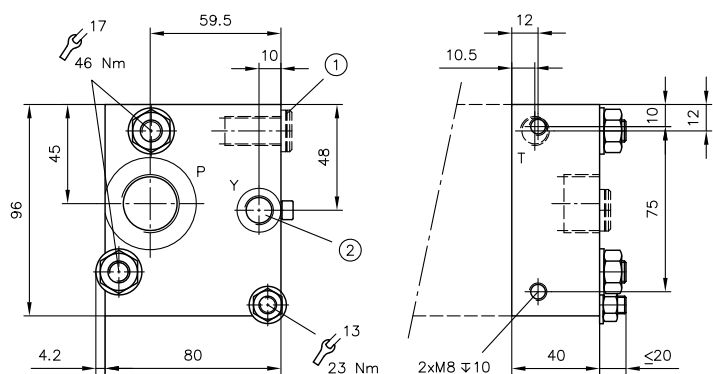
2 Port Y sealed on E 7 and E 9!

Coding

Ports as per ISO 228-1 (BSPP)

	Ports as per ISO 228-1 (BSPP)		
	T	Y	R
E 3, E 6	G 1/4	G 1/4	--
E 7, E 8, E 9, E 10	G 1/4	--	G 3/4

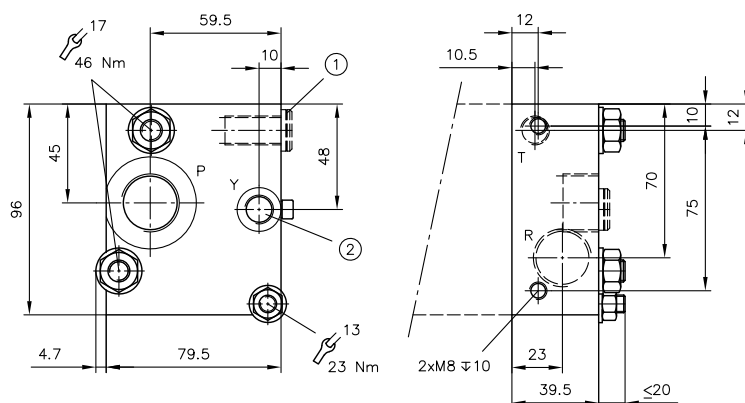
E 13, E 14, E 15, E 16



- 1 Port T sealed on E 15 and E 16!
- 2 Port Y sealed on E 13 and E 15!

E 17, E 18, E 19, E 20

E 17 UNF, E 18 UNF, E 19 UNF, E 20 UNF



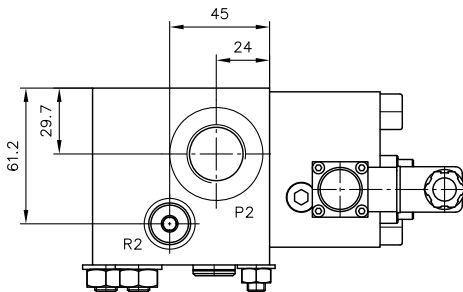
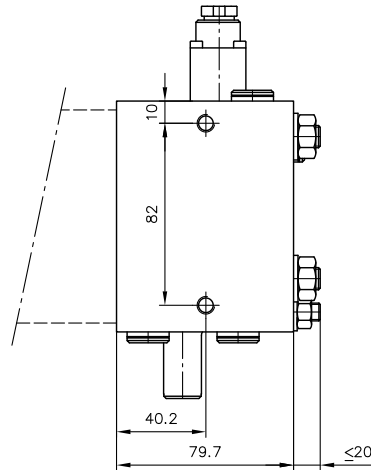
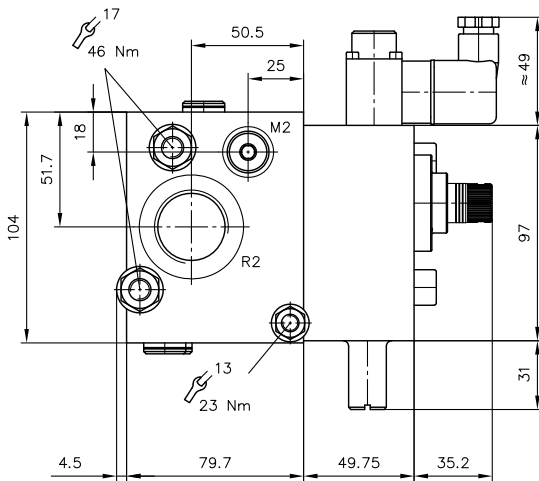
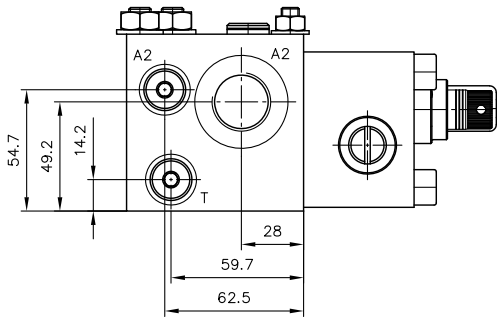
- 1 Port T sealed on E 19, E 19 UNF, E 20 and E 20 UNF!
- 2 Port Y sealed on E 17, E 17 UNF, E 19 and E 19 UNF!

Coding

Ports as per ISO 228-1 (BSPP) or SAE J 514

	T, Y	P, R
E 13, E 14, E 15, E 16 E 17, E 18, E 19, E 20	G 1/4	G 3/4
E 17 UNF, E 18 UNF, E 19 UNF, E 20 UNF	SAE-4 (7/16-20 UNF-2B)	SAE-10 (7/8-14 UNF-2B)

E 1 SEH. 3-4-...FP...
E 4 SEH. 3-4-...FP...

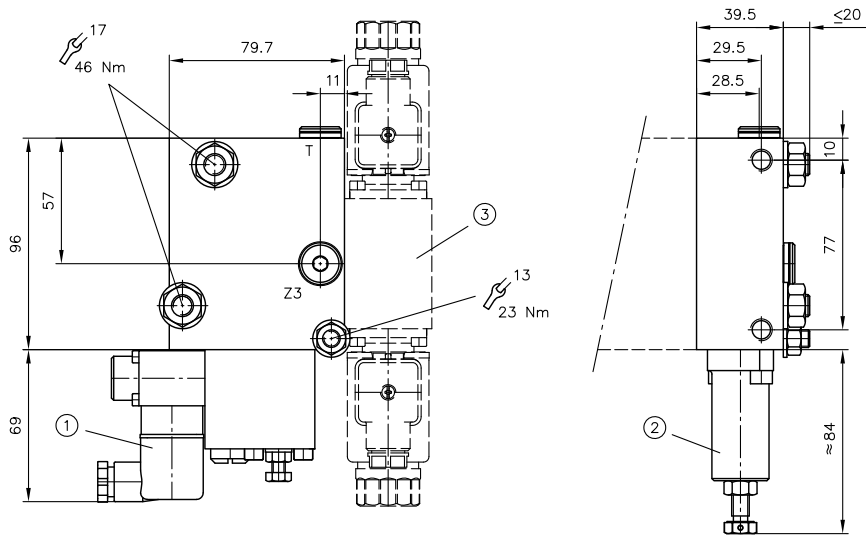


Coding

Ports as per ISO 228-1 (BSPP)

	A2, P2	R2	A2, M2, R2, T
E 1 SEH. 3-4-...FP...	G 3/4	G 1	G 1/4
E 4 SEH. 3-4-...FP...			

E 28-ADM 22 .-...
E 28-PDM 22 .-...



- 1 End plate E28-PDM 22
- 2 End plate E28-ADM 22
- 3 Directional spool valve SWS 2

Coding	Ports as per ISO 228-1	
	T, Z3	A, B
E 28-ADM 22 .-... E 28-PDM 22 .-...	G 1/4	as per D 7951

5.1 Intended use

This valve is exclusively intended for hydraulic applications (fluid engineering).

The user must observe the safety measures and warnings in this documentation.

Essential requirements for the product to function correctly and safely:

- All information in this documentation must be observed. This applies in particular to all safety measures and warnings.
- The product must only be assembled and put into operation by qualified personnel.
- The product must only be operated within the specified technical parameters. The technical parameters are described in detail in this documentation.
- All components must be suitable for the operating conditions in the event of application in an assembly.
- The operating and maintenance manual of the components, assemblies and the specific complete system must also always be observed.

If the product can no longer be operated safely:

1. Remove the product from operation and mark it accordingly.
- ✓ It is then not permitted to continue using or operating the product.

5.2 Assembly information

The product must only be installed in the complete system with standard and compliant connection components (screw fittings, hoses, pipes, fixtures etc.).

The product must be shut down correctly prior to dismantling (in particular in combination with hydraulic accumulators).



DANGER

Risk to life caused by sudden movement of the hydraulic drives when dismantled incorrectly!

Risk of serious injury or death.

- Depressurise the hydraulic system.
- Perform safety measures in preparation for maintenance.

5.2.1 Attachment

The valve bank must be mounted to the frame or base of the machine in such a way that no stress is induced. Three screws and elastic washers between the bank and the frame are recommended for mounting.

Round bearing A 2510 55WR (M8x20), manufacturer ® Co. FREUDENBERG Germany, item no. 509067

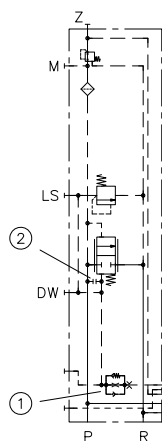
5.2.2 Piping

All fittings used must utilise deformable seals. The recommended torque values must not be exceeded.

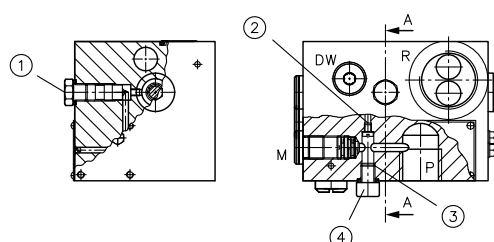
5.2.3 Converting the connection block from PSL to PSV

The PSL connection blocks PSL 45.../...-3, PSL 5.../...-3 and PSL UNF 4.../...-3 as per ["Table 3: Connection block basic type"](#) can be converted to PSV connection blocks of type PSV 45.../...-3, PSV 55.../...-3 or PSV UNF 44.../...-3 at any time. To do so, change or swap the parts listed below.

PSL 51/...-3

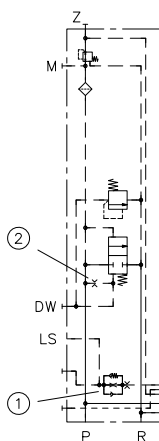


- 1 Dampening screw 7778 301
- 2 Screw 6380 013

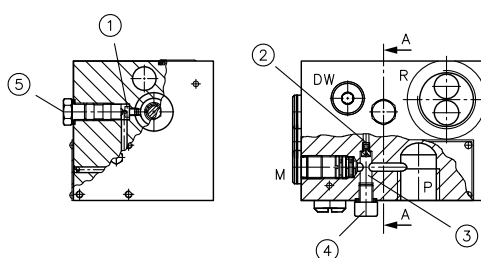


- 1 Dampening screw 7778 301
- 2 Screw 6380 013
- 3 Filter screw
- 4 Cylinder screw M8x10-A2-70 ISO 4762

PSV 55S1/...-3



- 1 Dampening screw 7778 301
- 2 Orifice M4x0.6



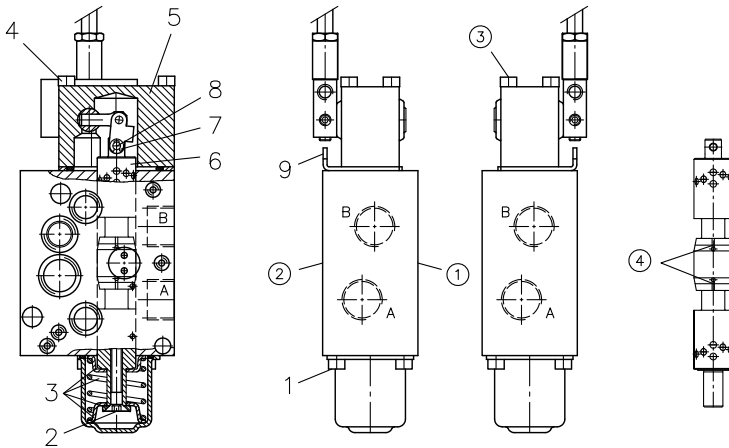
- 1 Screw 6380 013
- 2 Orifice M4x0.6
- 3 Filter screw
- 4 Cylinder screw M8x10-A2-70 ISO 4762
- 5 Dampening screw 7778 301

i NOTE

- The screw (order no. 6380 013) and carburettor orifice M4x0.6 are glued in place using liquid threadlocker. After completing the conversion, secure the parts against coming loose again.
- On the connection blocks PSL 45 U.../...-3 and PSL 5 U.../...-3, the idle circulation valve prevents conversion to a PSV-connection block.
- The reverse conversion of a PSV connection block to a PSL connection block additionally requires replacing the existing dampening screw as per ["Table 5 LS damping"](#) with an S dampening screw (7778 301).

5.2.4 Changing the valve spool

Except for valve spools type FE and JE as per ["Table 14: Circuit symbol"](#) all valve spool variants in the spool block can be swapped later.



- 1 End plate side
- 2 Connection block side
- 3 Lever housing, turned through 180°
- 4 Metering ports

Notes on swapping valve spools

1. Unscrew screws **1** (DIN EN ISO 4762-M5x8-8.8-A2K), take off spring housing
2. Unscrew screw **2** M6x40
3. Take off spring package with spring plates **3**
4. Unscrew screws **4** (DIN EN ISO 4762-M5x50-8.8-A2K)
5. Pull the lever housing out of the spool block together with the valve spool **5 6**
6. Remove lock washer DIN 6799-3.2 and pin **7 8**
7. Proceed in reverse order to reassemble with (new) valve spool

i NOTE

When assembled, the valve spool's metering ports must always face towards the end plate!

Exception: Valve spools with coding 80 do not have metering ports and can be installed any way around.

Notes on turning the lever housing through 180° (reversing switching direction)

As instructed under 1. to 7. above, but instead of installing a new valve spool, unpin the one present and reinstall after turning through 180° (see note above).

The intermediate plate **9** needs to be turned through 180° together with the lever housing.

All lever housings in the valve bank have to be turned around.

5.2.5 Seal kits

Connection block:	DS 7700-31
Valve section:	DS 7700-32
additionally for pneumatic actuation:	DS 7700-33
Intermediate plate ZPL 32:	DS 7700-22

5.3 Operating instructions

Note product configuration and pressure / flow rate

The statements and technical parameters in this documentation must be strictly observed.
The instructions for the complete technical system must also always be followed.

i NOTE

- Read the documentation carefully before usage.
- The documentation must be accessible to the operating and maintenance staff at all times.
- Keep documentation up to date after every addition or update.

⚠ CAUTION

Risk of injury on overloading components due to incorrect pressure settings!

Risk of minor injury.

- Pay attention to the maximum operating pressure of the pump and the valves.
- Always monitor the pressure gauge when setting and changing the pressure.

Purity and filtering of the hydraulic fluid

Fine contamination can significantly impair the function of the hydraulic component. Contamination can cause irreparable damage.

Examples of fine contamination include:

- Metal chips
- Rubber particles from hoses and seals
- Dirt due to assembly and maintenance
- Mechanical debris
- Chemical ageing of the hydraulic fluid

i NOTE

New hydraulic fluid from the manufacturer does not necessarily have the required level of purity.
The hydraulic fluid must be filtered during filling.

To maintain faultless operation, make sure the hydraulic fluid meets the cleanliness level.
(see also cleanliness level in [Chapter 3, "Parameters"](#))

Additionally applicable document: [D 5488/1](#) Oil recommendations

5.4 Maintenance information

Conduct a visual inspection at regular intervals, but at least once per year, to check if the hydraulic connections are damaged. If external leakages are found, shut down and repair the system.

Clean the device surface of dust deposits and dirt at regular intervals, but at least once per year.

Further information

Additional versions

- Proportional directional spool valve, type PSL and PSV size 2: D 7700-2
- Proportional directional spool valve, type PSL, PSM and PSV size 5: D 7700-5
- Proportional directional spool valve type PSLF, PSVF and SLF: D 7700-F
- Proportional directional spool valve banks type PSLF and PSVF size 7: D 7700-7F
- Actuation for proportional directional spool valves type PSL/PSV: D 7700 CAN
- Proportional directional spool valve type EDL: D 8086
- Directional spool valve banks type CWS: D 7951 CWS