

Pilot-operated, balanced-piston relief cartridges are normally closed pressure regulating valves. When the pressure at the inlet (port 1) reaches the valve setting, the valve starts to open to tank (port 2), throttling flow to regulate the pressure. These valves are accurate, have low pressure rise vs. flow, they are smooth and quiet, and are moderately fast.

**TECHNICAL DATA**

Body Type	Line mount
Interface	None
Body Features	Cross pilot
Mounting Hole Diameter	10,7 mm
Mounting Hole Depth	Through
Mounting Hole Quantity	2
Open Cavities	2
Cavity	T-17A
Port Size	1" BSPP
Model Weight	1.93 kg.

**NOTES** *Important:* Carefully consider the maximum system pressure. The pressure rating of the manifold is dependent on the manifold material, with the port type/size a secondary consideration. Manifolds constructed of aluminum are not rated for pressures higher than 3000 psi (210 bar), regardless of the port type/size specified.

**PORT DESIGNATORS**

Modifiers	Ports
YJX	All Ports: 1" BSPP;

**CONFIGURATION OPTIONS**

**Model Code Example: YJX**

**MODIFIER**

- 6061-T651 Aluminum, Buna-N
- IS 65-45-12 Ductile Iron, Buna-N, Blackened

**MANIFOLD FACES**

**FACE GRID**



Face 2

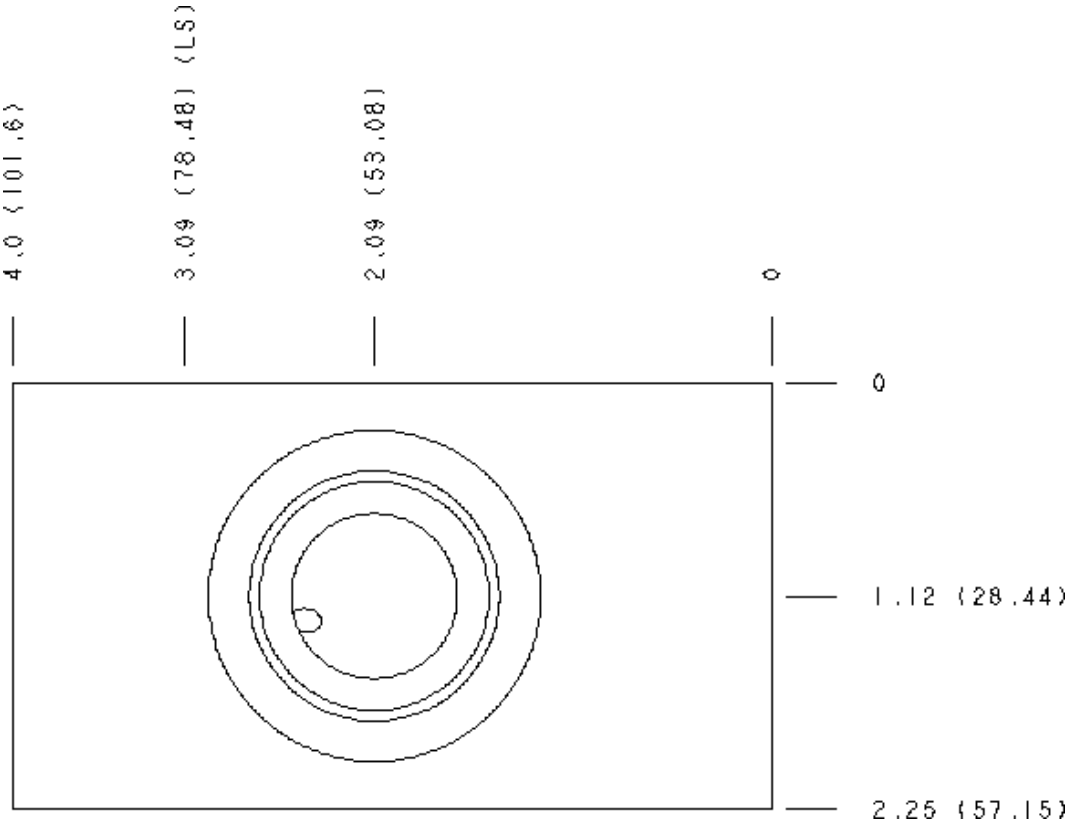

### Face 5

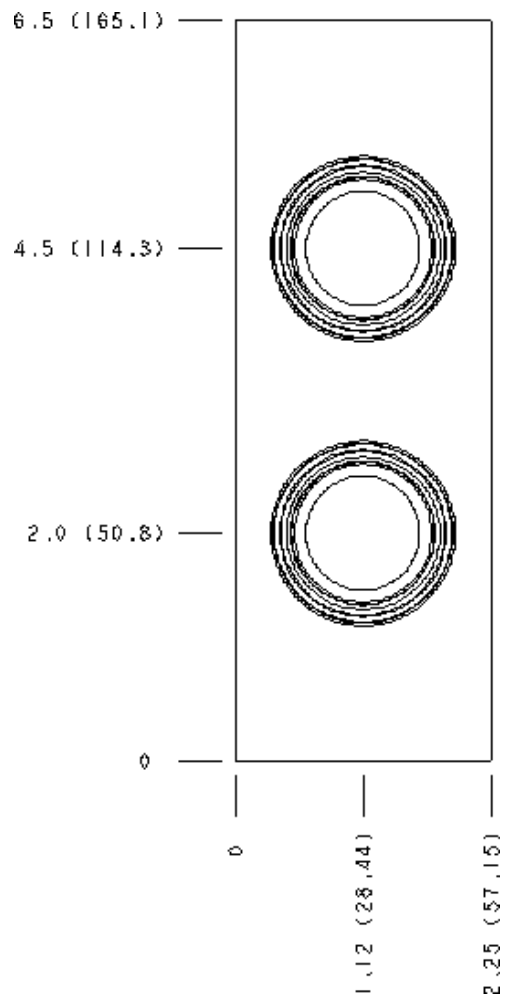

Face 6

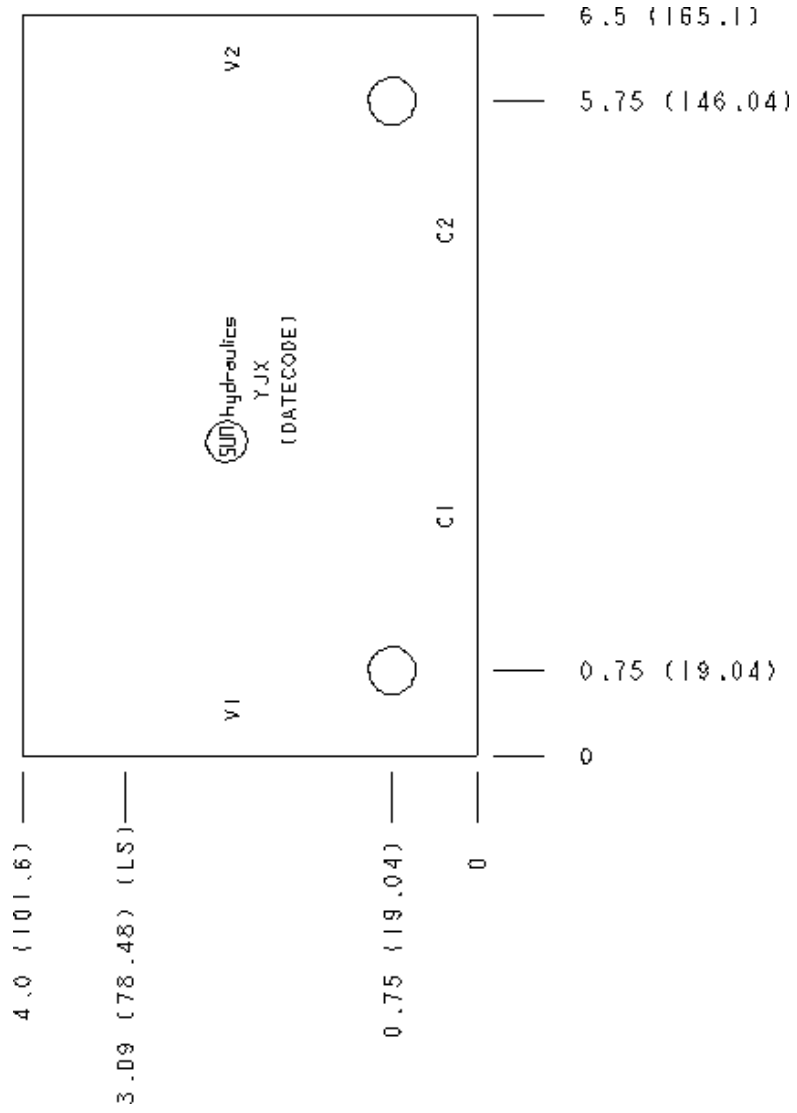

### Face 7

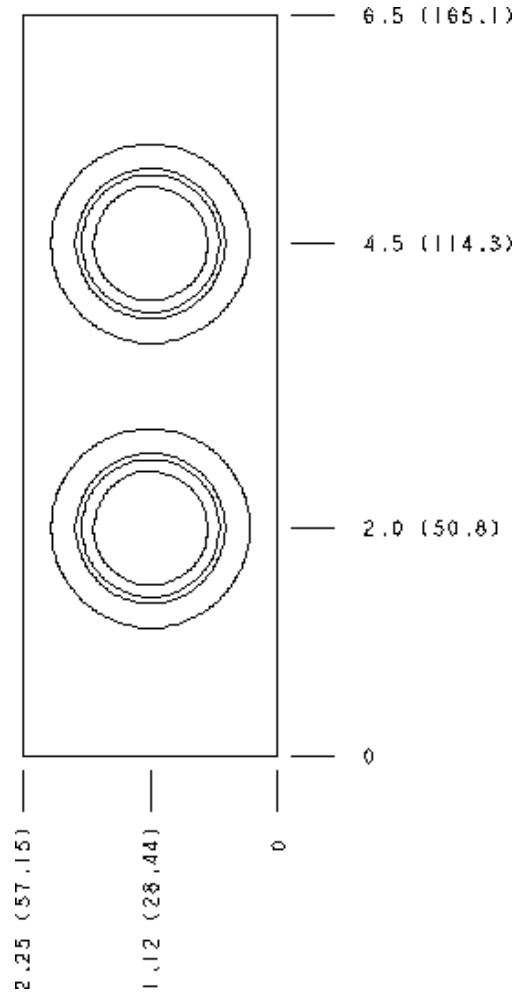

### Face 10

